



Superior Clamping and Gripping



Product Information

Anti-collision and overload protection sensor OPR

OPR

Anti-collision and overload protection sensor

Compliant. Highly responsive. Automatic reset.

Collision and overload sensor OPR

Collision and overload protection with automatic reset for protecting robots and handling units against damage resulting from collisions or overload conditions.

Field of application

Standard solution for all robot applications whereby the robot, the tool or the workpiece are to be protected against greater damages in case of a collision.



Advantages – Your benefits

Automatic reset for faster production restart after a collision

Triggering force and torque can be adjusted via the operating pressure for optimal protection of your robots and components

Integrated monitoring for signal transmission without delay in case of collisions so that the robot can be stopped immediately

ISO adapter plates as an option for easy assembly to most of robot types without any manufacturing costs/work

On option also with integrated springs for maintaining the position in the event of pressure loss

Mechanical flexibility in the event of collisions for compensation of the robot's reaction pathway in the event of a collision or overload



Sizes
Quantity: 7



Triggering force F_d
4.40 .. 14000 N



Trigger moment M_x
6 .. 2000 Nm



Trigger moment M_y
6 .. 2000 Nm



Trigger moment M_z
6.9 .. 1500 Nm

Functional description

In case of a collision, the mounting flange will be deflected. This simultaneously actuates a sensor whose signal triggers the system's emergency stop mechanism. The OPR automatically returns to zero position when the

gripper moves away from the collision object. Production can continue immediately as manual resetting is not necessary.

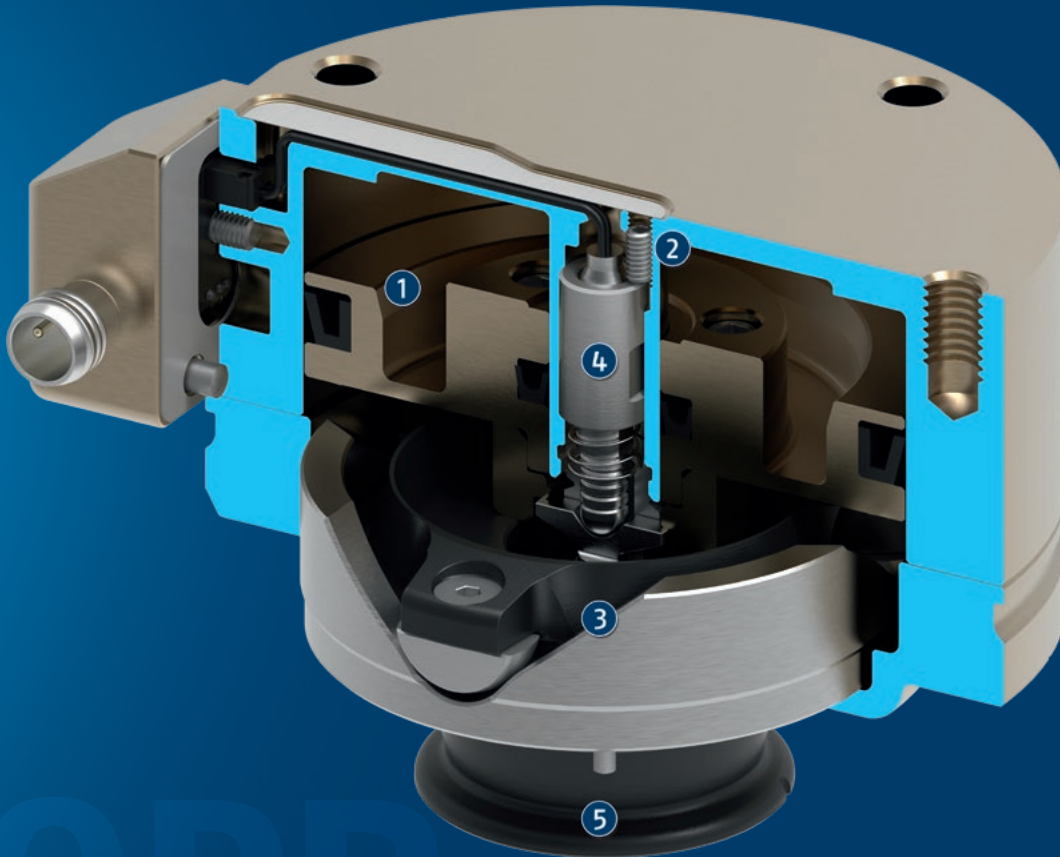

① **Pneumatic pistons**
for easy responsiveness by pressure

② **Adjustment screw**
for adjusting the switching point

③ **Bearing**
for absorption of high forces and moments

④ **Monitoring**
via mechanical switch

⑤ **Mounting flange**
deflects in the event of a collision

OPR

Anti-collision and overload protection sensor

General notes about the series

Actuation: pneumatic, with filtered compressed air as per ISO 8573-1:2010 [7:4:4].

Operating principle: integrated cylinder pistons

Splash water protection: optional

Scope of delivery: 5 m connection cable with straight connector and open wire strands

Warranty: 24 months

Harsh environmental conditions: Please note that use under harsh environmental conditions (e.g. in the coolant area, cast and grinding dust) can considerably reduce the service life of the units, and we will not take over any warranty. However, in many cases we can find a solution. Please contact us for assistance.

Application example

Triple transfer unit for packaging with small boxboards

- ① 2-finger angular gripper SWG
- ② Collision sensor OPR

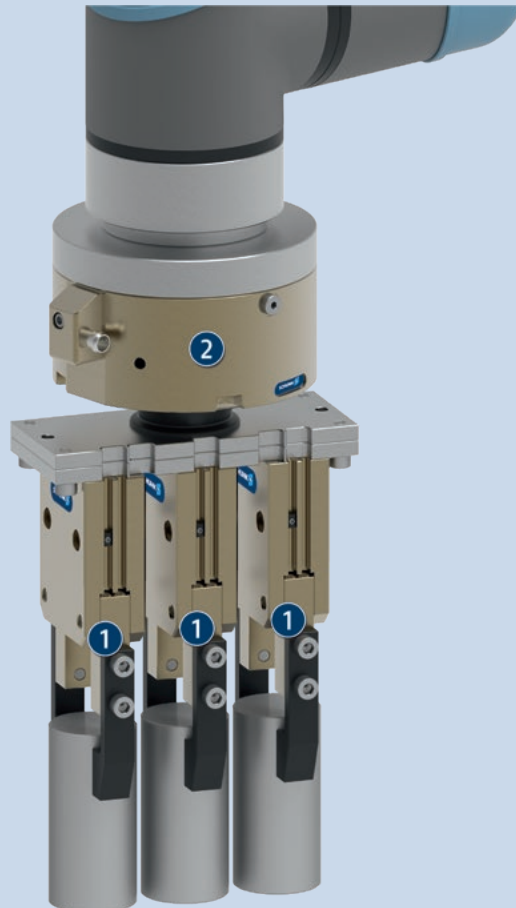

SCHUNK offers more ...

The following components make the product even more productive – the suitable addition for the highest functionality, flexibility, reliability, and controlled production.



Quick change system



Manual change system



Rotary feed-through



Universal gripper



Angular gripper



Universal gripper

① For more information on these products can be found on the following product pages or at schunk.com.

OPR 048

Anti-collision and overload protection sensor



Triggering torque Mx, My, Mz

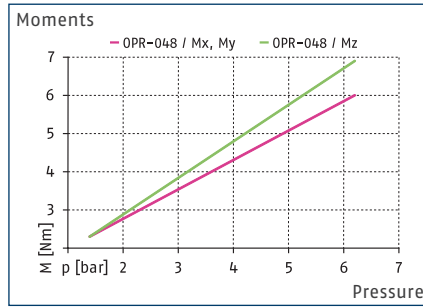

Triggering force Fd

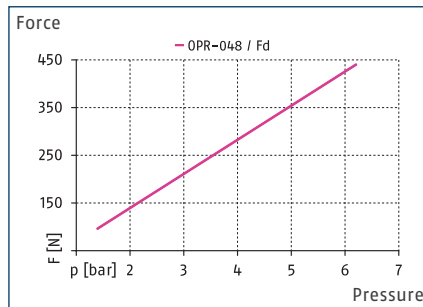

Dimensions and maximum loads

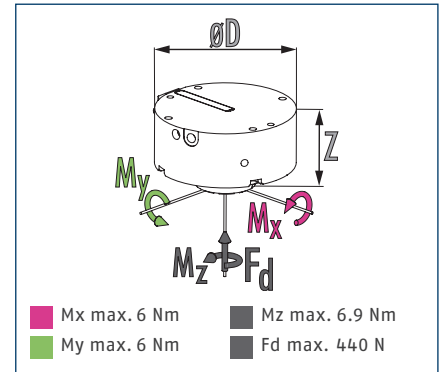

① The design of a collision sensor is defined by the occurring forces and moments in your application.

Technical data

Description		OPR-048-P00	OPR-048-P05	OPR-048-P10	OPR-048-P15
ID		0321341	0321342	0321343	0321344
Axial deflection	[mm]	5.1	5.1	5.1	5.1
Angular deflection	[°]	±13	±13	±13	±13
Deflection rotatory	[°]	±20	±20	±20	±20
Min. triggering moment, angular Mx, My	[Nm]	2.3	2.7	3.2	3.6
Min. triggering torque, rotatory Mz	[Nm]	2.3	2.7	3.1	3.5
Spring triggering force	[N]		24	48	72
Spring release torque, angular	[Nm]		0.4	0.9	1.3
Spring release torque, rotatory	[Nm]		0.4	0.8	1.2
Supply voltage	[V]	10/30	10/30	10/30	10/30
Repeat accuracy	[mm]	±0.025	±0.025	±0.025	±0.025
Responsiveness	[mm]	0.5	0.5	0.5	0.5
Repeat accuracy, rotary	[min]	5	5	5	5
Min./nom./max. operating pressure	[bar]	1.4/-/6.2	1.4/-/5.9	1.4/-/5.5	1.4/-/5.2
Weight	[kg]	0.24	0.25	0.25	0.25
Min./max. ambient temperature	[°C]	5/60	5/60	5/60	5/60
Dimensions Ø D x Z	[mm]	48 x 39	48 x 39	48 x 39	48 x 39

Main view

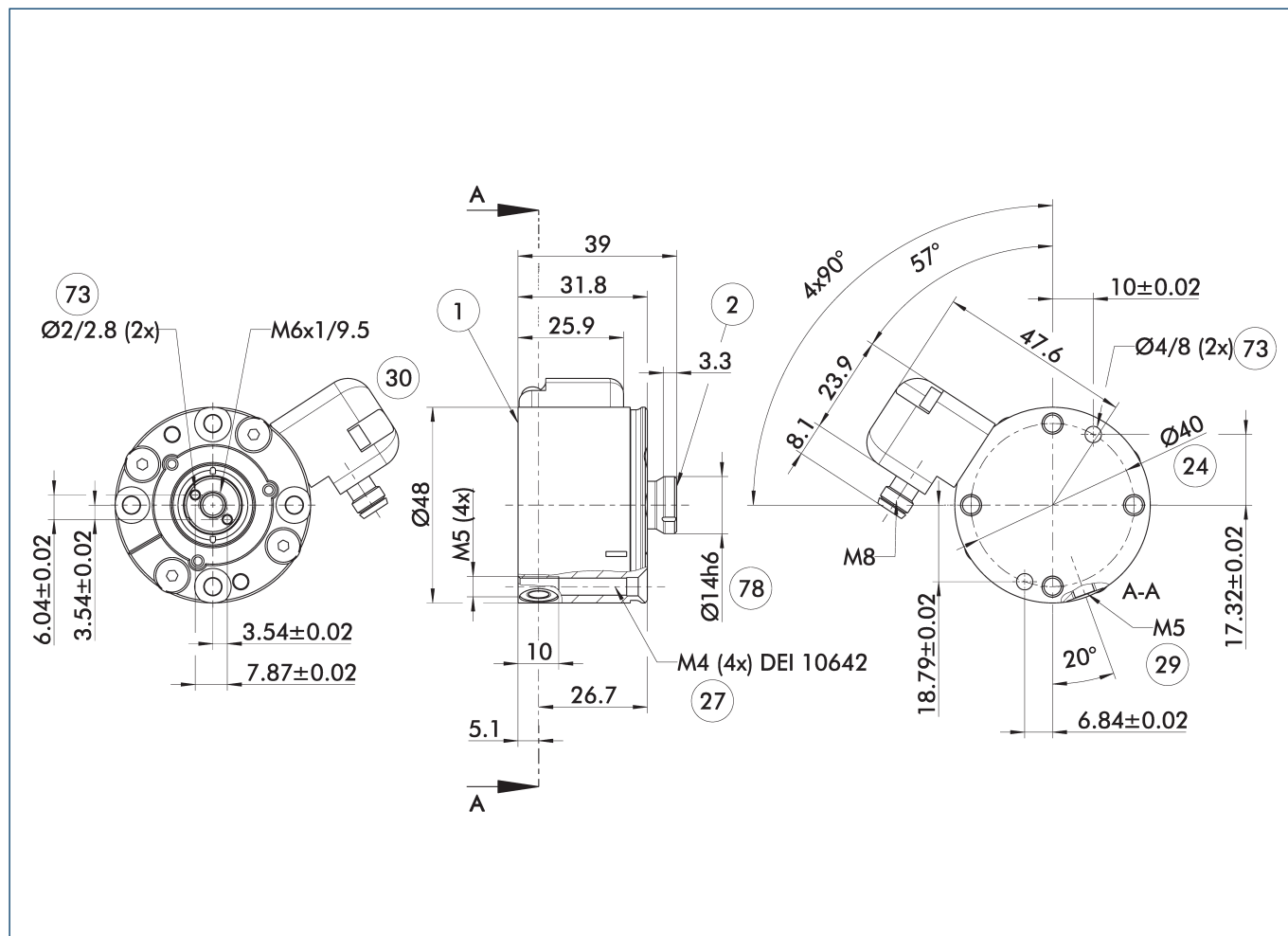

The main view shows the unit in its basic version.

- ① Robot-side connection
- ② Tool-side connection
- ④ Bolt circle
- ⑦ Through holes for screw connections
- ⑨ Air connection P
- ⑩ Cable connector in enclosed pack with 5 m connection cable
- ⑬ Fit for centering pins
- ⑭ Fit for centering

Moment loading

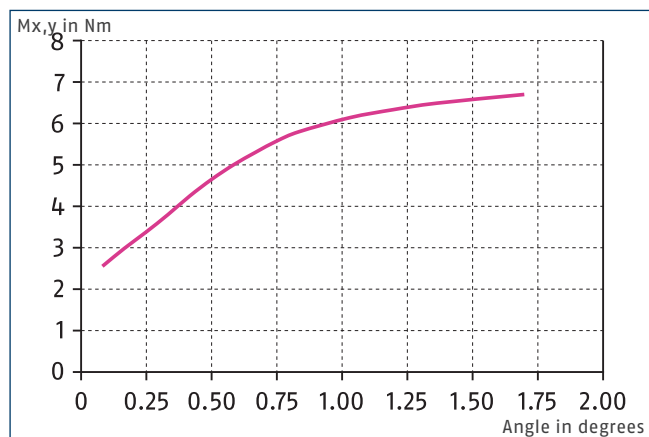

The diagram shows the angular deflection of the OPR according to the moment Mx, My with maximum permissible operating pressure.

OPR 048

Anti-collision and overload protection sensor

Adapter plate ISO 9409-A31.5-R

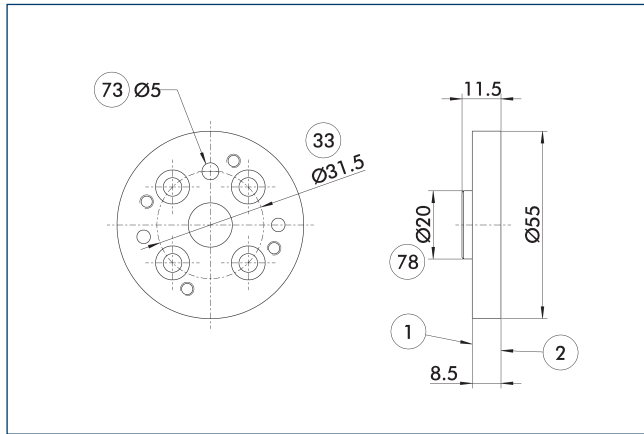

- ① Robot-side connection
- ② Tool-side connection
- ③ DIN ISO-9409 bolt circle
- ⑦③ Fit for centering pins
- ⑦⑧ Fit for centering

Robot-side adapter plate to mount the OPR to a mounting pattern according to ISO 9409-31.5-4-M5.

Description	ID
Robot side	
A-OPR-048-ISO-A31-R	0321347

Adapter plate ISO 9409-A40-R

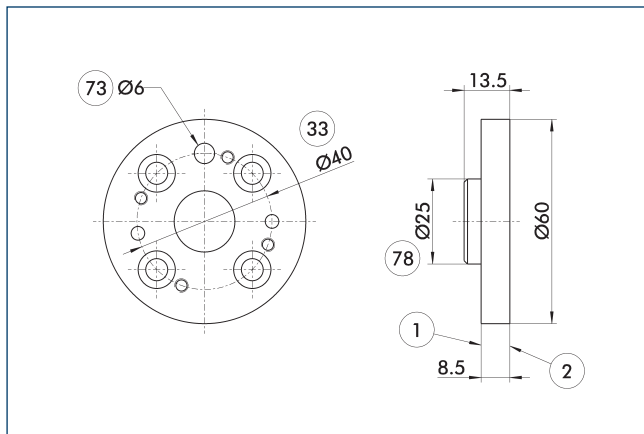

- ① Robot-side connection
- ② Tool-side connection
- ③ DIN ISO-9409 bolt circle
- ⑦③ Fit for centering pins
- ⑦⑧ Fit for centering

Robot-side adapter plate for direct attachment of the OPR to an ISO 9409-40-4-M6-compliant flange pattern.

Description	ID
Robot side	
A-OPR-048-ISO-A40-R	0321348

Adapter plate ISO-9409-A31.5-T

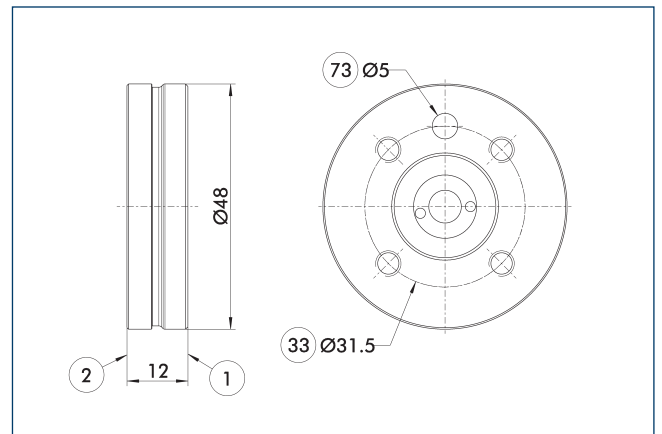

- ① Robot-side connection
- ② Tool-side connection
- ③ DIN ISO-9409 bolt circle
- ⑦③ Fit for centering pins

Tool-side adapter plate with ISO 9409 screw connection pattern.

Description	ID
Tool side	
A-OPR-048-ISO-A31-T	0321356

Adapter plate ISO 9409-A40-T

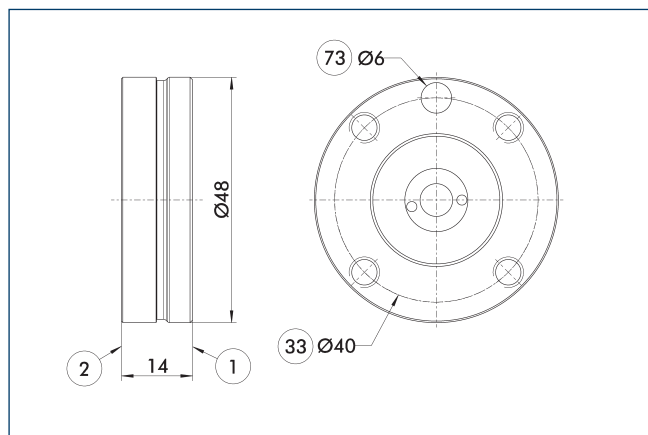

- ① Robot-side connection
- ② Tool-side connection
- ③③ DIN ISO-9409 bolt circle
- ⑦③ Fit for centering pins

Tool-side adapter plate with ISO 9409 screw connection pattern.

Description	ID
Tool side	
A-OPR-048-ISO-A40-T	0321357

Adapter plate BLANK-T

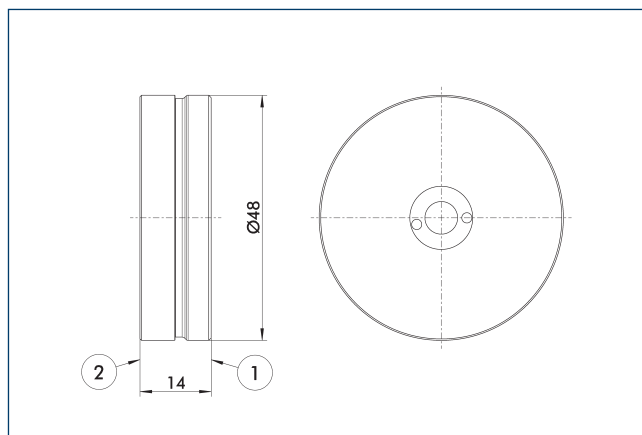

- ① Robot-side connection
- ② Tool-side connection

Unfinished tool-side adapter to be machined by the customer.

Description	ID
Tool side	
A-OPR-048-BLANK-T	0321355

Protection cover OPR-048

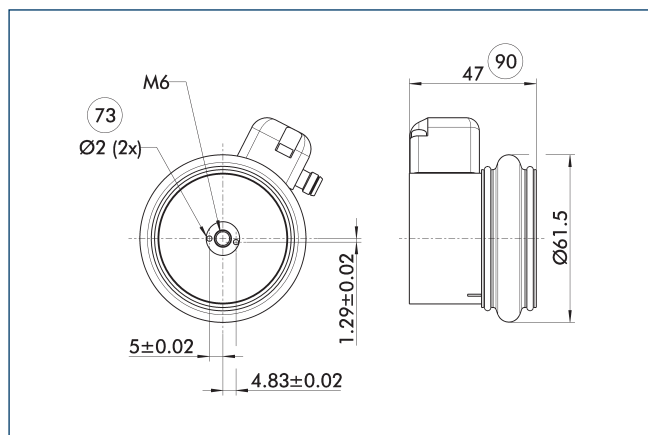

- ⑦③ Fit for centering pins
- ⑨⑩ Total height with adapter plate with flange pattern according to ISO 9409-A31.5/A40 and without flange pattern

The protection boot protects the OPR against coolants for use up to IP 65.

Description	ID	IP protection class
Protection cover		
OPR-048 Flexboot	0321351	65

- ① Please note that when using the protection boot a tool side adapter plate is also needed.

OPR 061

Anti-collision and overload protection sensor



Triggering torque Mx, My, Mz

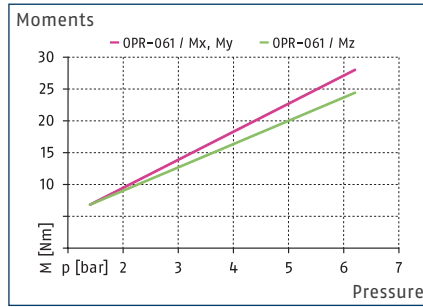

Triggering force Fd

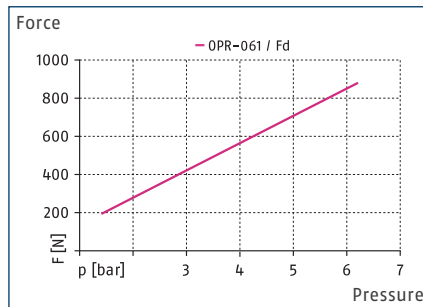

Dimensions and maximum loads

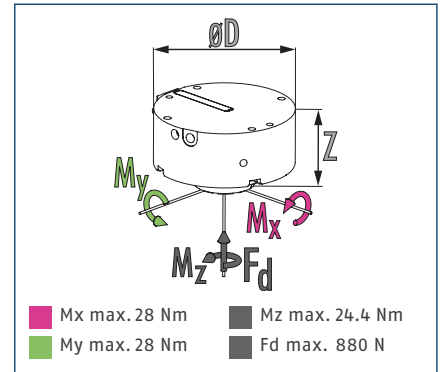

① The design of a collision sensor is defined by the occurring forces and moments in your application.

Technical data

Description		OPR-061-P00	OPR-061-P05	OPR-061-P10	OPR-061-P15
ID		0321361	0321362	0321363	0321364
Axial deflection	[mm]	5.6	5.6	5.6	5.6
Angular deflection	[°]	±11	±11	±11	±11
Deflection rotatory	[°]	±20	±20	±20	±20
Min. triggering moment, angular Mx, My	[Nm]	6.8	8.6	10.3	12.1
Min. triggering torque, rotatory Mz	[Nm]	6.8	8.5	10.1	11.8
Spring triggering force	[N]		48	96	144
Spring release torque, angular	[Nm]		1.8	3.5	5.3
Spring release torque, rotatory	[Nm]		1.7	3.3	5
Supply voltage	[V]	10/30	10/30	10/30	10/30
Repeat accuracy	[mm]	±0.025	±0.025	±0.025	±0.025
Responsiveness	[mm]	0.5	0.5	0.5	0.5
Repeat accuracy, rotary	[min]	5	5	5	5
Min./nom./max. operating pressure	[bar]	1.4/-/6.2	1.4/-/5.9	1.4/-/5.5	1.4/-/5.2
Weight	[kg]	0.32	0.33	0.33	0.33
Min./max. ambient temperature	[°C]	5/60	5/60	5/60	5/60
Dimensions Ø D x Z	[mm]	60 x 45.1	60 x 45.1	60 x 45.1	60 x 45.1
Options and their characteristics					
Splash-proof version		OPR-061-P00-S	OPR-061-P05-S	OPR-061-P10-S	OPR-061-P15-S
ID		0321365	0321366	0321367	0321368
IP protection class		65	65	65	65

Main view

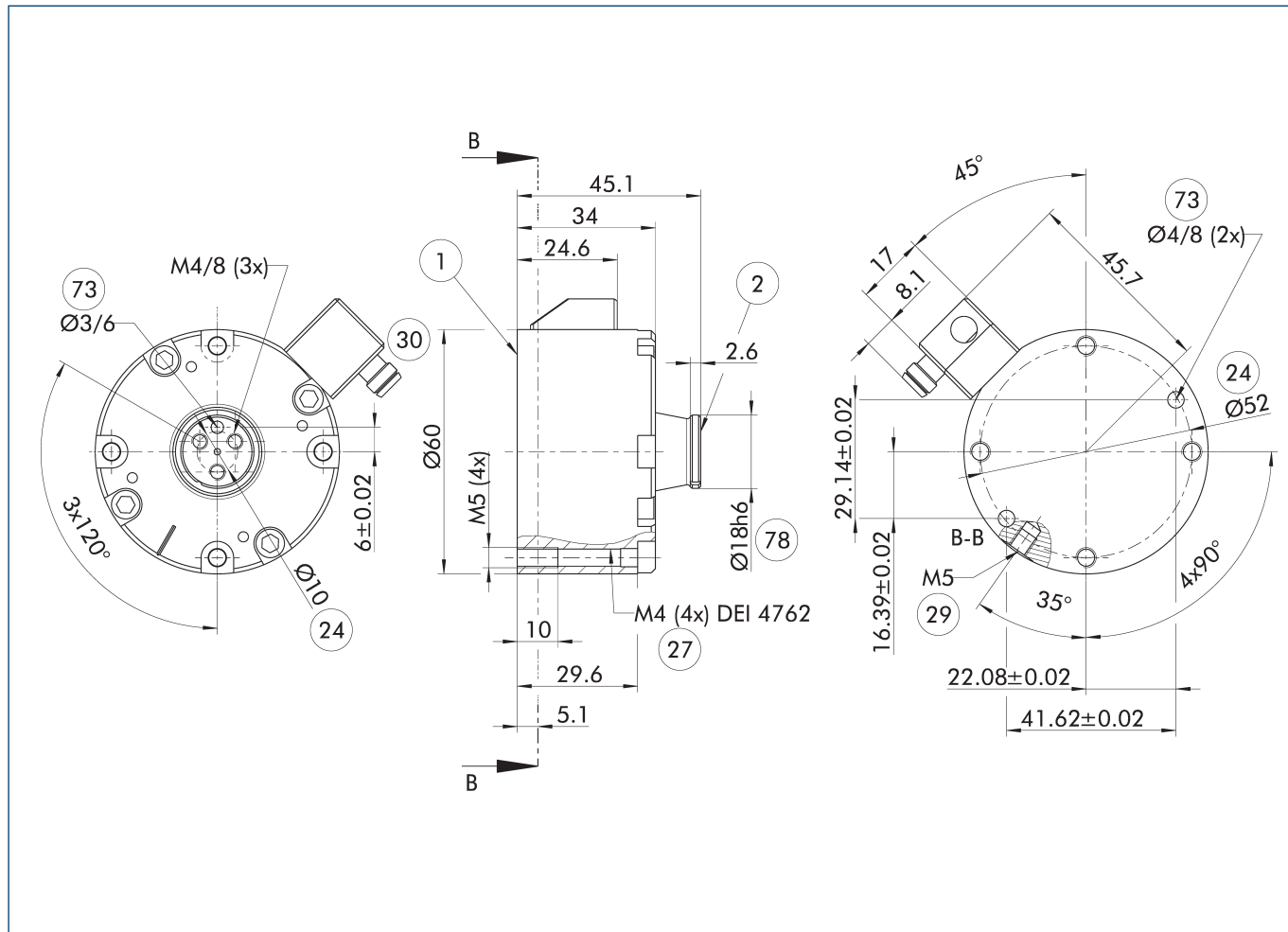

The main view shows the unit in its basic version.

- ① Robot-side connection
- ② Tool-side connection
- ②④ Bolt circle
- ②⑦ Through holes for screw connections
- ②⑨ Air connection P
- ③⑩ Cable connector in enclosed pack with 5 m connection cable
- ⑦⑩ Fit for centering pins
- ⑦⑧ Fit for centering

Moment loading

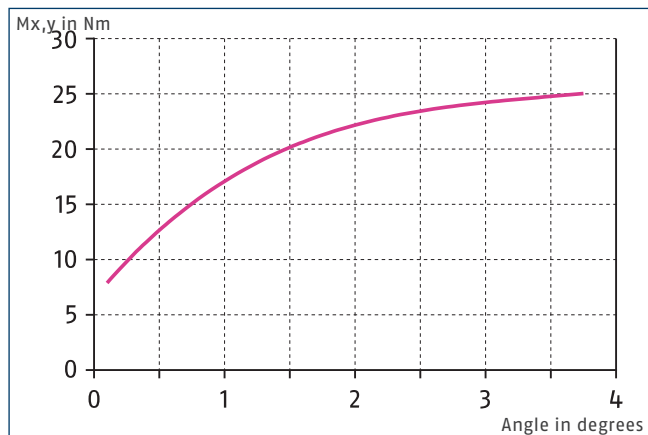

The diagram shows the angular deflection of the OPR according to the moment M_x , M_y with maximum permissible operating pressure.

Splash-proof version

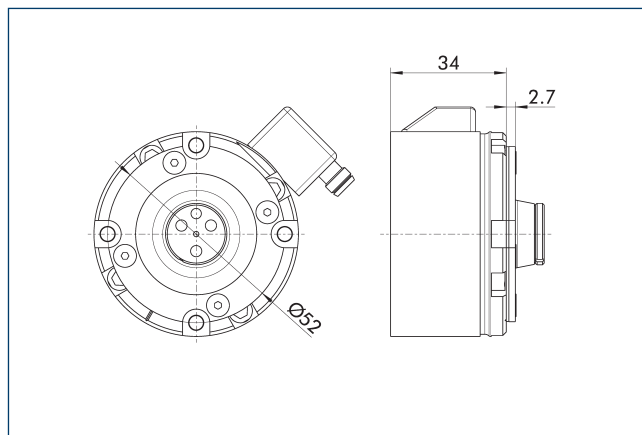

When using the splash water protection version, please be aware of the differences compared to the basic version.

OPR 061

Anti-collision and overload protection sensor

Adapter plate ISO 9409-A31.5-R

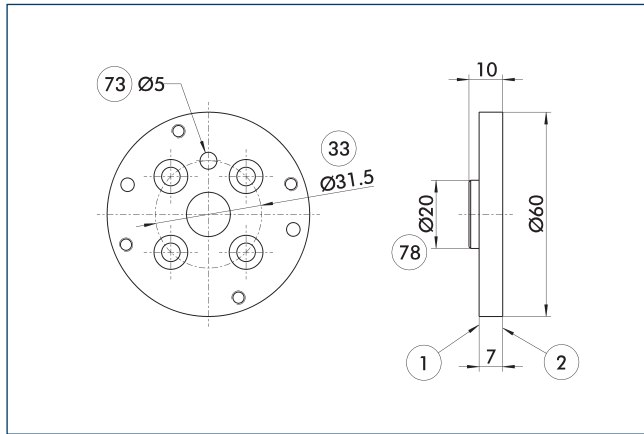

- ① Robot-side connection
- ② Tool-side connection
- ③③ DIN ISO-9409 bolt circle
- ⑦③ Fit for centering pins
- ⑦⑧ Fit for centering

Robot-side adapter plate to mount the OPR to a mounting pattern according to ISO 9409-31.5-4-M5.

Description	ID	
Robot side		
A-OPR-061-ISO-A31-R	0321369	

Adapter plate ISO 9409-A40-R

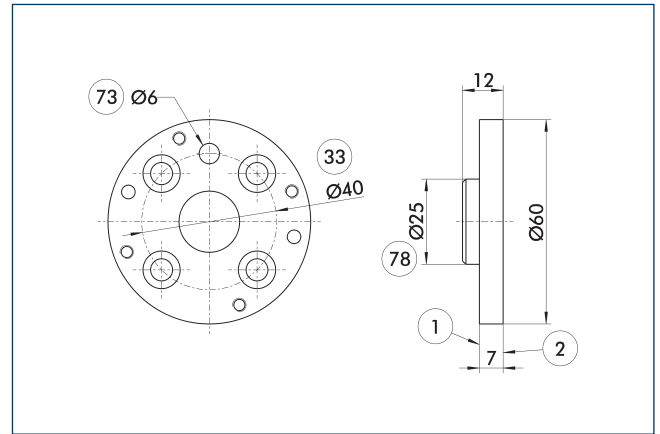

- ① Robot-side connection
- ② Tool-side connection
- ③③ DIN ISO-9409 bolt circle
- ⑦③ Fit for centering pins
- ⑦⑧ Fit for centering

Robot-side adapter plate for direct attachment of the OPR to an ISO 9409-40-4-M6-compliant flange pattern.

Description	ID	
Robot side		
A-OPR-061-ISO-A40-R	0321370	

Adapter plate ISO 9409-A50-R

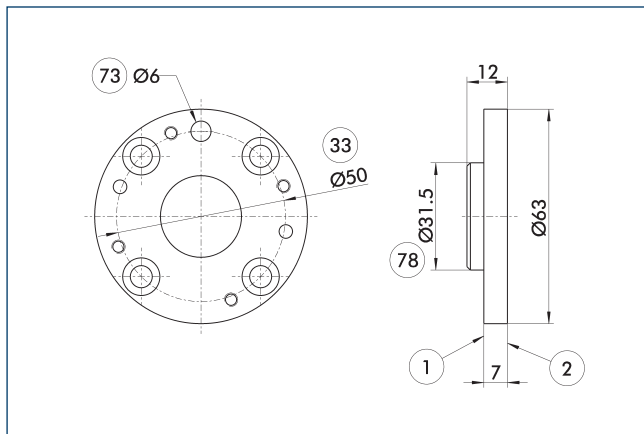

- ① Robot-side connection
- ② Tool-side connection
- ③③ DIN ISO-9409 bolt circle
- ⑦③ Fit for centering pins
- ⑦⑧ Fit for centering

Robot-side adapter plate to mount the OPR to a mounting pattern according to ISO 9409-50-4-M6.

Description	ID	
Robot side		
A-OPR-061-ISO-A50-R	0321371	

Adapter plate ISO-9409-A31.5-T

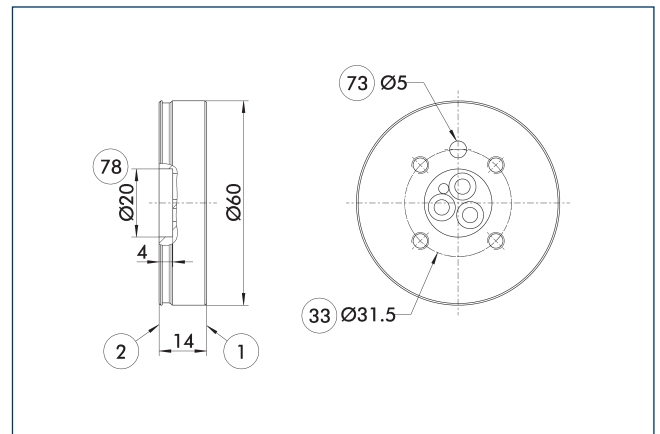

- ① Robot-side connection
- ② Tool-side connection
- ③③ DIN ISO-9409 bolt circle
- ⑦③ Fit for centering pins
- ⑦⑧ Fit for centering

Tool-side adapter plate with ISO 9409 screw connection pattern.

Description	ID	
Tool side		
A-OPR-061-ISO-A31-T	0321372	

Adapter plate ISO 9409-A40-T

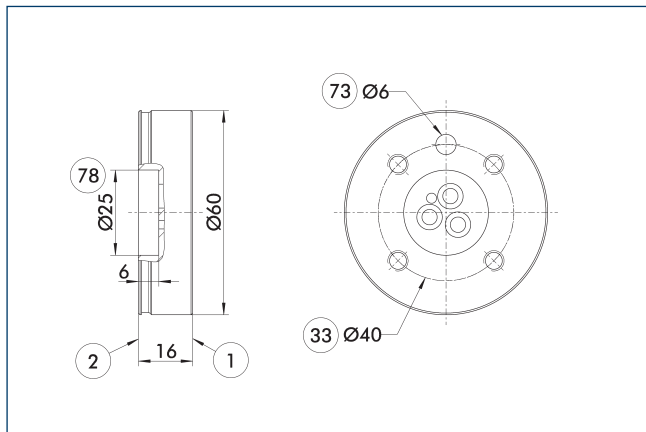

- ① Robot-side connection
- ② Tool-side connection
- ③③ DIN ISO-9409 bolt circle
- ⑦③ Fit for centering pins
- ⑦⑧ Fit for centering

Tool-side adapter plate with ISO 9409 screw connection pattern.

Description	ID
Tool side	
A-OPR-061-ISO-A40-T	0321373

Adapter plate ISO 9409-A50-T

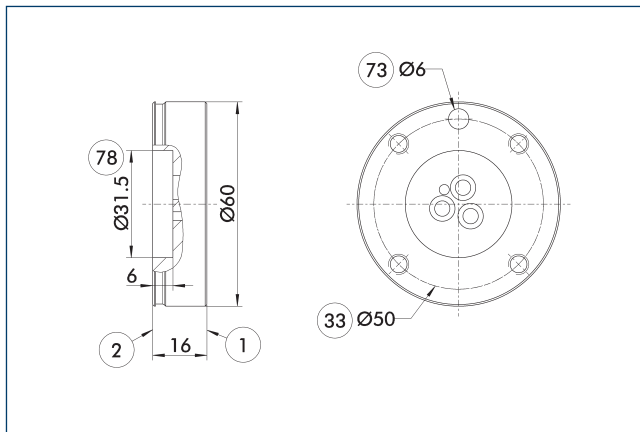

- ① Robot-side connection
- ② Tool-side connection
- ③③ DIN ISO-9409 bolt circle
- ⑦③ Fit for centering pins
- ⑦⑧ Fit for centering

Tool-side adapter plate with ISO 9409 screw connection pattern.

Description	ID
Tool side	
A-OPR-061-ISO-A50-T	0321374

Adapter plate BLANK-T

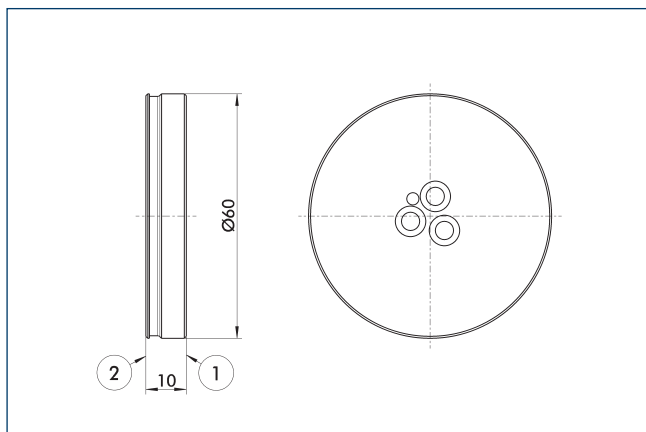

- ① Robot-side connection
- ② Tool-side connection

Unfinished tool-side adapter to be machined by the customer.

Description	ID
Tool side	
A-OPR-061-BLANK-T	0321375

Protection cover OPR-061

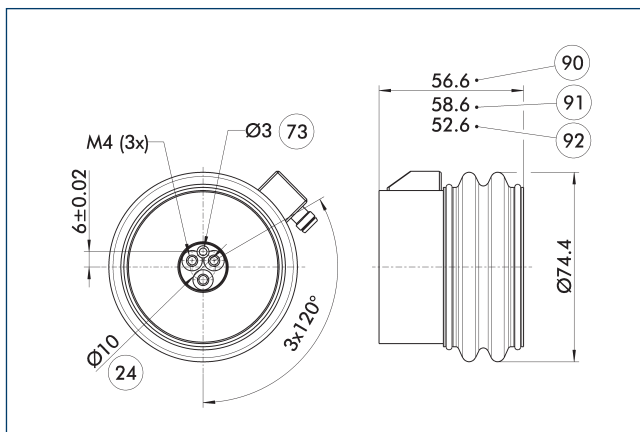

- ②④ Bolt circle
- ⑦③ Fit for centering pins
- ⑨① Total height with adapter plate with flange pattern according to ISO 9409-A40/A50
- ⑨② Total height with adapter plate without flange pattern

The protection boot protects the OPR against coolants for use up to IP 65.

Description	ID	IP protection class
Protection cover		
OPR-061 Flexboot	0321376	65

① Please note that when using the protection boot a tool side adapter plate is also needed.

OPR 081

Anti-collision and overload protection sensor



Triggering torque Mx, My, Mz

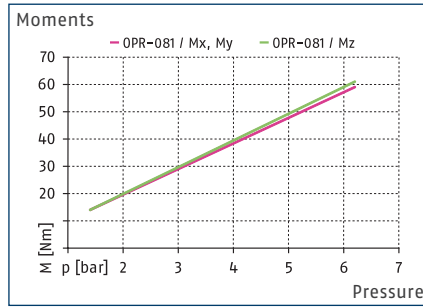

Triggering force Fd

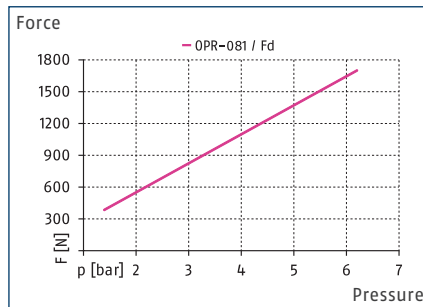

Dimensions and maximum loads

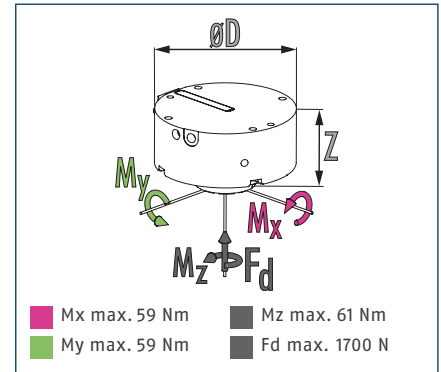

① The design of a collision sensor is defined by the occurring forces and moments in your application.

Technical data

Description		OPR-081-P00	OPR-081-P05	OPR-081-P10	OPR-081-P15
ID		0321381	0321382	0321383	0321384
Axial deflection	[mm]	8.6	8.6	8.6	8.6
Angular deflection	[°]	±13	±13	±13	±13
Deflection rotatory	[°]	±25	±25	±25	±25
Min. triggering moment, angular Mx, My	[Nm]	14	17.3	20.6	24
Min. triggering torque, rotatory Mz	[Nm]	14	17.5	21	24.5
Spring triggering force	[N]		95	191	286
Spring release torque, angular	[Nm]		3.3	6.6	10
Spring release torque, rotatory	[Nm]		3.5	7	10.5
Supply voltage	[V]	10/30	10/30	10/30	10/30
Repeat accuracy	[mm]	±0.025	±0.025	±0.025	±0.025
Responsiveness	[mm]	0.5	0.5	0.5	0.5
Repeat accuracy, rotary	[min]	5	5	5	5
Min./nom./max. operating pressure	[bar]	1.4/-/6.2	1.4/-/5.9	1.4/-/5.5	1.4/-/5.2
Weight	[kg]	0.58	0.6	0.6	0.6
Min./max. ambient temperature	[°C]	5/60	5/60	5/60	5/60
Dimensions Ø D x Z	[mm]	80 x 55.4	80 x 55.4	80 x 55.4	80 x 55.4
Options and their characteristics					
Splash-proof version		OPR-081-P00-S	OPR-081-P05-S	OPR-081-P10-S	OPR-081-P15-S
ID		0321385	0321386	0321387	0321388
IP protection class		65	65	65	65

Main view

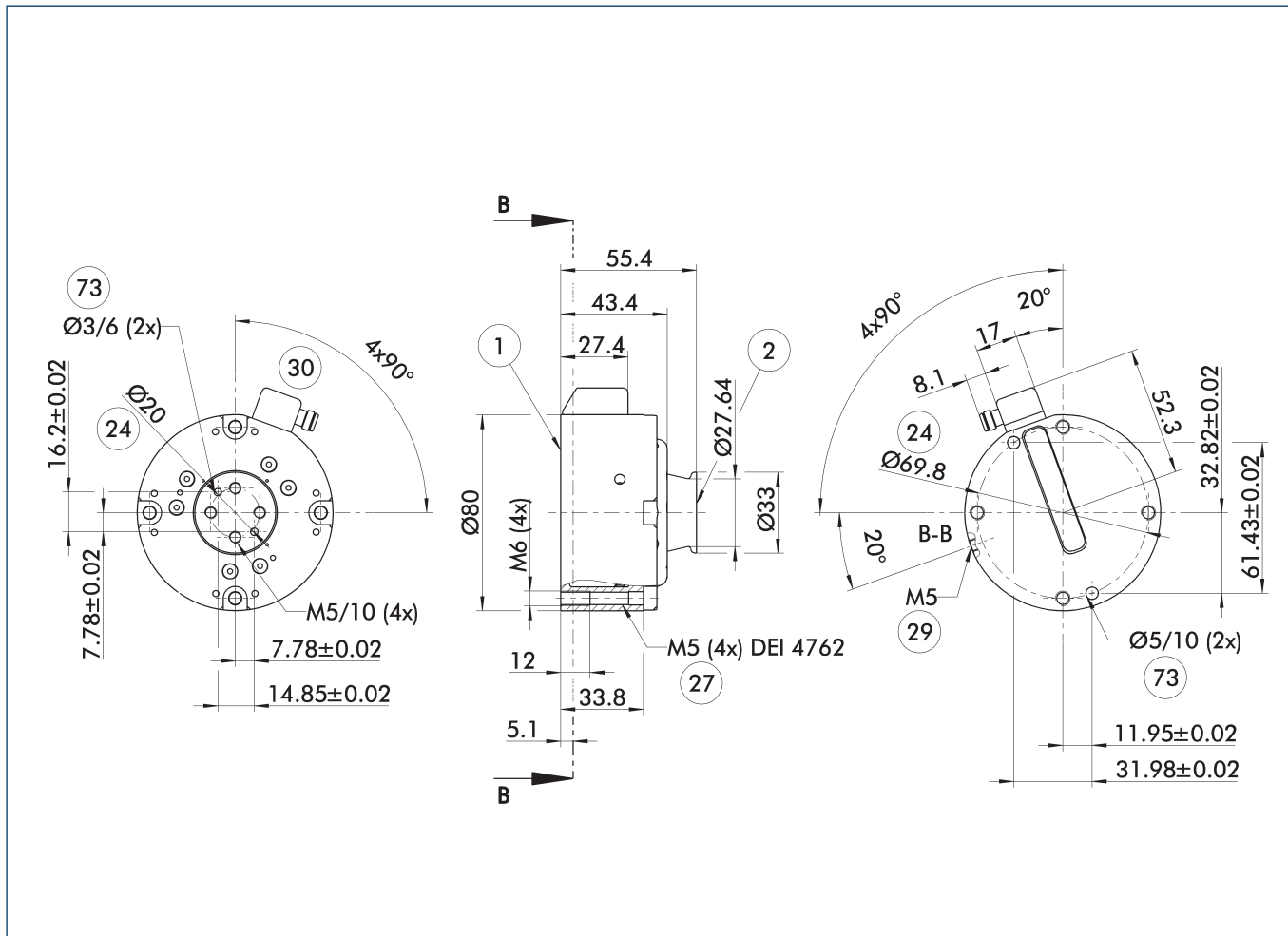

The main view shows the unit in its basic version.

- ① Robot-side connection
- ② Tool-side connection
- ④ Bolt circle
- ⑦ Through holes for screw connections
- ⑨ Air connection P
- ⑩ Cable connector in enclosed pack with 5 m connection cable
- ⑳ Fit for centering pins

Moment loading

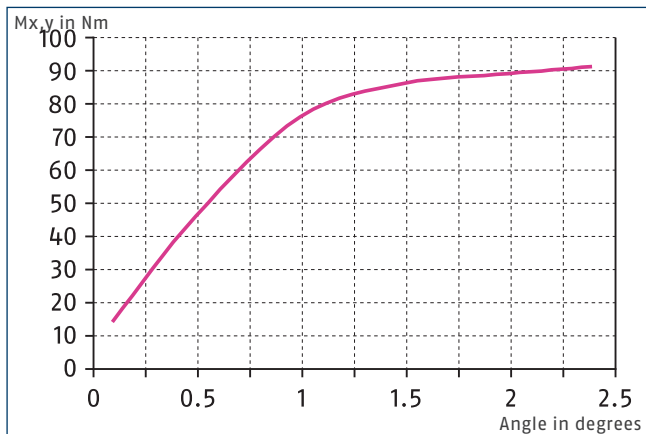

Splash-proof version

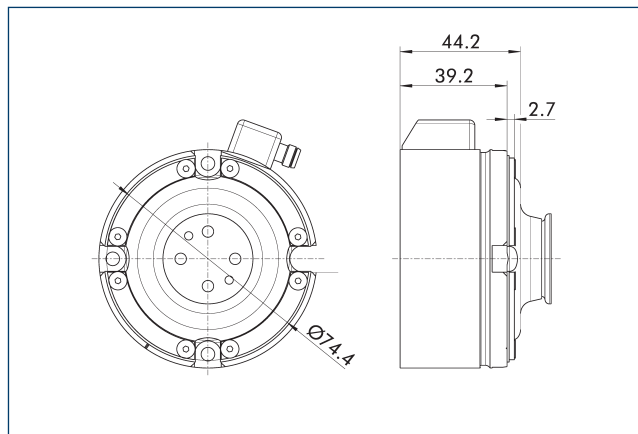

When using the splash water protection version, please be aware of the differences compared to the basic version.

OPR 081

Anti-collision and overload protection sensor

Adapter plate ISO 9409-A50-R

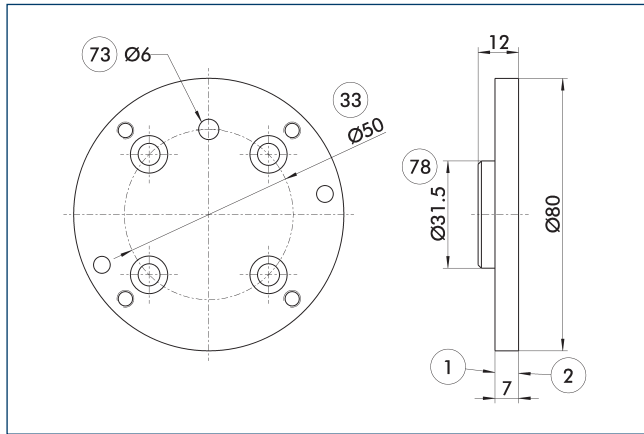

- ① Robot-side connection
- ② Tool-side connection
- ③ DIN ISO-9409 bolt circle
- ⑦③ Fit for centering pins
- ⑦⑧ Fit for centering

Robot-side adapter plate to mount the OPR to a mounting pattern according to ISO 9409-50-4-M6.

Description	ID
Robot side	
A-OPR-081-ISO-A50-R	0321190

Adapter plate ISO 9409-A63-R

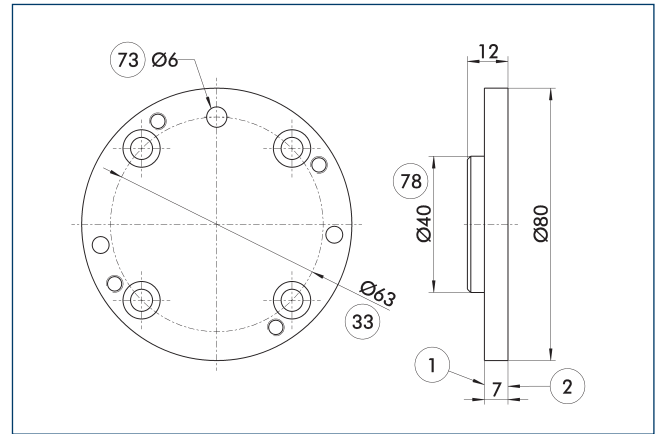

- ① Robot-side connection
- ② Tool-side connection
- ③ DIN ISO-9409 bolt circle
- ⑦③ Fit for centering pins
- ⑦⑧ Fit for centering

Robot-side adapter plate to mount the OPR to a mounting pattern according to ISO 9409-63-4-M6.

Description	ID
Robot side	
A-OPR-081-ISO-A63-R	0321191

Adapter plate ISO 9409-A50-T

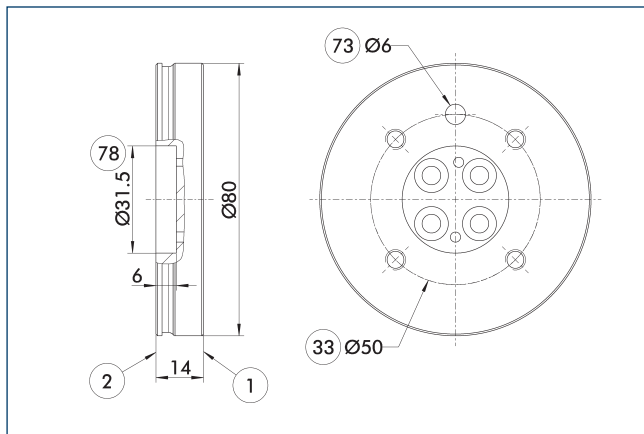

- ① Robot-side connection
- ② Tool-side connection
- ③ DIN ISO-9409 bolt circle
- ⑦③ Fit for centering pins
- ⑦⑧ Fit for centering

Tool-side adapter plate with ISO 9409 screw connection pattern.

Description	ID
Tool side	
A-OPR-081-ISO-A50-T	0321192

Adapter plate ISO 9409-A63-T

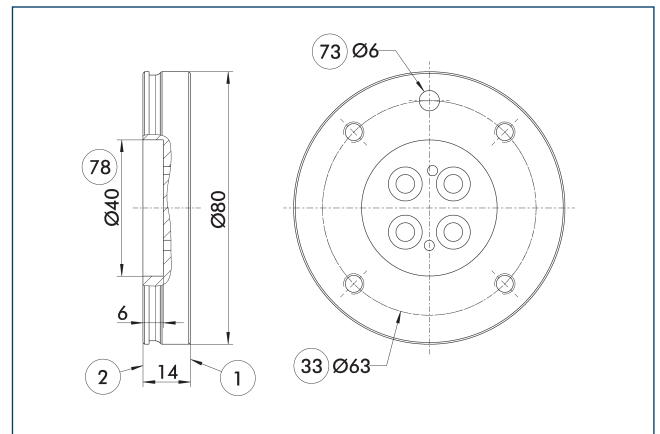

- ① Robot-side connection
- ② Tool-side connection
- ③ DIN ISO-9409 bolt circle
- ⑦③ Fit for centering pins
- ⑦⑧ Fit for centering

Tool-side adapter plate with ISO 9409 screw connection pattern.

Description	ID
Tool side	
A-OPR-081-ISO-A63-T	0321193

Adapter plate BLANK-T

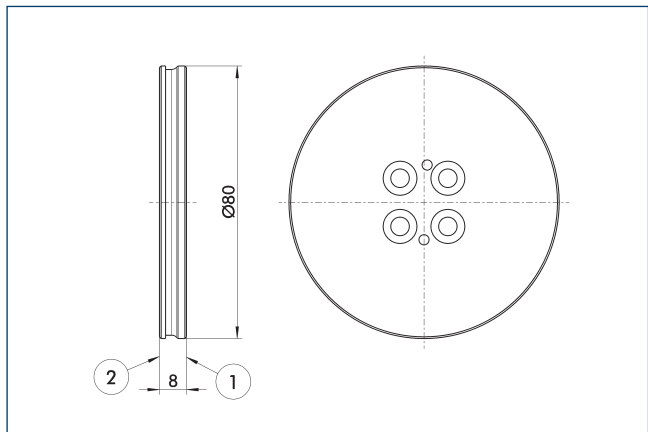

- ① Robot-side connection
- ② Tool-side connection

Unfinished tool-side adapter to be machined by the customer.

Description	ID
Tool side	
A-OPR-081-BLANK-T	0321194

Protection cover OPR-081

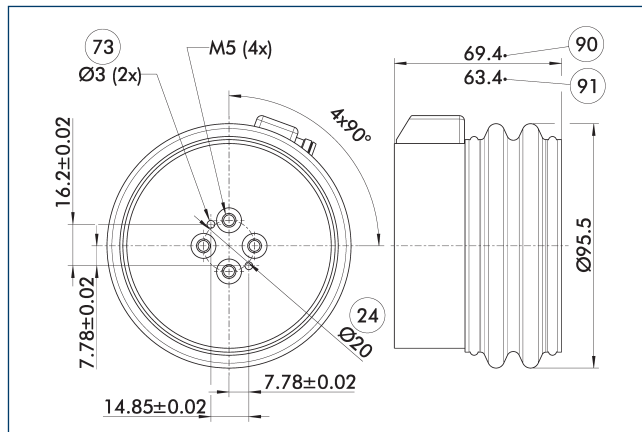

- ②④ Bolt circle
- ⑦③ Fit for centering pins
- ⑨① Total height with adapter plate with flange pattern according to ISO 9409-A50/A63
- ⑨① Total height with adapter plate without flange pattern

The protection boot protects the OPR against coolants for use up to IP 65.

Description	ID	IP protection class
Protection cover		
OPR-081 Flexboot	0321195	65

- ① Please note that when using the protection boot a tool side adapter plate is also needed.

OPR 101

Anti-collision and overload protection sensor



Triggering torque Mx, My, Mz

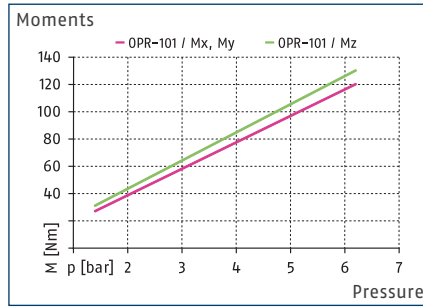

Triggering force Fd

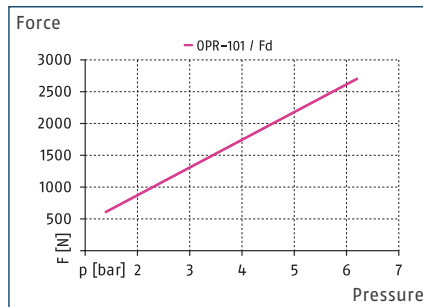

Dimensions and maximum loads

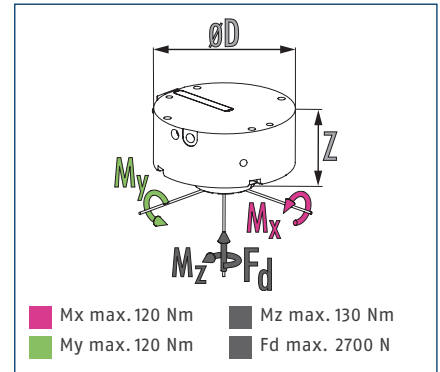

① The design of a collision sensor is defined by the occurring forces and moments in your application.

Technical data

Description		OPR-101-P00	OPR-101-P05	OPR-101-P10	OPR-101-P15
ID		0321401	0321402	0321403	0321404
Axial deflection	[mm]	10	10	10	10
Angular deflection	[°]	±12	±12	±12	±12
Deflection rotatory	[°]	±25	±25	±25	±25
Min. triggering moment, angular Mx, My	[Nm]	27	33.6	40.3	46.9
Min. triggering torque, rotatory Mz	[Nm]	31	39	46.9	54.9
Spring triggering force	[N]		151	303	454
Spring release torque, angular	[Nm]		6.6	13.3	19.9
Spring release torque, rotatory	[Nm]		8	15.9	23.9
Supply voltage	[V]	10/30	10/30	10/30	10/30
Repeat accuracy	[mm]	±0.025	±0.025	±0.025	±0.025
Responsiveness	[mm]	0.5	0.5	0.5	0.5
Repeat accuracy, rotary	[min]	5	5	5	5
Min./nom./max. operating pressure	[bar]	1.4/-/6.2	1.4/-/5.9	1.4/-/5.5	1.4/-/5.2
Weight	[kg]	1.2	1.3	1.3	1.3
Min./max. ambient temperature	[°C]	5/60	5/60	5/60	5/60
Dimensions Ø D x Z	[mm]	100.1 x 63	100.1 x 63	100.1 x 63	100.1 x 63
Options and their characteristics					
Splash-proof version		OPR-101-P00-S	OPR-101-P05-S	OPR-101-P10-S	OPR-101-P15-S
ID		0321405	0321406	0321407	0321408
IP protection class		65	65	65	65

Main view

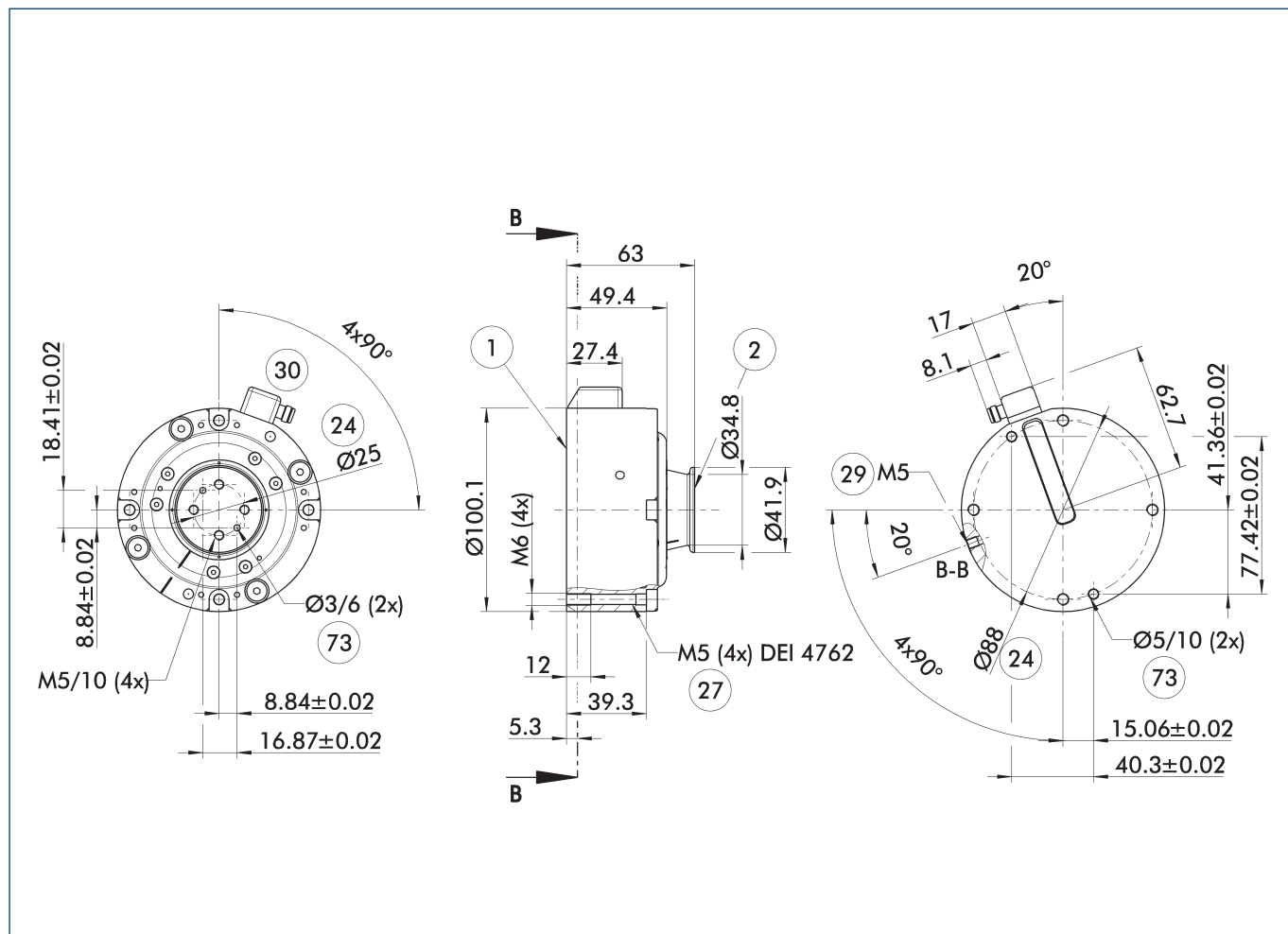

The main view shows the unit in its basic version.

- ① Robot-side connection
- ② Tool-side connection
- ④ Bolt circle
- ⑦ Through holes for screw connections
- ⑨ Air connection P
- ⑩ Cable connector in enclosed pack with 5 m connection cable
- ⑬ Fit for centering pins

Moment loading

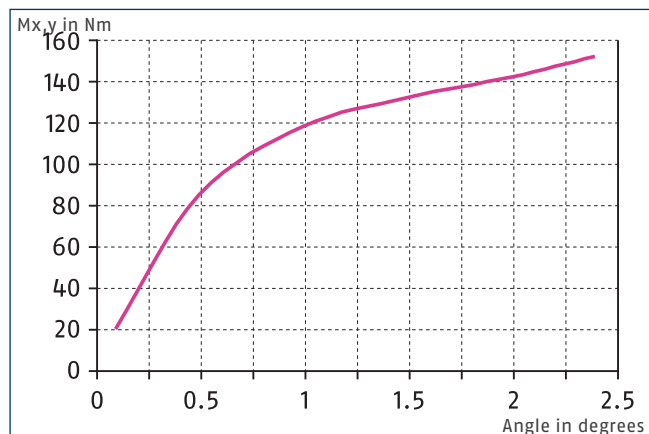

The diagram shows the angular deflection of the OPR according to the moment M_x , M_y with maximum permissible operating pressure.

OPR 101

Anti-collision and overload protection sensor

Adapter plate ISO 9409-A50-R

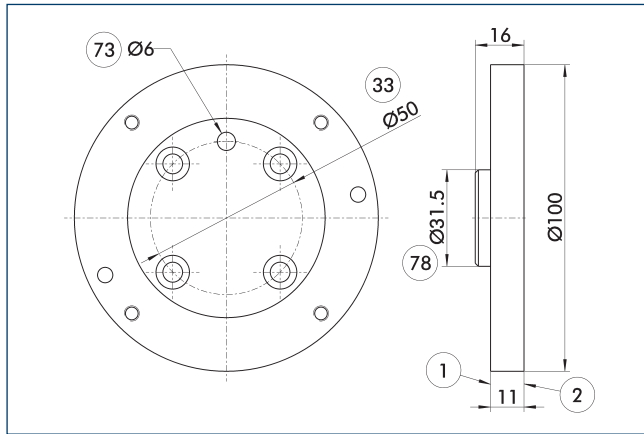

- ① Robot-side connection
- ② Tool-side connection
- ③ DIN ISO-9409 bolt circle
- ⑦③ Fit for centering pins
- ⑦⑧ Fit for centering

Robot-side adapter plate to mount the OPR to a mounting pattern according to ISO 9409-50-4-M6.

Description	ID
Robot side	
A-OPR-101-ISO-A50-R	0321410

Adapter plate ISO 9409-A63-R

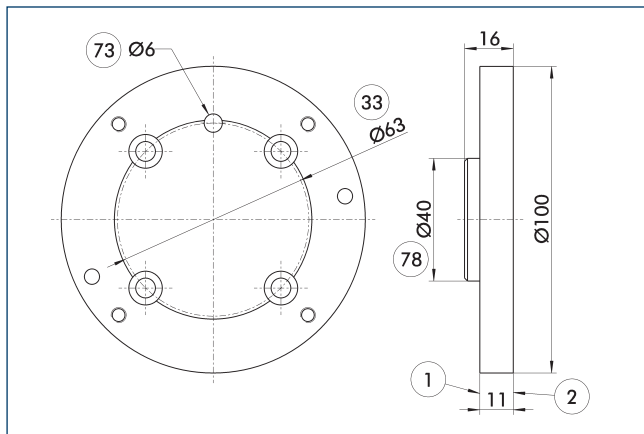

- ① Robot-side connection
- ② Tool-side connection
- ③ DIN ISO-9409 bolt circle
- ⑦③ Fit for centering pins
- ⑦⑧ Fit for centering

Robot-side adapter plate to mount the OPR to a mounting pattern according to ISO 9409-63-4-M6.

Description	ID
Robot side	
A-OPR-101-ISO-A63-R	0321411

Adapter plate ISO 9409-A80-R

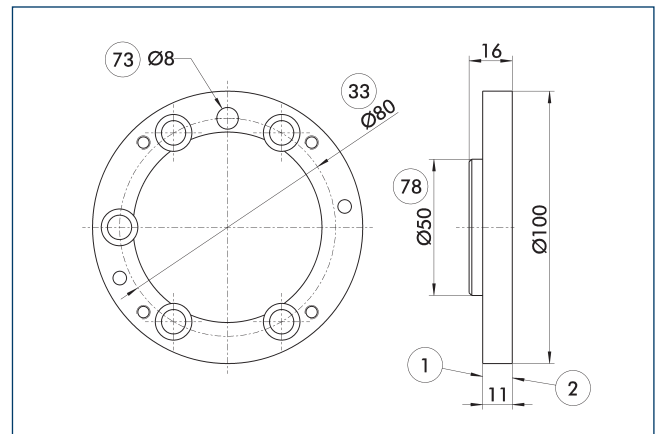

- ① Robot-side connection
- ② Tool-side connection
- ③ DIN ISO-9409 bolt circle
- ⑦③ Fit for centering pins
- ⑦⑧ Fit for centering

Robot-side adapter plate to mount the OPR to a mounting pattern according to ISO 9409-80-6-M8.

Description	ID
Robot side	
A-OPR-101-ISO-A80-R	0321412

Adapter plate ISO 9409-A50-T

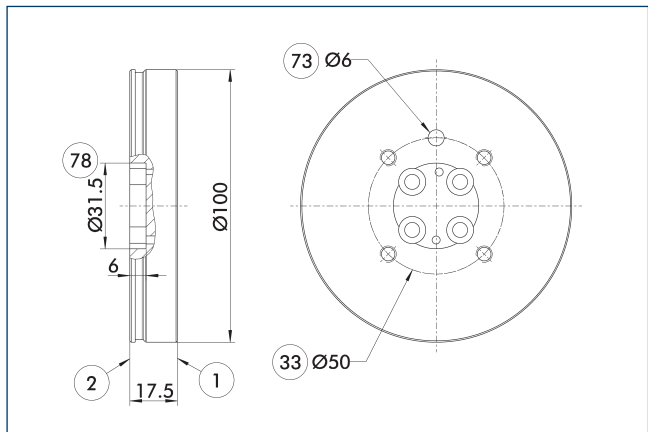

- ① Robot-side connection
- ② Tool-side connection
- ③③ DIN ISO-9409 bolt circle
- ⑦③ Fit for centering pins
- ⑦⑧ Fit for centering

Tool-side adapter plate with ISO 9409 screw connection pattern.

Description	ID
Tool side	
A-OPR-101-ISO-A50-T	0321413

Adapter plate ISO 9409-A63-T

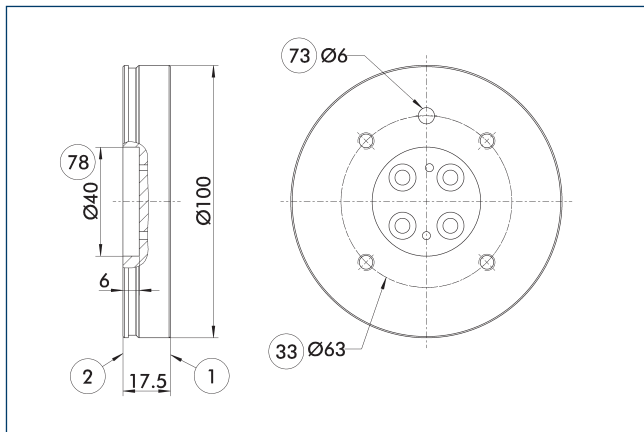

- ① Robot-side connection
- ② Tool-side connection
- ③③ DIN ISO-9409 bolt circle
- ⑦③ Fit for centering pins
- ⑦⑧ Fit for centering

Tool-side adapter plate with ISO 9409 screw connection pattern.

Description	ID
Tool side	
A-OPR-101-ISO-A63-T	0321414

Adapter plate ISO 9409-A80-T

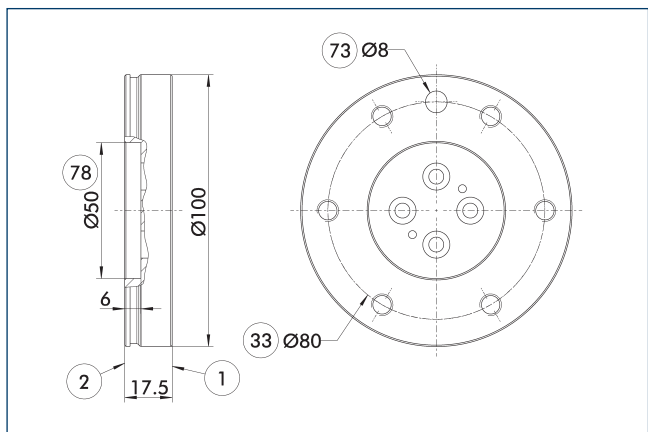

- ① Robot-side connection
- ② Tool-side connection
- ③③ DIN ISO-9409 bolt circle
- ⑦③ Fit for centering pins
- ⑦⑧ Fit for centering

Tool-side adapter plate with ISO 9409 screw connection pattern.

Description	ID
Tool side	
A-OPR-101-ISO-A80-T	0321415

Adapter plate BLANK-T

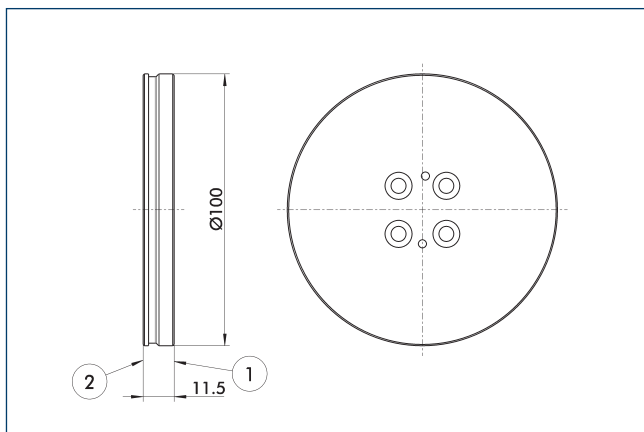

- ① Robot-side connection
- ② Tool-side connection

Unfinished tool-side adapter to be machined by the customer.

Description	ID
Tool side	
A-OPR-101-BLANK-T	0321417

OPR 101

Anti-collision and overload protection sensor

Protection cover OPR-101

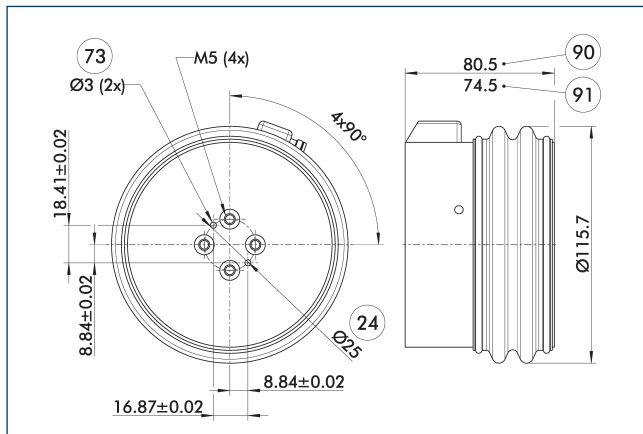

- ②④ Bolt circle
- ⑦③ Fit for centering pins
- ⑨⑩ Total height with adapter plate with flange pattern according to ISO 9409-A50/A63/A80
- ⑨① Total height with adapter plate without flange pattern

The protection boot protects the OPR against coolants for use up to IP 65.

Description	ID	IP protection class
Protection cover		
OPR-101 Flexboot	0321416	65

- ① Please note that when using the protection boot a tool side adapter plate is also needed.

Splash-proof version

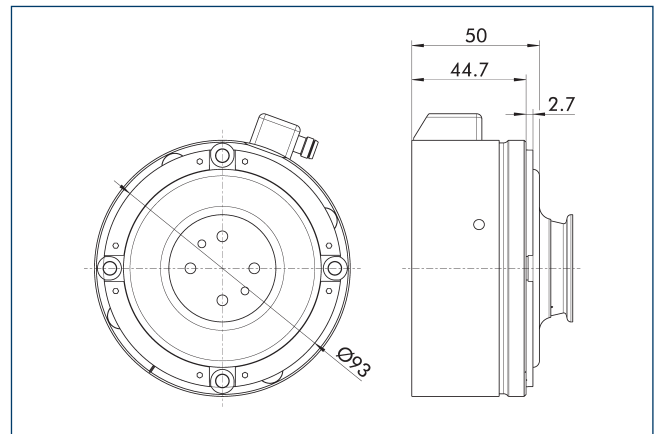

When using the splash water protection version, please be aware of the differences compared to the basic version.

OPR 131

Anti-collision and overload protection sensor



Triggering torque Mx, My, Mz

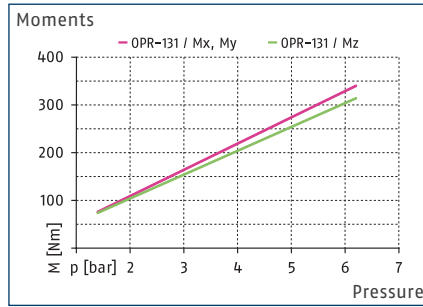

Triggering force Fd

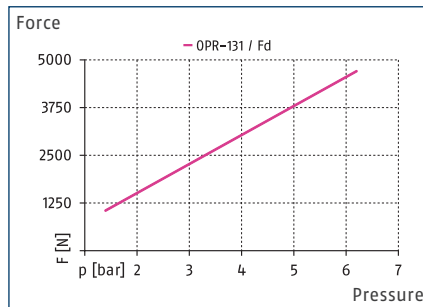

Dimensions and maximum loads

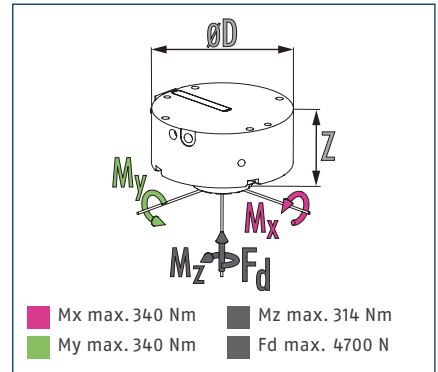

① The design of a collision sensor is defined by the occurring forces and moments in your application.

Technical data

Description		OPR-131-P00	OPR-131-P05	OPR-131-P10
ID		0321431	0321432	0321433
Axial deflection	[mm]	11.5	11.5	11.5
Angular deflection	[°]	±10	±10	±10
Deflection rotatory	[°]	±20	±20	±20
Min. triggering moment, angular Mx, My	[Nm]	76	94.8	113.7
Min. triggering torque, rotatory Mz	[Nm]	74	92.6	111.1
Spring triggering force	[N]		262	523
Spring release torque, angular	[Nm]		18.8	37.7
Spring release torque, rotatory	[Nm]		18.6	37.1
Supply voltage	[V]	10/30	10/30	10/30
Repeat accuracy	[mm]	±0.025	±0.025	±0.025
Responsiveness	[mm]	0.5	0.5	0.5
Repeat accuracy, rotary	[min]	5	5	5
Min./nom./max. operating pressure	[bar]	1.4/-/6.2	1.4/-/5.9	1.4/-/5.5
Weight	[kg]	2.3	2.4	2.4
Min./max. ambient temperature	[°C]	5/60	5/60	5/60
Dimensions Ø D x Z	[mm]	130 x 75	130 x 75	130 x 75
Options and their characteristics				
Splash-proof version		OPR-131-P00-S	OPR-131-P05-S	OPR-131-P10-S
ID		0321435	0321436	0321437
IP protection class		65	65	65

Main view

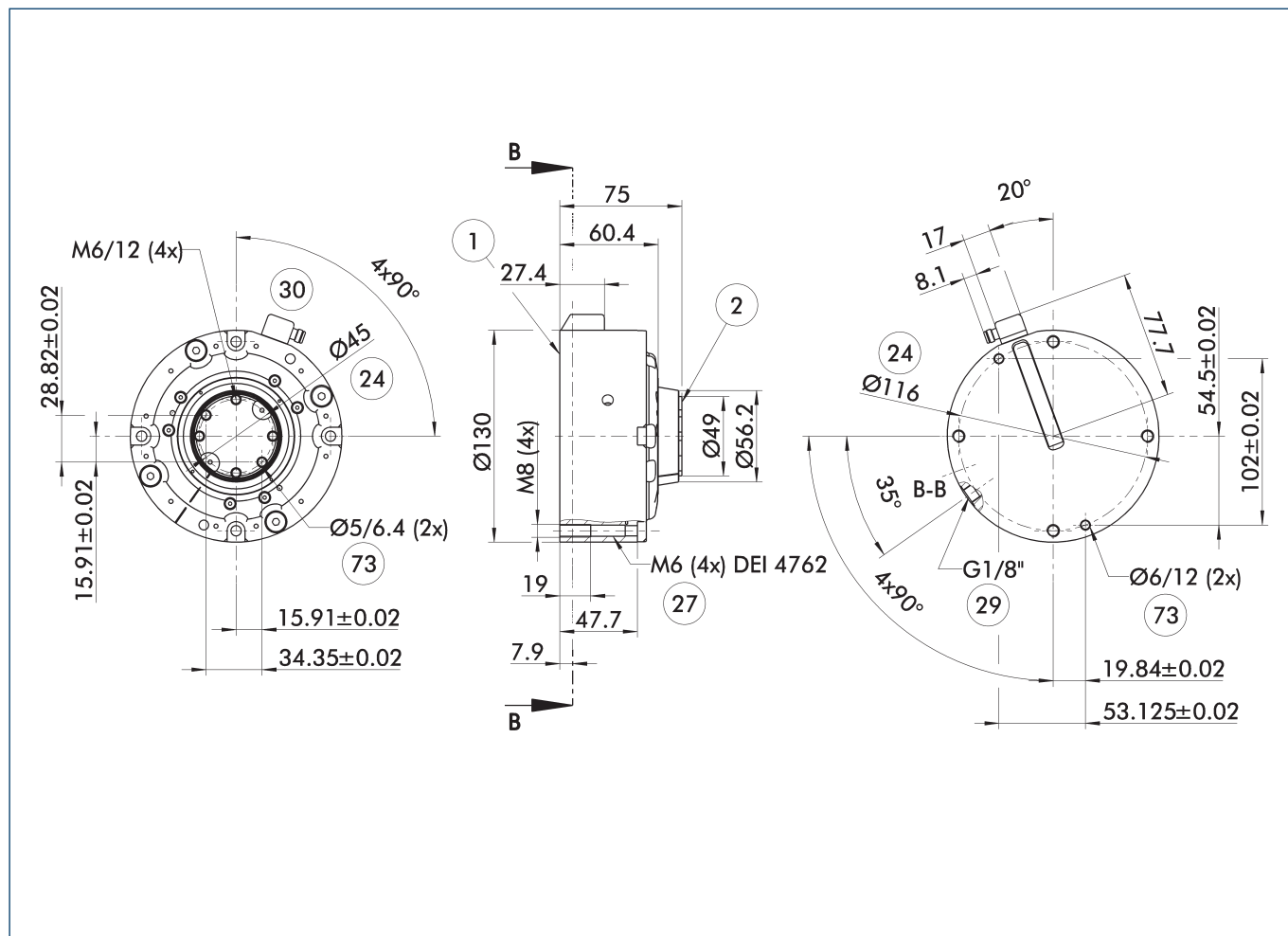

The main view shows the unit in its basic version.

- ① Robot-side connection
- ② Tool-side connection
- ④ Bolt circle
- ⑦ Through holes for screw connections
- ⑨ Air connection P
- ⑩ Cable connector in enclosed pack with 5 m connection cable
- ⑬ Fit for centering pins

Moment loading

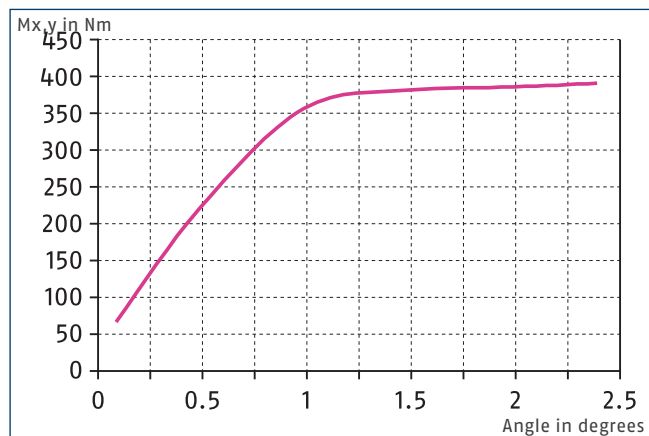

The diagram shows the angular deflection of the OPR according to the moment M_x , M_y with maximum permissible operating pressure.

OPR 131

Anti-collision and overload protection sensor

Adapter plate ISO 9409-A80-R

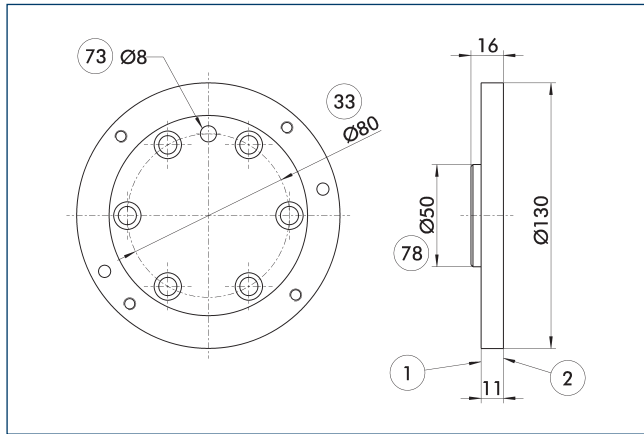

- ① Robot-side connection
- ② Tool-side connection
- ③ DIN ISO-9409 bolt circle
- ⑦③ Fit for centering pins
- ⑦⑧ Fit for centering

Robot-side adapter plate to mount the OPR to a mounting pattern according to ISO 9409-80-6-M8.

Description	ID
Robot side	
A-OPR-131-ISO-A80-R	0321440

Adapter plate ISO 9409-A100-R

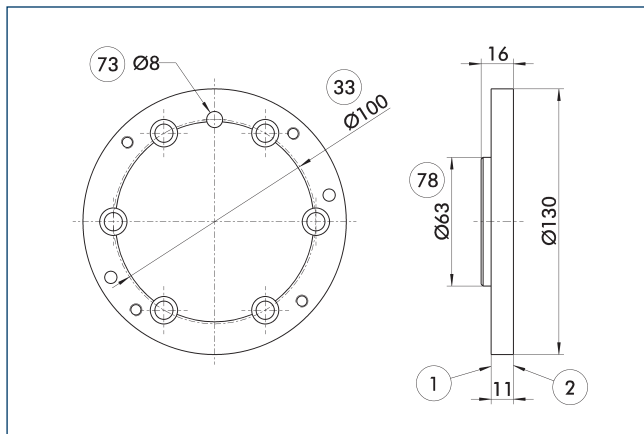

- ① Robot-side connection
- ② Tool-side connection
- ③ DIN ISO-9409 bolt circle
- ⑦③ Fit for centering pins
- ⑦⑧ Fit for centering

Robot-side adapter plate to mount the OPR to a mounting pattern according to ISO 9409-100-6-M8.

Description	ID
Robot side	
A-OPR-131-ISO-A100-R	0321441

Adapter plate ISO 9409-A80-T

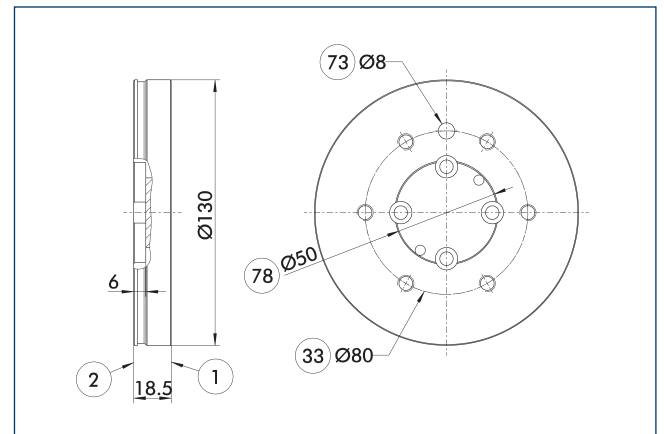

- ① Robot-side connection
- ② Tool-side connection
- ③ DIN ISO-9409 bolt circle
- ⑦③ Fit for centering pins
- ⑦⑧ Fit for centering

Tool-side adapter plate with ISO 9409 screw connection pattern.

Description	ID
Tool side	
A-OPR-131-ISO-A80-T	0321444

Adapter plate ISO 9409-A100-T

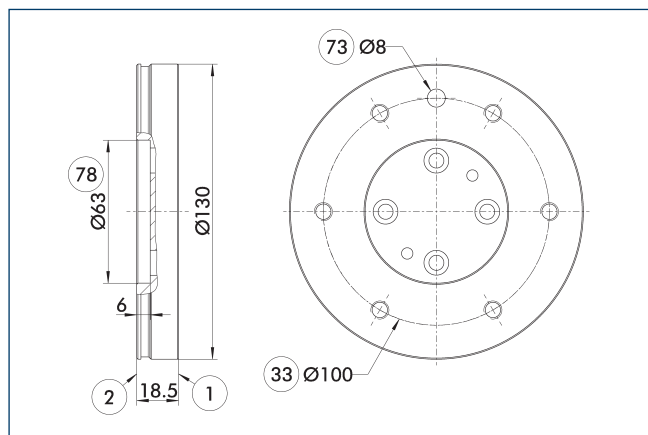

- ① Robot-side connection
- ② Tool-side connection
- ③ DIN ISO-9409 bolt circle
- ⑦③ Fit for centering pins
- ⑦⑧ Fit for centering

Tool-side adapter plate with ISO 9409 screw connection pattern.

Description	ID	
Tool side		
A-OPR-131-ISO-A100-T	0321550	

Adapter plate BLANK-T

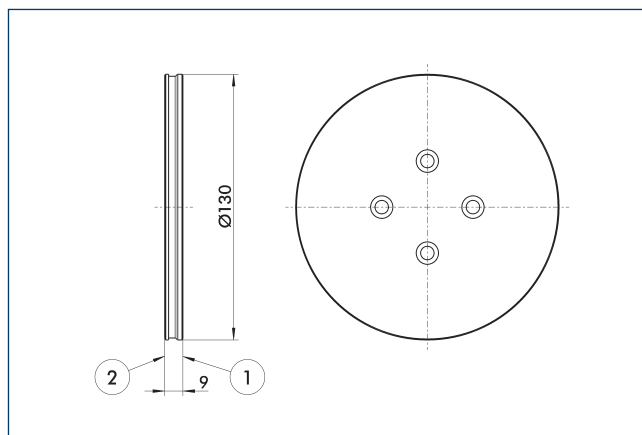

- ① Robot-side connection
- ② Tool-side connection

Unfinished tool-side adapter to be machined by the customer.

Description	ID	
Tool side		
A-OPR-131-BLANK-T	0321551	

Protection cover OPR-131

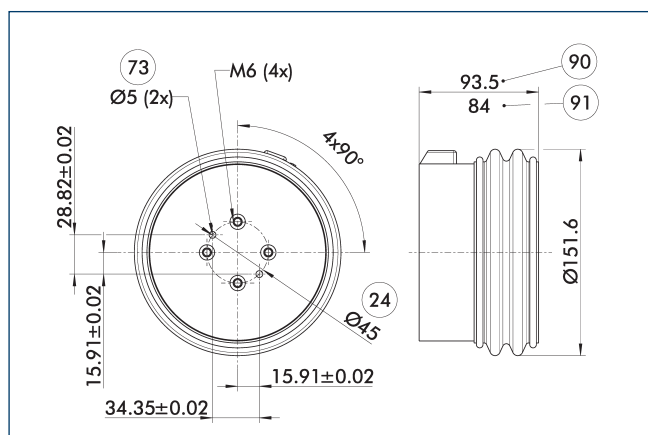

- ②④ Bolt circle
- ⑦③ Fit for centering pins
- ⑨① Total height with adapter plate with flange pattern ISO 9409
- ⑨② Total height with adapter plate without flange pattern

The protection boot protects the OPR against coolants for use up to IP 65.

Description	ID	IP protection class
Protection cover		
OPR-131 Flexboot	0321447	65

- ① Please note that when using the protection boot a tool side adapter plate is also needed.

Splash-proof version

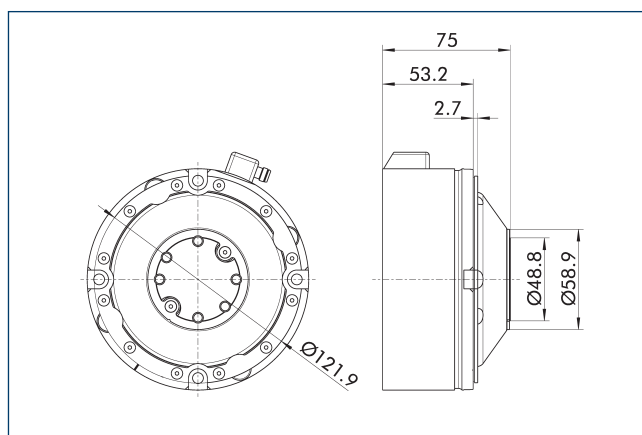

When using the splash water protection version, please be aware of the differences compared to the basic version.

OPR 176

Anti-collision and overload protection sensor



Triggering torque Mx, My, Mz

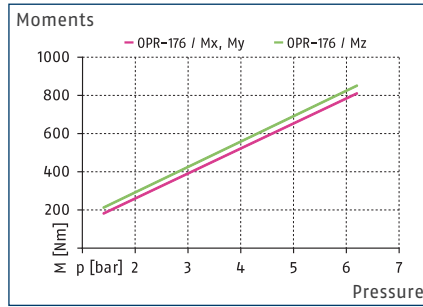

Triggering force Fd

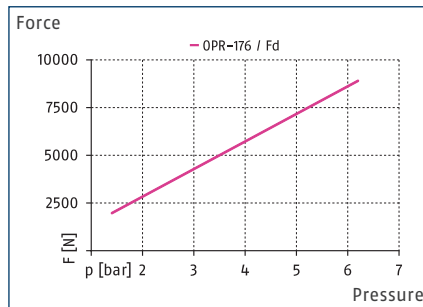

Dimensions and maximum loads

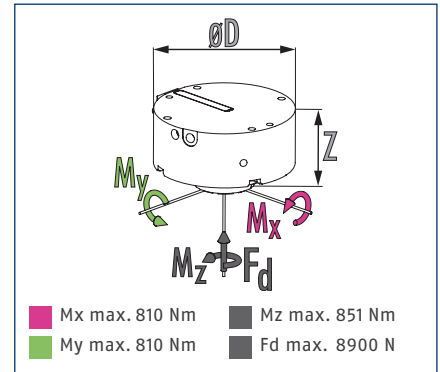

① The design of a collision sensor is defined by the occurring forces and moments in your application.

Technical data

Description		OPR-176-P00	OPR-176-P05	OPR-176-P10	OPR-176-P15
ID		0321476	0321477	0321478	0321479
Axial deflection	[mm]	16	16	16	16
Angular deflection	[°]	±10	±10	±10	±10
Deflection rotatory	[°]	±20	±20	±20	±20
Min. triggering moment, angular Mx, My	[Nm]	180	223.5	266.9	310
Min. triggering torque, rotatory Mz	[Nm]	211	263.7	316	369
Spring triggering force	[N]		494	988	1483
Spring release torque, angular	[Nm]		43.5	86.9	130
Spring release torque, rotatory	[Nm]		52.7	105	158
Supply voltage	[V]	10/30	10/30	10/30	10/30
Repeat accuracy	[mm]	±0.025	±0.025	±0.025	±0.025
Responsiveness	[mm]	0.5	0.5	0.5	0.5
Repeat accuracy, rotary	[min]	5	5	5	5
Min./nom./max. operating pressure	[bar]	1.4/-/6.2	1.4/-/5.9	1.4/-/5.5	1.4/-/5.2
Weight	[kg]	5.4	5.5	5.5	5.5
Min./max. ambient temperature	[°C]	5/60	5/60	5/60	5/60
Dimensions Ø D x Z	[mm]	175 x 100.1	175 x 100.1	175 x 100.1	175 x 100.1
Options and their characteristics					
Splash-proof version		OPR-176-P00-S	OPR-176-P05-S	OPR-176-P10-S	OPR-176-P15-S
ID		0321480	0321481	0321482	0321483
IP protection class		65	65	65	65

Main view

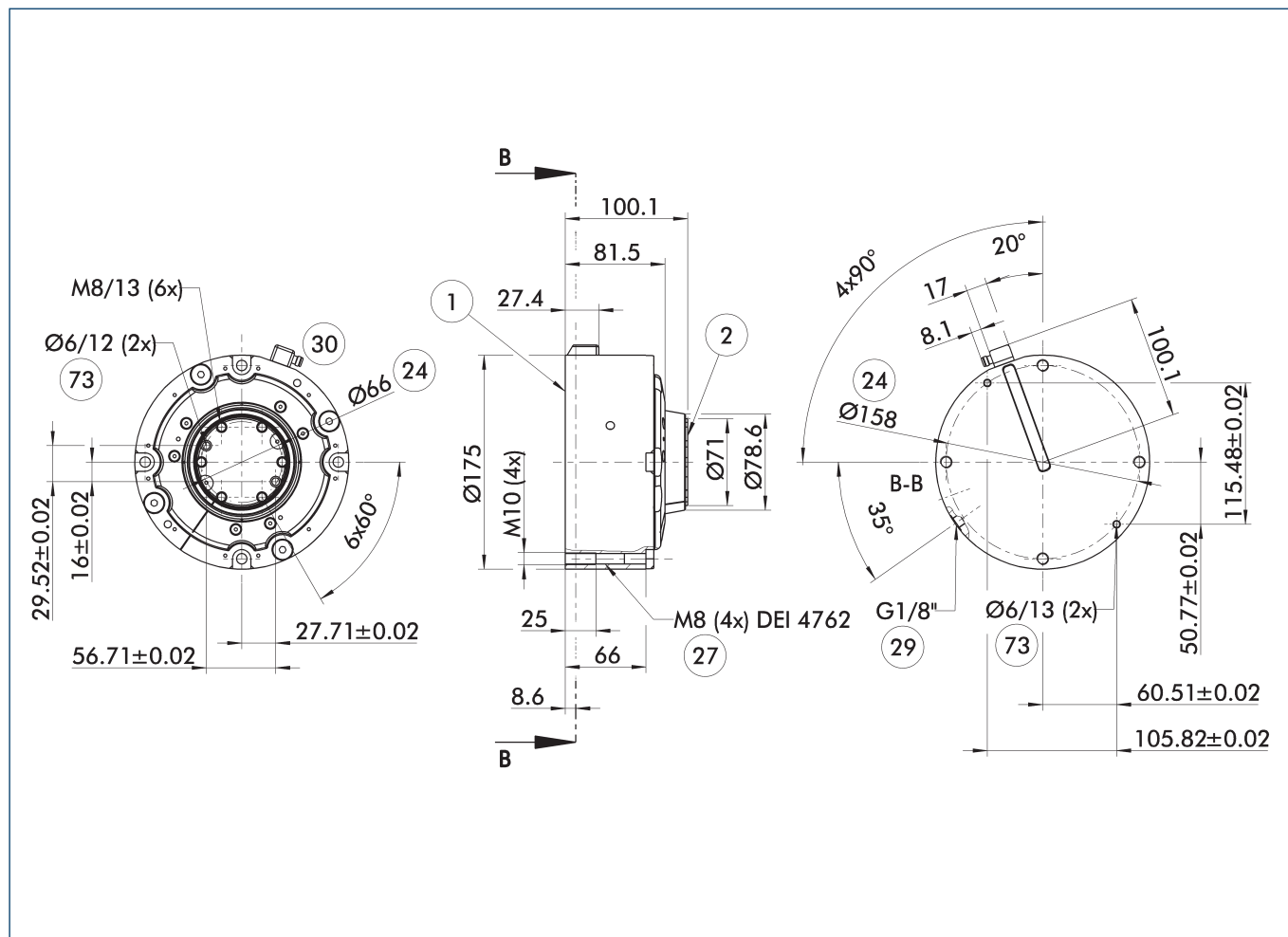

The main view shows the unit in its basic version.

- ① Robot-side connection
- ② Tool-side connection
- ④ Bolt circle
- ⑦ Through holes for screw connections
- ⑨ Air connection P
- ⑩ Cable connector in enclosed pack with 5 m connection cable
- ⑬ Fit for centering pins

Moment loading

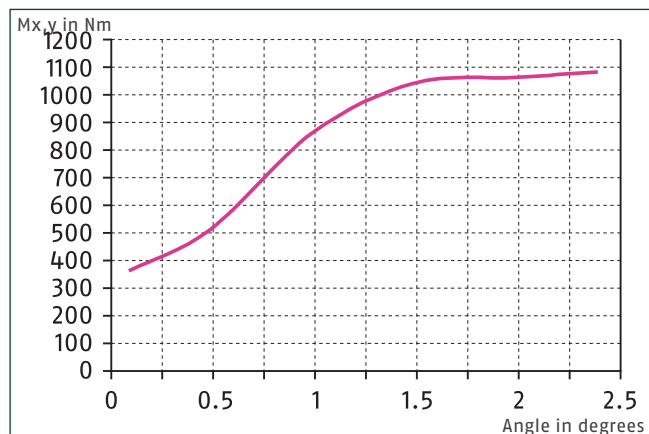

The diagram shows the angular deflection of the OPR according to the moment M_x , M_y with maximum permissible operating pressure.

OPR 176

Anti-collision and overload protection sensor

Adapter plate ISO 9409-A125-R

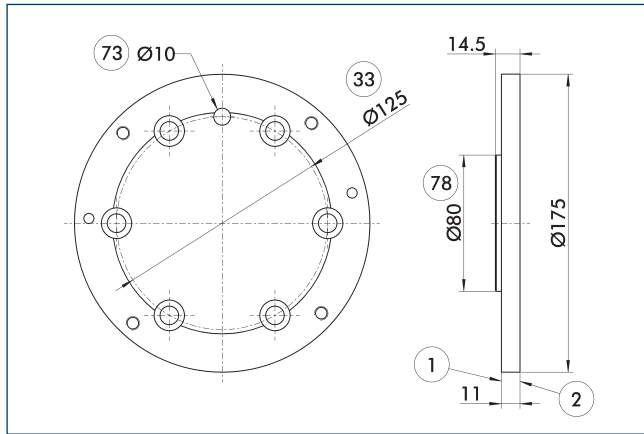

- ① Robot-side connection
- ② Tool-side connection
- ③ DIN ISO-9409 bolt circle
- ⑦③ Fit for centering pins
- ⑦⑧ Fit for centering

Robot-side adapter plate to mount the OPR to a mounting pattern according to ISO 9409-125-6-M10.

Description	ID
Robot side	
A-OPR-176-ISO-A125-R	0321485

Adapter plate ISO 9409-A160-R

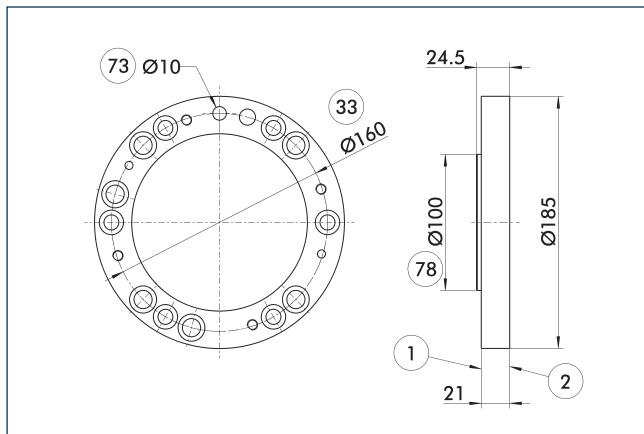

- ① Robot-side connection
- ② Tool-side connection
- ③ DIN ISO-9409 bolt circle
- ⑦③ Fit for centering pins
- ⑦⑧ Fit for centering

Robot-side adapter plate to mount the OPR to a mounting pattern according to ISO 9409-160-6-M10.

Description	ID
Robot side	
A-OPR-176-ISO-A160-R	0321486

Adapter plate ISO 9409-A125-T

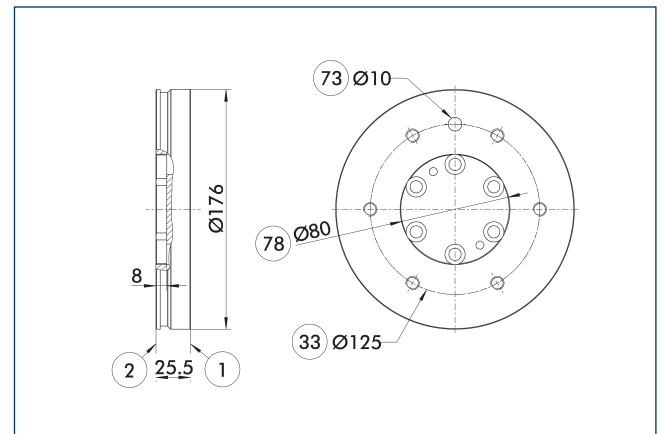

- ① Robot-side connection
- ② Tool-side connection
- ③ DIN ISO-9409 bolt circle
- ⑦③ Fit for centering pins
- ⑦⑧ Fit for centering

Tool-side adapter plate with ISO 9409 screw connection pattern.

Description	ID
Tool side	
A-OPR-176-ISO-A125-T	0321552

Adapter plate ISO 9409-A160-T

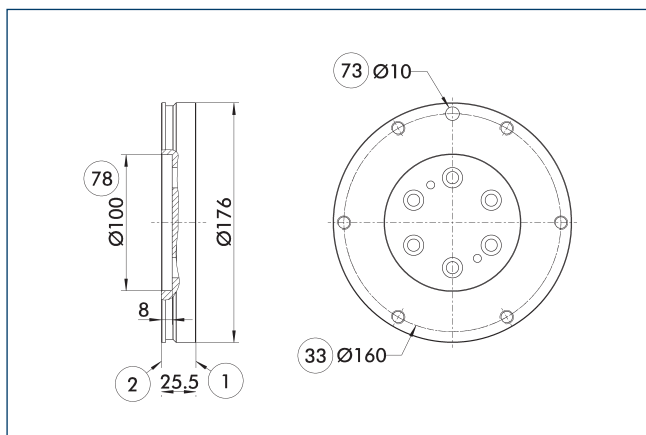

- ① Robot-side connection
- ② Tool-side connection
- ③ DIN ISO-9409 bolt circle
- ⑦③ Fit for centering pins
- ⑦⑧ Fit for centering

Tool-side adapter plate with ISO-9409 screw connection diagram.

Description	ID
Tool side	
A-OPR-176-ISO-A160-T	0321553

Adapter plate BLANK-T

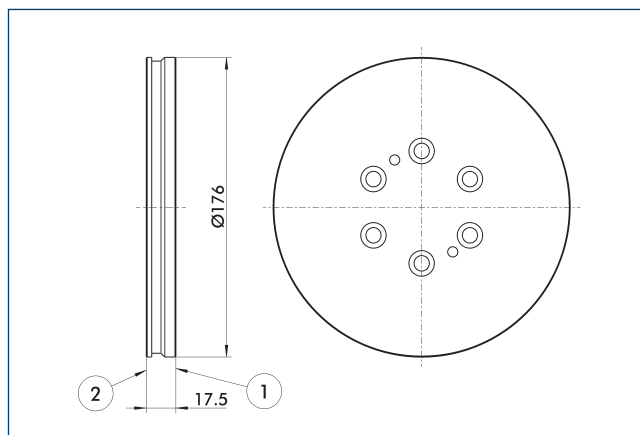

- ① Robot-side connection
- ② Tool-side connection

Unfinished tool-side adapter to be machined by the customer.

Description	ID
Tool side	
A-OPR-176-BLANK-T	0321489

Protection cover OPR-176

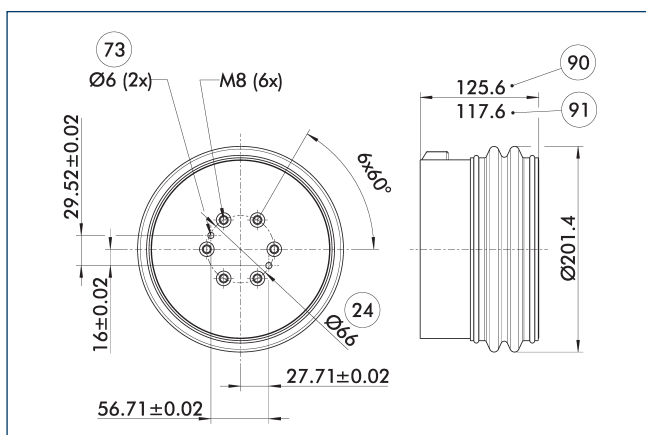

- ②④ Bolt circle
- ⑦③ Fit for centering pins
- ⑨① Total height with adapter plate without flange pattern
- ⑨② Total height with adapter plate with flange pattern according to ISO 9409-A125/A160

The protection boot protects the OPR against coolants for use up to IP 65.

Description	ID	IP protection class
Protection cover		
OPR-176 Flexboot	0321492	65

① Please note that when using the protection boot a tool side adapter plate is also needed.

Splash-proof version

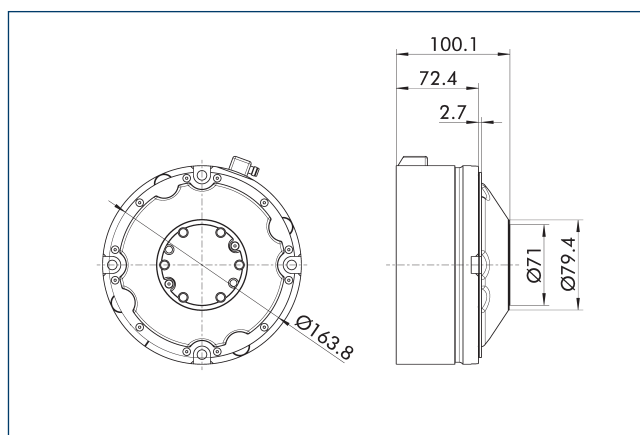

When using the splash water protection version, please be aware of the differences compared to the basic version.

OPR 221

Anti-collision and overload protection sensor



Triggering torque Mx, My, Mz

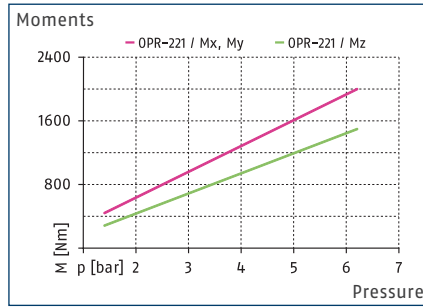

Triggering force Fd

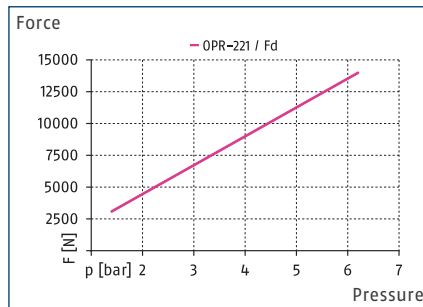

Dimensions and maximum loads

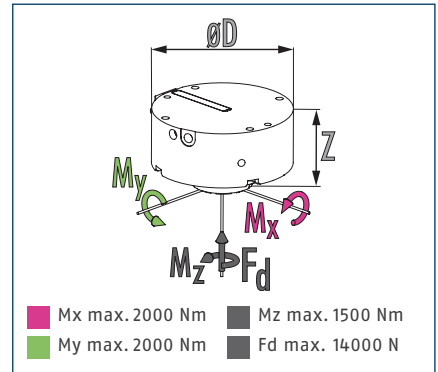

① The design of a collision sensor is defined by the occurring forces and moments in your application.

Technical data

Description		OPR-221-P00	OPR-221-P05	OPR-221-P10	OPR-221-P15
ID		0321521	0321522	0321523	0321524
Axial deflection	[mm]	16	16	16	16
Angular deflection	[°]	±8	±8	±8	±8
Deflection rotatory	[°]	±20	±20	±20	±20
Min. triggering moment, angular Mx, My	[Nm]	440	549	722	766
Min. triggering torque, rotatory Mz	[Nm]	282	337.2	392	448
Spring triggering force	[N]		767	1534	2301
Spring release torque, angular	[Nm]		109	217	326
Spring release torque, rotatory	[Nm]		55.2	110	166
Supply voltage	[V]	10/30	10/30	10/30	10/30
Repeat accuracy	[mm]	±0.025	±0.025	±0.025	±0.025
Responsiveness	[mm]	0.5	0.5	0.5	0.5
Repeat accuracy, rotary	[min]	5	5	5	5
Min./nom./max. operating pressure	[bar]	1.4/-/6.2	1.4/-/5.9	1.4/-/5.5	1.4/-/5.2
Weight	[kg]	11.4	11.7	11.7	11.7
Min./max. ambient temperature	[°C]	5/60	5/60	5/60	5/60
Dimensions Ø D x Z	[mm]	220 x 118.1	220 x 118.1	220 x 118.1	220 x 118.1
Options and their characteristics					
Splash-proof version		OPR-221-P00-S	OPR-221-P05-S	OPR-221-P10-S	OPR-221-P15-S
ID		0321525	0321526	0321527	0321528
IP protection class		65	65	65	65

Main view

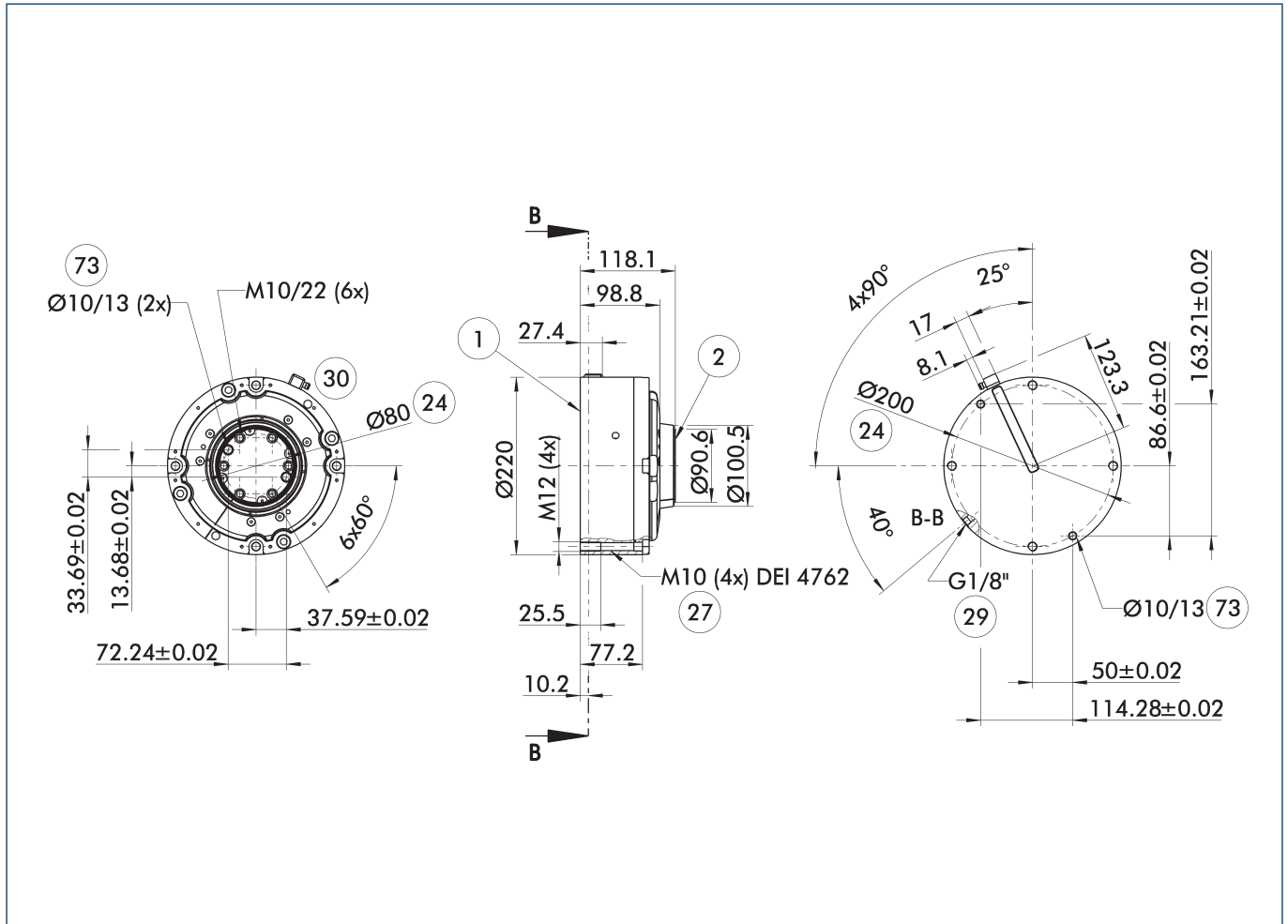

The main view shows the unit in its basic version.

- ① Robot-side connection
- ② Tool-side connection
- ②④ Bolt circle
- ②⑦ Through holes for screw connections
- ②⑨ Air connection P
- ③⑩ Cable connector in enclosed pack with 5 m connection cable
- ⑦⑩ Fit for centering pins

Moment loading

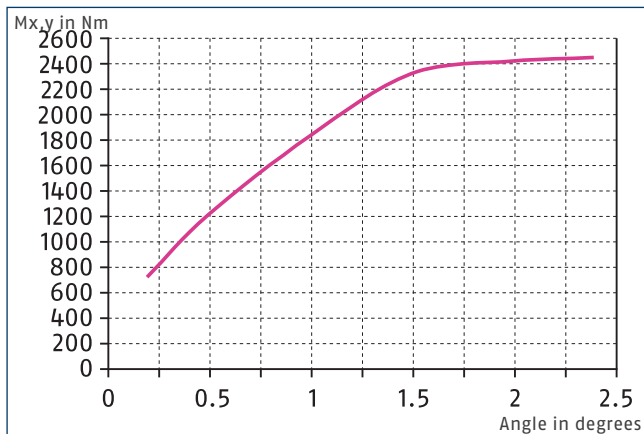

The diagram shows the angular deflection of the OPR according to the moment M_x , M_y with maximum permissible operating pressure.

OPR 221

Anti-collision and overload protection sensor

Adapter plate ISO 9409-A160-R

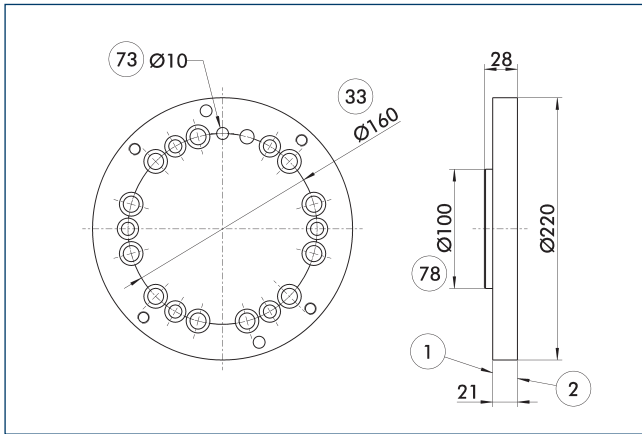

- ① Robot-side connection
- ② Tool-side connection
- ③ DIN ISO-9409 bolt circle
- ⑦③ Fit for centering pins
- ⑦⑧ Fit for centering

Robot-side adapter plate to mount the OPR to a mounting pattern according to ISO 9409-160-6-M10.

Description	ID
Robot side	
A-OPR-221-ISO-A160-plus-IRB6600	0321530

Adapter plate ISO 9409-A200-R

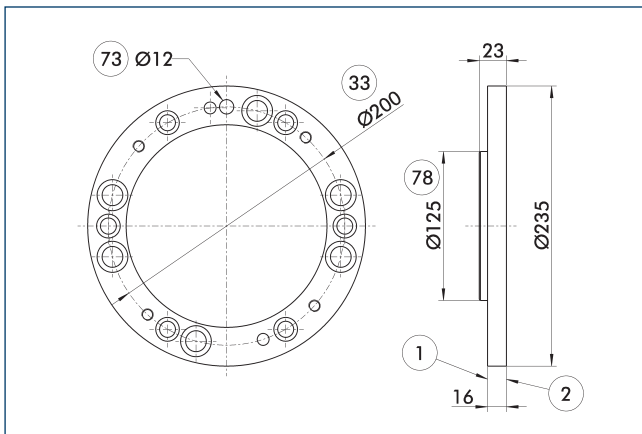

- ① Robot-side connection
- ② Tool-side connection
- ③ DIN ISO-9409 bolt circle
- ⑦③ Fit for centering pins
- ⑦⑧ Fit for centering

Robot-side adapter plate to mount the OPR to a mounting pattern according to ISO 9409-200-6-M10.

Description	ID
Robot side	
A-OPR-221-ISO-A200-plus-IRB7600	0321531

Adapter plate ISO 9409-A160-T

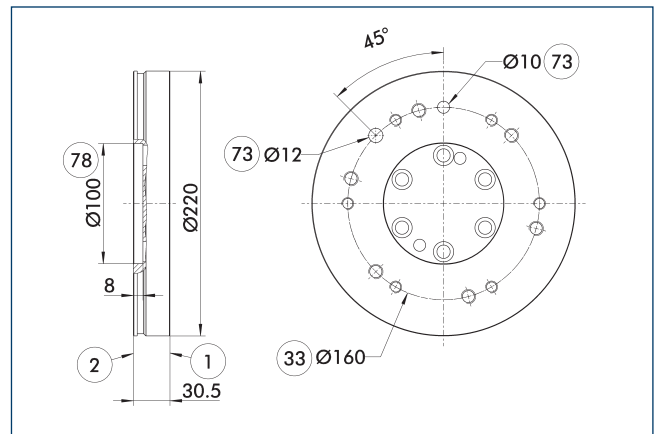

- ① Robot-side connection
- ② Tool-side connection
- ③ DIN ISO-9409 bolt circle
- ⑦③ Fit for centering pins
- ⑦⑧ Fit for centering

Tool-side adapter plate with ISO-9409 screw connection diagram.

Description	ID
Tool side	
A-OPR-221-ISO-A160-T	0321532

Adapter plate ISO 9409-A200-T

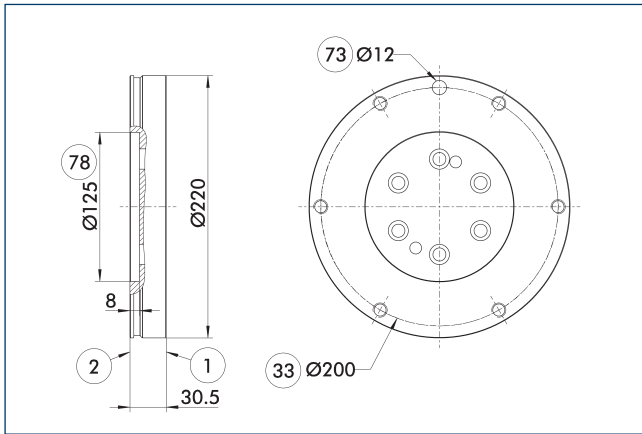

- ① Robot-side connection
- ② Tool-side connection
- ③ DIN ISO-9409 bolt circle
- ⑦③ Fit for centering pins
- ⑦⑧ Fit for centering

Tool-side adapter plate with ISO 9409 screw connection pattern.

Description	ID
Tool side	
A-OPR-221-ISO-A200-T	0321533

Adapter plate BLANK-T

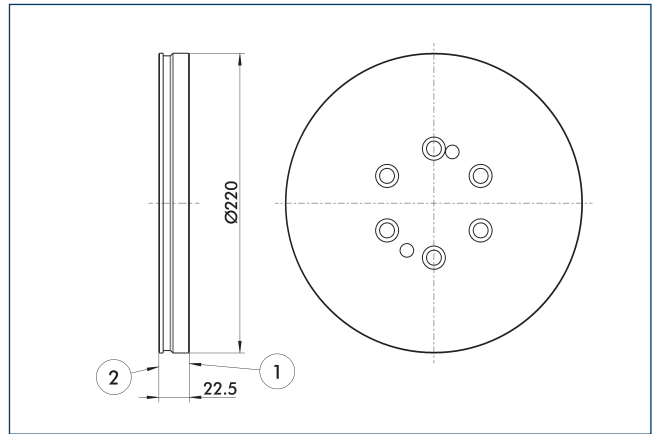

- ① Robot-side connection
- ② Tool-side connection

Unfinished tool-side adapter to be machined by the customer.

Description	ID
Tool side	
A-OPR-221-BLANK-T	0321534

Protection cover OPR-221

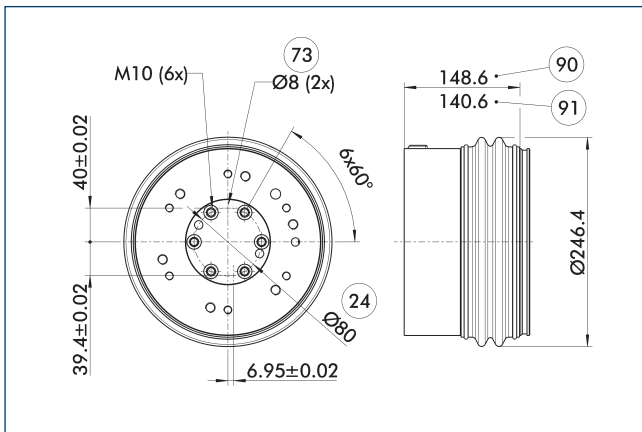

- ②④ Bolt circle
- ⑦③ Fit for centering pins
- ⑨① Total height with adapter plate without flange pattern
- ⑨① Total height with adapter plate with flange pattern according to ISO 9409-A160/A200

The protection boot protects the OPR against coolants for use up to IP 65.

Description	ID	IP protection class
Protection cover		
OPR-221 Flexboot	0321535	65

- ① Please note that when using the protection boot a tool side adapter plate is also needed.

Splash-proof version

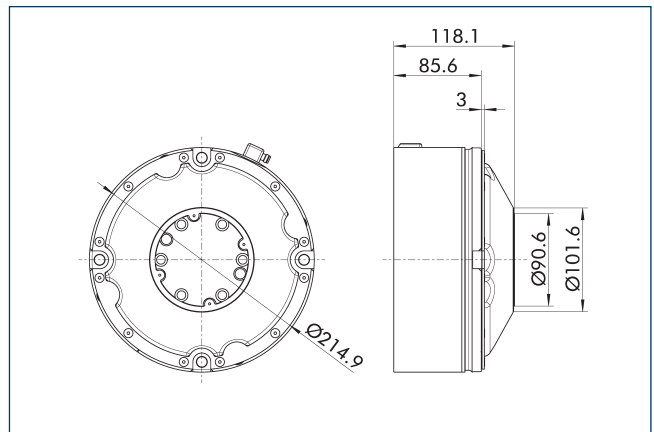

When using the splash water protection version, please be aware of the differences compared to the basic version.



SCHUNK GmbH & Co. KG
Spann- und Greiftechnik

Bahnhofstr. 106 - 134
D-74348 Lauffen/Neckar
Tel. +49-7133-103-0
Fax +49-7133-103-2399
info@de.schunk.com
schunk.com

Folgen Sie uns | *Follow us*





Superior Clamping and Gripping



Product Information

Anti-collision and overload protection sensor OPS

OPS

Anti-collision and overload protection sensor

Compliant. Highly responsive. Easy monitoring. Collision and overload sensor OPS

Collision and overload protection with automatic reset for protecting robots and handling units against damage resulting from collisions or overload conditions.

Field of application

Standard solution for all robot applications whereby the robot, the tool or the workpiece are to be protected against greater damages in case of a collision.



Advantages – Your benefits

Triggering force and torque can be adjusted via the operating pressure for optimal protection of your robots and components

Integrated monitoring for signal transmission without delay in case of collisions so that the robot can be stopped immediately

ISO adapter plates as an option for easy assembly to most of robot types without any manufacturing costs/work



Sizes
Quantity: 4



Triggering force F_d
500 .. 7000 N



Trigger moment M_x
7.5 .. 430 Nm



Trigger moment M_y
7.5 .. 430 Nm



Trigger moment M_z
15 .. 450 Nm

Functional description

In case of a collision, the mounting flange will be deflected. This simultaneously actuates a sensor whose signal triggers the system's emergency stop mechanism. After deflection a manual reset of the OPS can be done

and the unit can be returned into its original position.

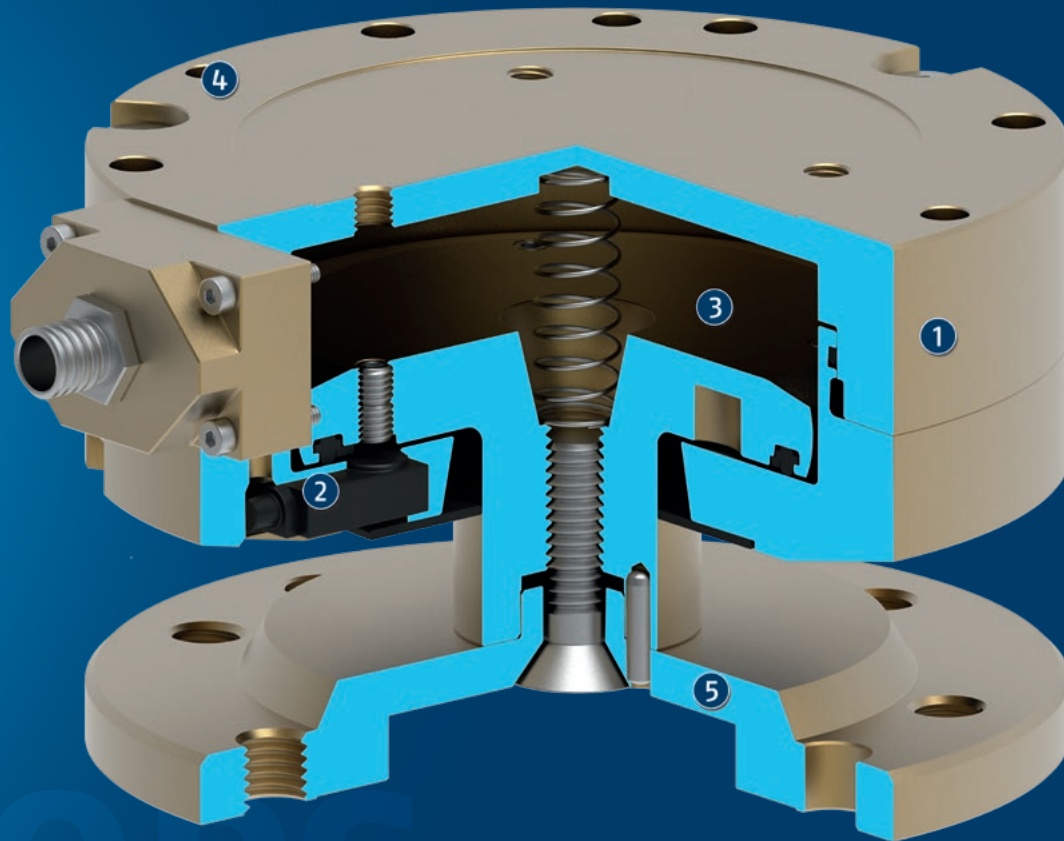

- ① **Housing**
is weight-optimized due to the use of high-strength aluminum alloy
- ② **Sensor system**
for reliable electronic monitoring

- ③ **Pneumatic pistons**
for easy responsiveness by pressure
- ④ **Centering and mounting possibilities**
for easy and fast assembly
- ⑤ **Mounting flange**
deflects in the event of a collision

OPS

Anti-collision and overload protection sensor

General notes about the series

Actuation: pneumatic, with filtered compressed air as per ISO 8573-1:2010 [7:4:4].

Scope of delivery: Angular plug with 5 m cable and open wire strand, operating and maintenance instructions, manufacturer's declaration

Warranty: 24 months

Harsh environmental conditions: Please note that use under harsh environmental conditions (e.g. in the coolant area, cast and grinding dust) can considerably reduce the service life of the units, and we will not take over any warranty. However, in many cases we can find a solution. Please contact us for assistance.

Application example

Assembly unit for intermediate sleeves with various diameters. The unit is equipped with a collision sensor to prevent damages.

- 1 2-finger parallel gripper PFH-mini with workpiece-specific gripper fingers
- 2 Collision sensor OPS

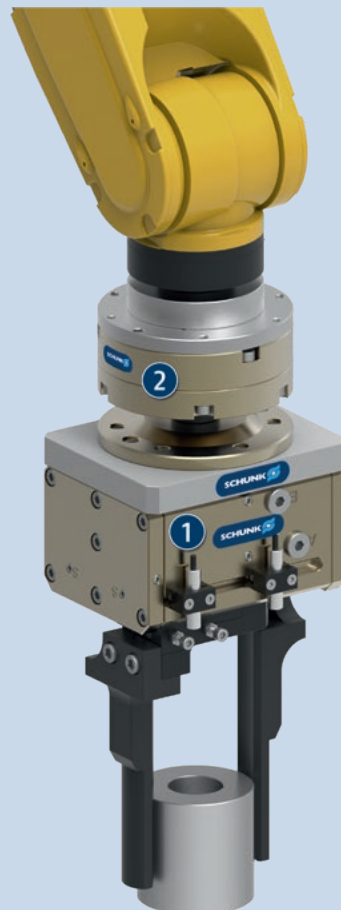

SCHUNK offers more ...

The following components make the product even more productive – the suitable addition for the highest functionality, flexibility, reliability, and controlled production.



Quick change system



Manual change system



Rotary feed-through



Universal gripper



Universal gripper



Angular gripper

① For more information on these products can be found on the following product pages or at schunk.com.

Options and special information

Anti-twist protection: The VS variant limits the rotational deflection to $\pm 45^\circ$.

OPS 080

Anti-collision and overload protection sensor



Triggering torque Mx, My, Mz

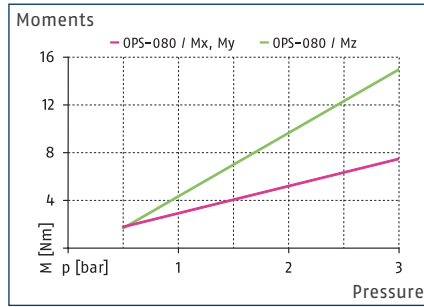

Triggering force Fd

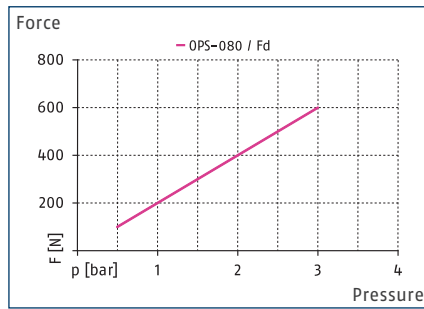

Dimensions and maximum loads

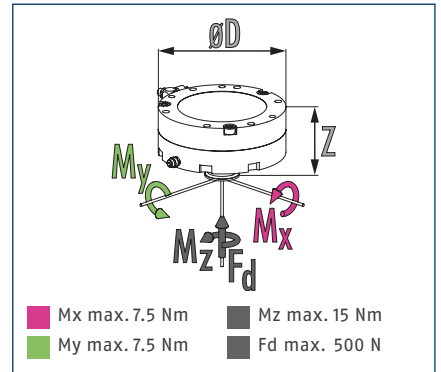

① The design of a collision sensor is defined by the occurring forces and moments in your application.

Technical data

Description		OPS-080
ID		0321125
Axial deflection	[mm]	12
Angular deflection	[°]	±12
Deflection rotatory	[°]	±360
Min. triggering moment, angular Mx, My	[Nm]	2
Supply voltage	[V]	10/30
Repeat accuracy	[mm]	±0.02
Responsiveness	[mm]	0.1
Repeat accuracy, rotary	[min]	5
Min./nom./max. operating pressure	[bar]	0.5/-/3
Weight	[kg]	0.4
Min./max. ambient temperature	[°C]	5/60
Dimensions Ø D x Z	[mm]	80 x 56

Main view

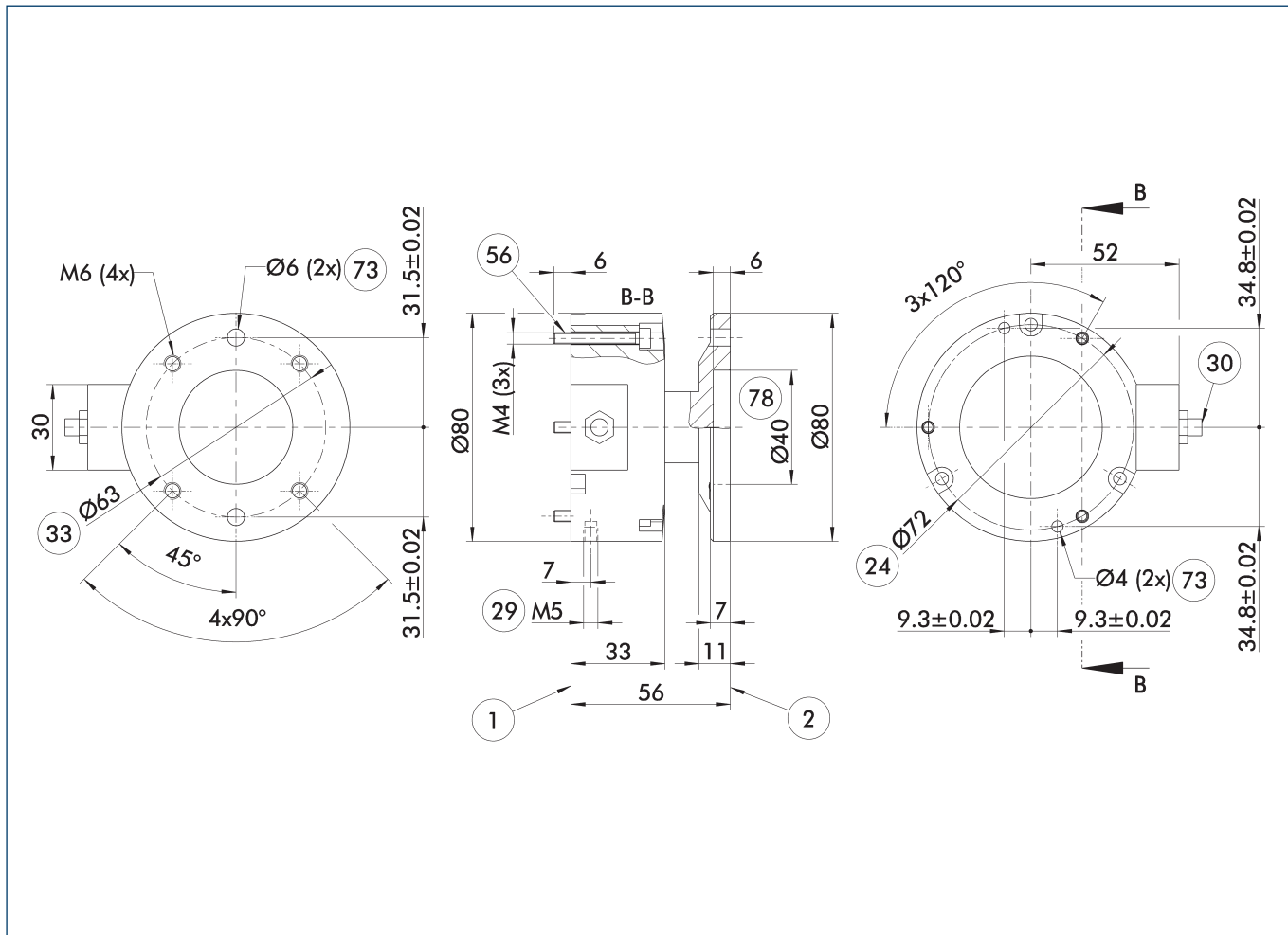

The main view shows the unit in its basic version.

- ① Robot-side connection
- ② Tool-side connection
- ②④ Bolt circle
- ②⑨ Air connection P
- ③⑩ Cable connector in enclosed pack with 5 m connection cable
- ③③ DIN ISO-9409 bolt circle
- ⑤⑥ Included in the scope of delivery
- ⑦③ Fit for centering pins
- ⑦⑧ Fit for centering

OPS 080

Anti-collision and overload protection sensor

Adapter plate ISO 9409-A50-R

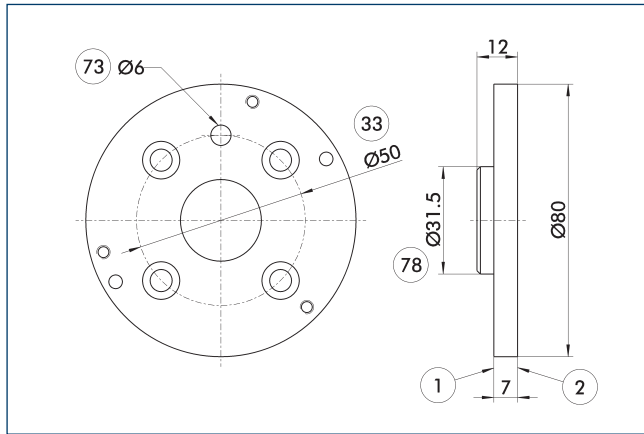

- ① Robot-side connection
- ② Tool-side connection
- ③ DIN ISO-9409 bolt circle
- ⑦③ Fit for centering pins
- ⑦⑧ Fit for centering

Robot-side adapter plate to mount the OPS to a mounting pattern according to ISO 9409-50-4-M6.

Description	ID
Robot side	
A-OPS-080-ISO-A50-R	0321114

Adapter plate ISO 9409-A63-R

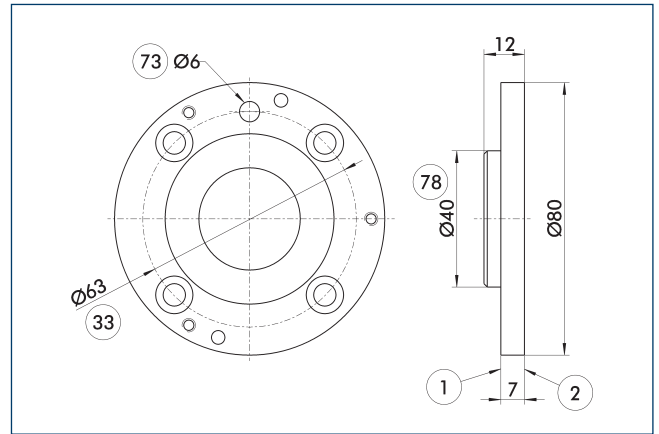

- ① Robot-side connection
- ② Tool-side connection
- ③ DIN ISO-9409 bolt circle
- ⑦③ Fit for centering pins
- ⑦⑧ Fit for centering

Robot-side adapter plate to mount the OPS to a mounting pattern according to ISO 9409-63-4-M6.

Description	ID
Robot side	
A-OPS-080-ISO-A63-R	0321115

OPS 100

Anti-collision and overload protection sensor



Triggering torque Mx, My, Mz

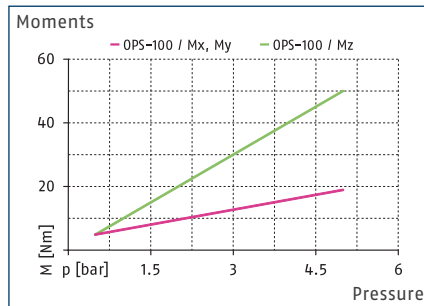

Triggering force Fd

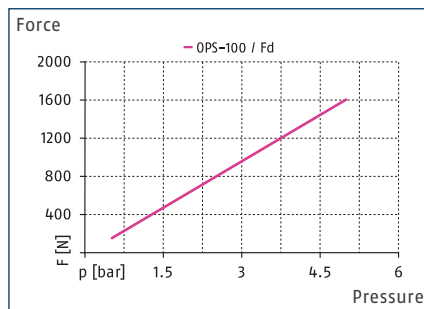

Dimensions and maximum loads

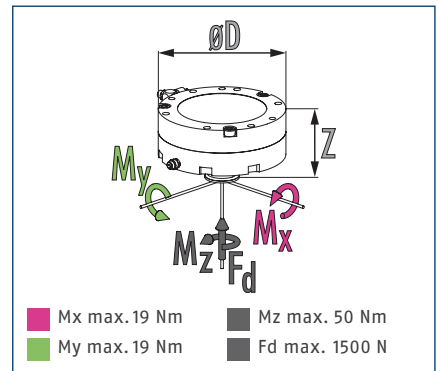

① The design of a collision sensor is defined by the occurring forces and moments in your application.

Technical data

Description		OPS-100
ID		0321130
Axial deflection	[mm]	14
Angular deflection	[°]	±12
Deflection rotatory	[°]	±360
Min. triggering moment, angular Mx, My	[Nm]	5
Supply voltage	[V]	10/30
Repeat accuracy	[mm]	±0.02
Responsiveness	[mm]	0.1
Repeat accuracy, rotary	[min]	5
Min./nom./max. operating pressure	[bar]	0.5/-/5
Weight	[kg]	0.7
Min./max. ambient temperature	[°C]	5/60
Dimensions Ø D x Z	[mm]	100 x 63

Main view

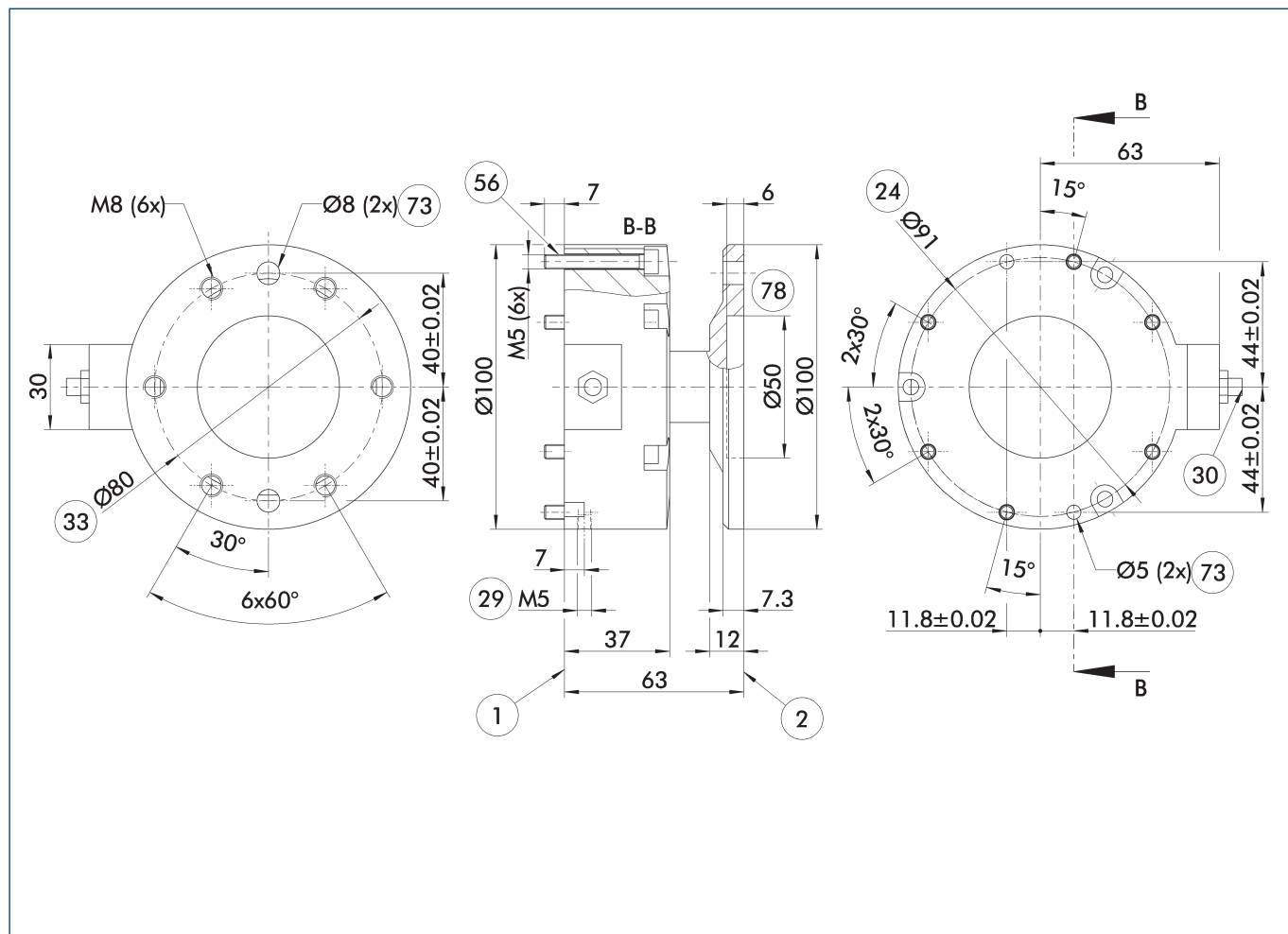

The main view shows the unit in its basic version.

- ① Robot-side connection
- ② Tool-side connection
- ③ DIN ISO-9409 bolt circle
- ④ Bolt circle
- ⑤ Air connection P
- ⑥ Cable connector in enclosed pack with 5 m connection cable
- ⑦ Included in the scope of delivery
- ⑧ Fit for centering pins
- ⑨ Fit for centering

OPS 100

Anti-collision and overload protection sensor

Adapter plate ISO 9409-A50-R

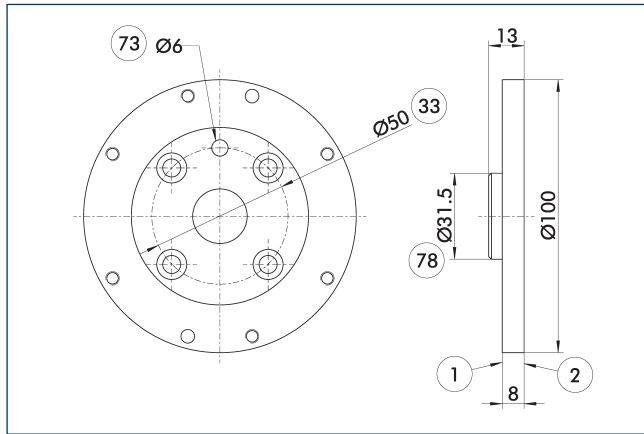

- ① Robot-side connection
- ② Tool-side connection
- ③③ DIN ISO-9409 bolt circle
- ⑦③ Fit for centering pins
- ⑦⑧ Fit for centering

Robot-side adapter plate to mount the OPS to a mounting pattern according to ISO 9409-50-4-M6.

Description	ID	
Robot side		
A-OPS-100-ISO-A50-R	0321122	

Adapter plate ISO 9409-A63-R

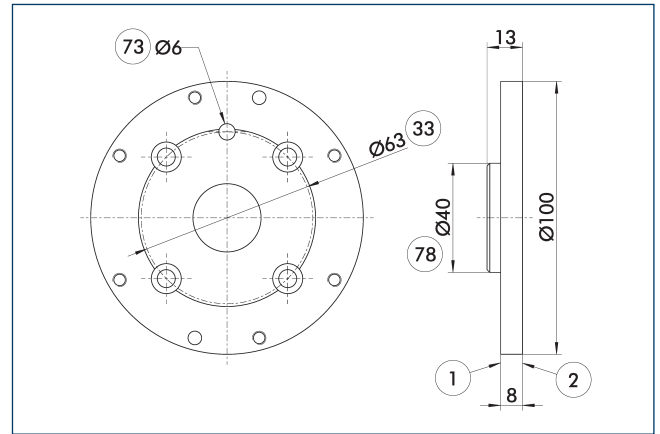

- ① Robot-side connection
- ② Tool-side connection
- ③③ DIN ISO-9409 bolt circle
- ⑦③ Fit for centering pins
- ⑦⑧ Fit for centering

Robot-side adapter plate to mount the OPS to a mounting pattern according to ISO 9409-63-4-M6.

Description	ID	
Robot side		
A-OPS-100-ISO-A63-R	0321123	

Adapter plate ISO 9409-A80-R

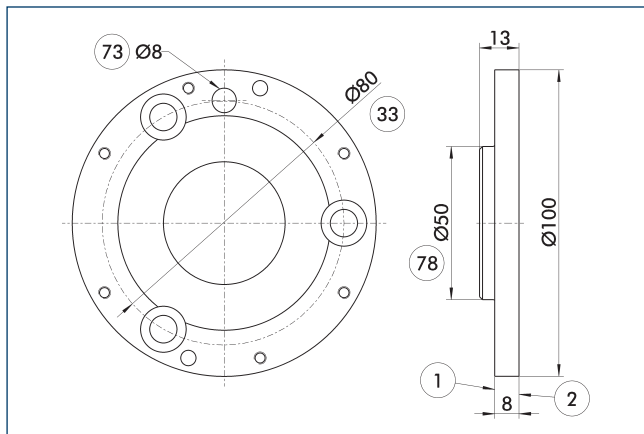

- ① Robot-side connection
- ② Tool-side connection
- ③③ DIN ISO-9409 bolt circle
- ⑦③ Fit for centering pins
- ⑦⑧ Fit for centering

Robot-side adapter plate to mount the OPS to a mounting pattern according to ISO 9409-80-6-M8.

Description	ID	
Robot side		
A-OPS-100-ISO-A80-R	0321116	

OPS 160

Anti-collision and overload protection sensor



Triggering torque Mx, My, Mz

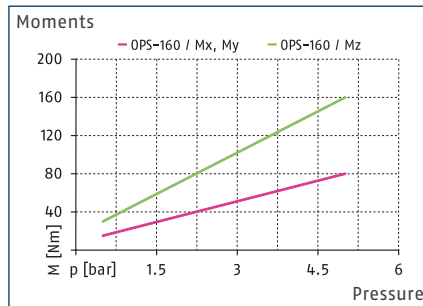

Triggering force Fd

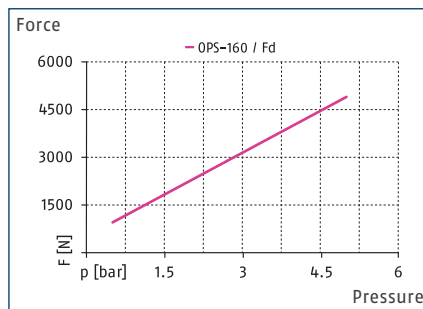

Dimensions and maximum loads

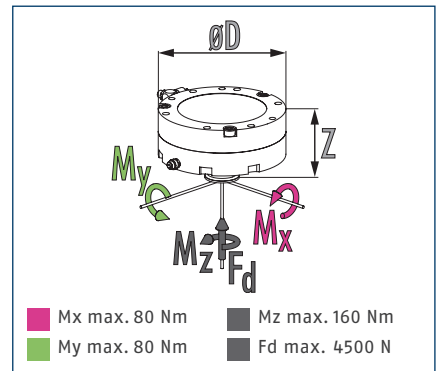

① The design of a collision sensor is defined by the occurring forces and moments in your application.

Technical data

Description		OPS-160
ID		0321135
Axial deflection	[mm]	8
Angular deflection	[°]	±5
Deflection rotatory	[°]	±360
Min. triggering moment, angular Mx, My	[Nm]	30
Supply voltage	[V]	10/30
Repeat accuracy	[mm]	±0.02
Responsiveness	[mm]	0.2
Repeat accuracy, rotary	[min]	5
Min./nom./max. operating pressure	[bar]	0.5/-/5
Weight	[kg]	4.3
Min./max. ambient temperature	[°C]	5/60
Dimensions Ø D x Z	[mm]	160 x 79

Main view

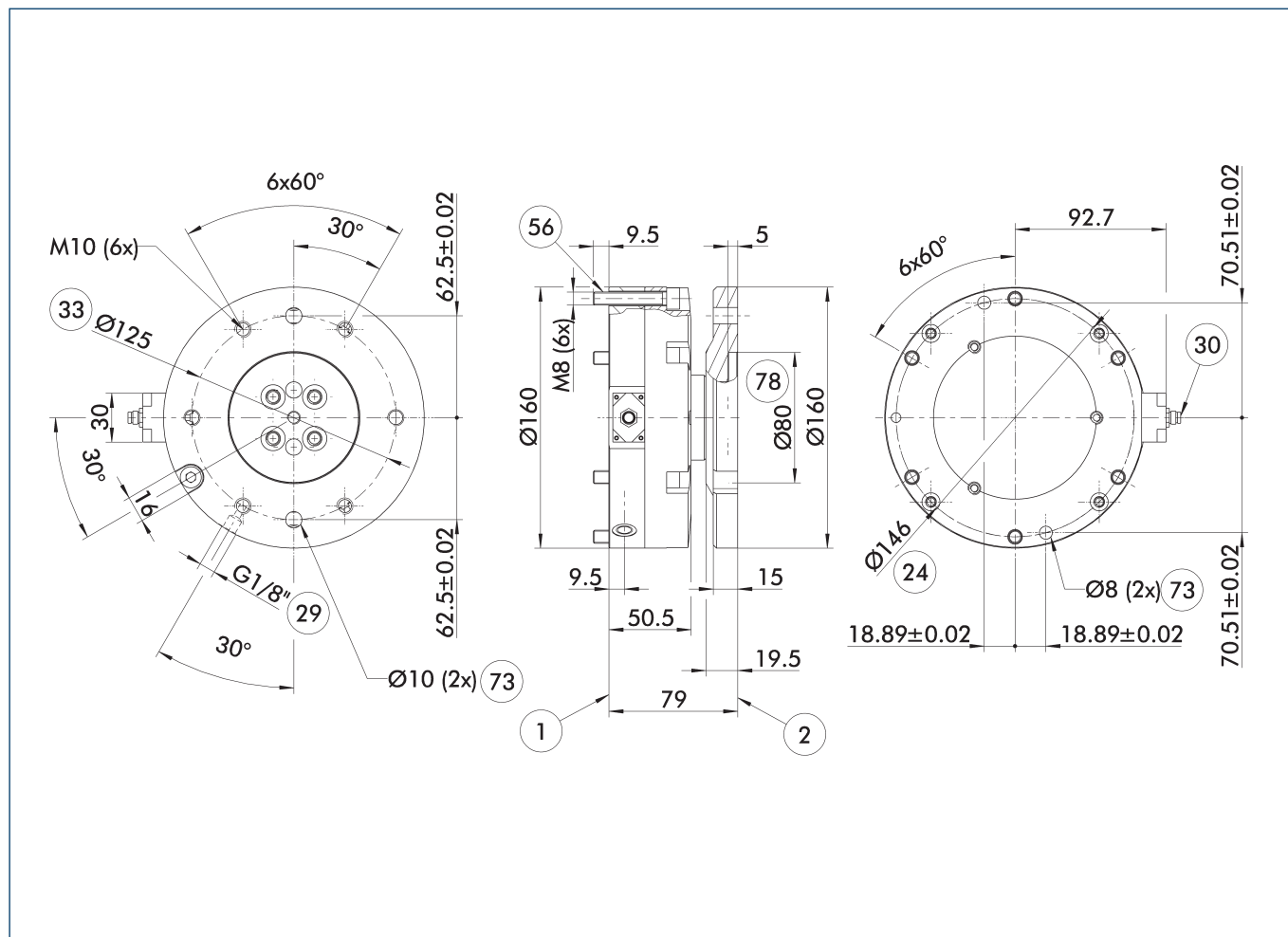

The main view shows the unit in its basic version.

- ① Robot-side connection
- ② Tool-side connection
- ②④ Bolt circle
- ②⑨ Air connection P
- ③⑩ Cable connector in enclosed pack with 5 m connection cable
- ③③ DIN ISO-9409 bolt circle
- ⑤⑥ Included in the scope of delivery
- ⑦③ Fit for centering pins
- ⑦⑧ Fit for centering

OPS 160

Anti-collision and overload protection sensor

Adapter plate ISO 9409-A100-R

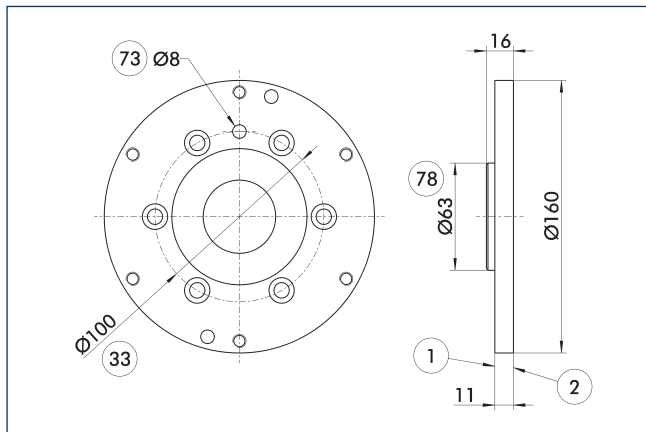

- ① Robot-side connection
- ② Tool-side connection
- ③ DIN ISO-9409 bolt circle
- ⑦③ Fit for centering pins
- ⑦⑧ Fit for centering

Robot-side adapter plate to mount the OPS to a mounting pattern according to ISO 9409-100-6-M8.

Description	ID
Robot side	
A-OPS-160-ISO-A100-R	0321224

Adapter plate ISO 9409-A125-R

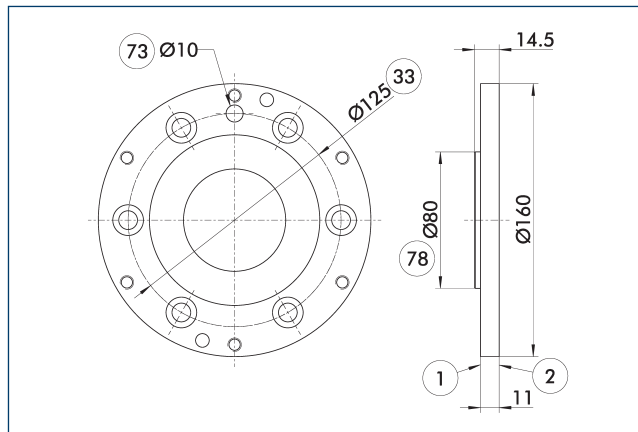

- ① Robot-side connection
- ② Tool-side connection
- ③ DIN ISO-9409 bolt circle
- ⑦③ Fit for centering pins
- ⑦⑧ Fit for centering

Robot-side adapter plate to mount the OPS to a mounting pattern according to ISO 9409-125-6-M10.

Description	ID
Robot side	
A-OPS-160-ISO-A125-R	0321117

OPS 200

Anti-collision and overload protection sensor



Triggering torque Mx, My, Mz

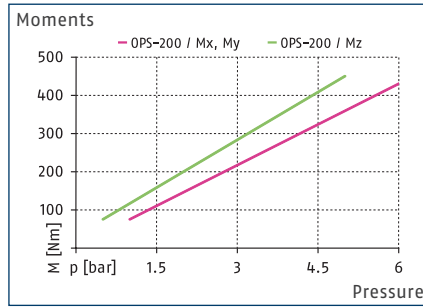

Triggering force Fd

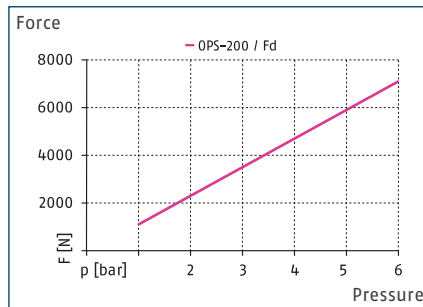

Dimensions and maximum loads

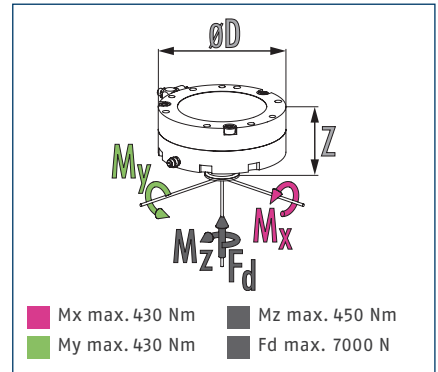

ⓘ The design of a collision sensor is defined by the occurring forces and moments in your application.

Technical data

Description		OPS-200	OPS-200-VS
ID		0321140	0321141
Axial deflection	[mm]	9.5	9.5
Angular deflection	[°]	±4	±4
Deflection rotatory	[°]	±360	45
Min. triggering moment, angular Mx, My	[Nm]	90	90
Supply voltage	[V]	10/30	10/30
Repeat accuracy	[mm]	±0.05	±0.05
Responsiveness	[mm]	0.3	0.3
Repeat accuracy, rotary	[min]	5	5
Min./nom./max. operating pressure	[bar]	1/-/6	1/-/6
Weight	[kg]	7	7
Min./max. ambient temperature	[°C]	5/60	5/60
Dimensions Ø D x Z	[mm]	200 x 90	200 x 90

Main view

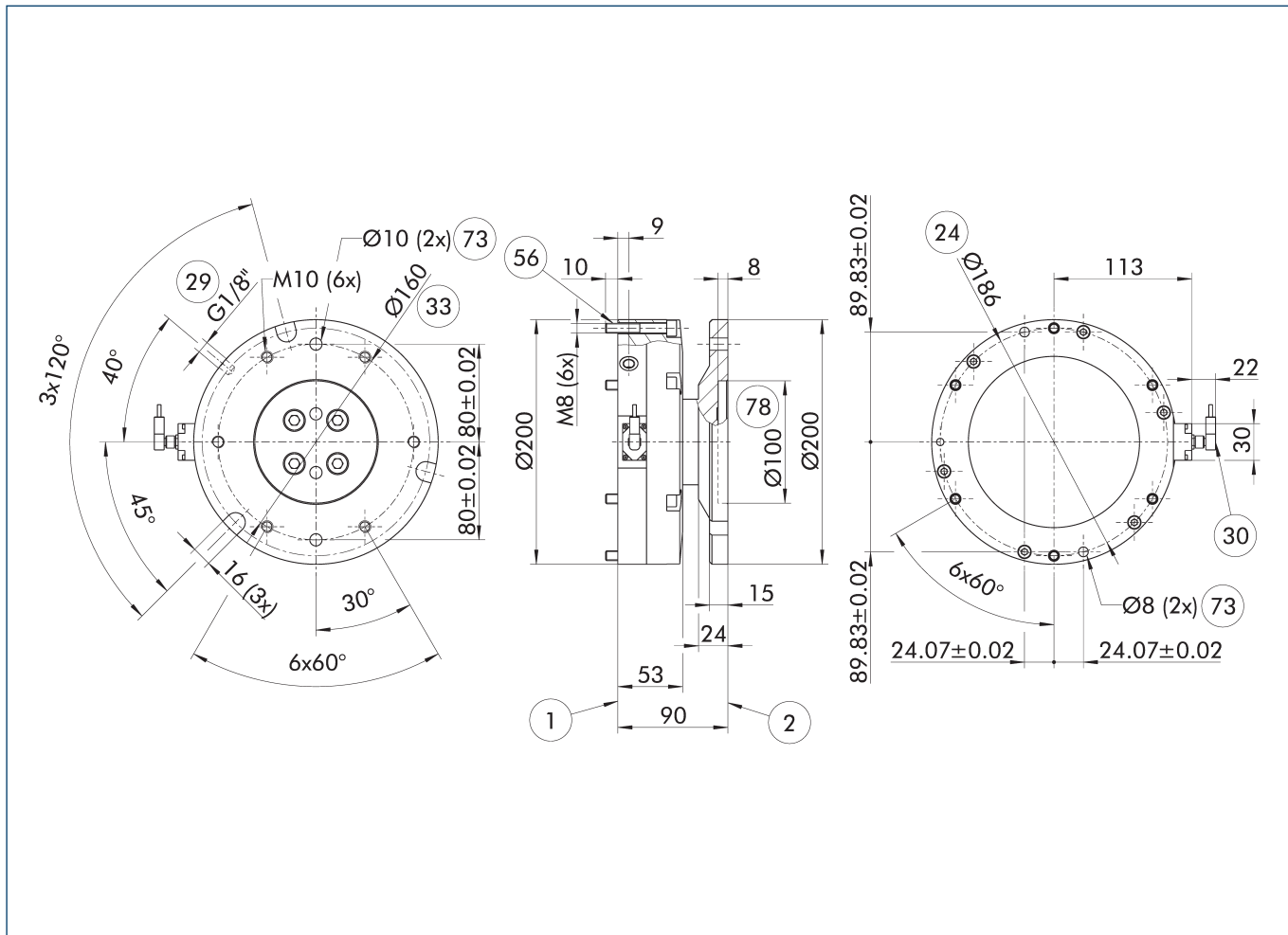

The main view shows the unit in its basic version.

- | | |
|---|--------------------------------------|
| ① Robot-side connection | ③③ DIN ISO-9409 bolt circle |
| ② Tool-side connection | ⑤⑥ Included in the scope of delivery |
| ②④ Bolt circle | ⑦③ Fit for centering pins |
| ②⑨ Air connection P | ⑦⑧ Fit for centering |
| ③⑩ Cable connector in enclosed pack with 5 m connection cable | |

OPS 200

Anti-collision and overload protection sensor

Adapter plate ISO 9409-A125-R

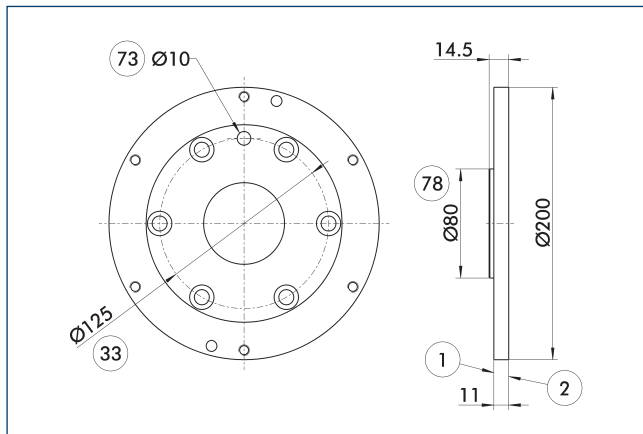

- ① Robot-side connection
- ② Tool-side connection
- ③③ DIN ISO-9409 bolt circle
- ⑦③ Fit for centering pins
- ⑦⑧ Fit for centering

Robot-side adapter plate to mount the OPS to a mounting pattern according to ISO 9409-125-6-M10.

Description	ID
Robot side	
A-OPS-200-ISO-A125-R	0321126

Adapter plate ISO 9409-A160-R

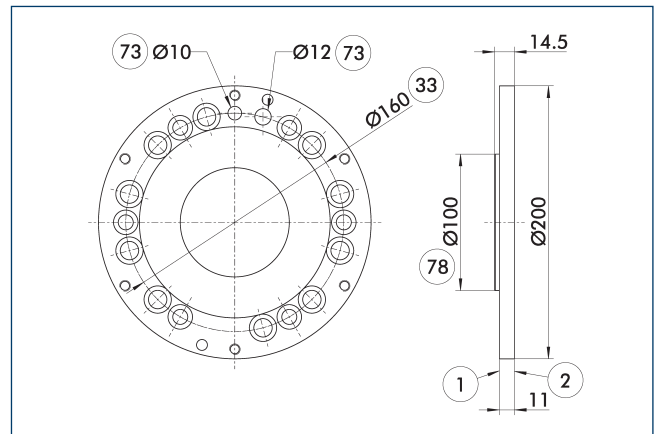

- ① Robot-side connection
- ② Tool-side connection
- ③③ DIN ISO-9409 bolt circle
- ⑦③ Fit for centering pins
- ⑦⑧ Fit for centering

Robot-side adapter plate to mount the OPS to a mounting pattern according to ISO 9409-160-6-M10 and ISO 9409-160-10-M12.

Description	ID
Robot side	
A-OPS-200-ISO-A160-R	0321118



SCHUNK GmbH & Co. KG
Spann- und Greiftechnik

Bahnhofstr. 106 - 134
D-74348 Lauffen/Neckar
Tel. +49-7133-103-0
Fax +49-7133-103-2399
info@de.schunk.com
schunk.com

Folgen Sie uns | *Follow us*

