

## COMPANY AND PRODUCTS

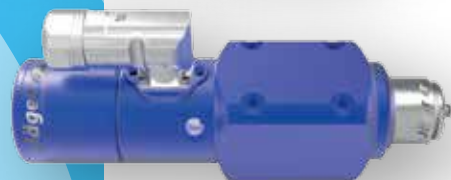

# DOWNLOAD OUR APP



## VISIT OUR WEBSITE

# WWW.ALFREDJAEGER.DE



# WWW

# CONTENT

<b>JÄGER QUALITY</b>	<b>06</b>
<b>PRODUCTION</b>	<b>07</b>
<b>Z-LINE</b>	<b>08</b>
<b>F-LINE</b>	<b>14</b>
<b>SK-LINE</b>	<b>16</b>
<b>POWER-LINE</b>	<b>18</b>
<b>CHOPPER</b>	<b>20</b>
<b>DRESSING SYSTEMS</b>	<b>22</b>
<b>DENTADRIVE</b>	<b>24</b>
<b>ALFRED JÄGER ON YOUTUBE</b>	<b>25</b>
<b>APPLICATIONS</b>	<b>26</b>
<b>SERVICE</b>	<b>31</b>
<b>REPAIRS</b>	<b>32</b>
<b>ON-SITE CONSULTATION</b>	<b>33</b>
<b>ACCESSORIES</b>	<b>34</b>

A photograph of a man in a grey suit and blue tie holding a white brochure with the 'Jäger' logo. He is standing at a trade show booth, with a woman in a dark suit seen from behind in the foreground. The background is slightly blurred, showing other booth elements like a sign with 'A52' and a rainbow flag.

*“ If there is any one secret of success, it lies in the ability to get the other person's point of view and see things from that person's angle as well as from your own. ”*

Henry Ford

The specifications, dimensions and materials used in this catalogue represent our current products. We reserve the right to change and further develop the products shown.

The performance data for our high-frequency spindles is dependent on the frequency converter used and may deviate from the specified values. Great care was taken in preparing and

compiling the specifications in this catalogue. Alfred Jäger GmbH cannot, however, accept any legal responsibility or liability for any incorrect information or the consequences thereof.

# COMMITTED EMPLOYEES HIGH-PRECISION PRODUCTS

With its extensive range of high-frequency spindles and high-performance equipment, Jäger High Performance Spindles ensures a solution for high-precision machining tasks.

## HIGH-PERFORMANCE TECHNOLOGY

Development, production and assembly are all carried out completely in-house. In this way, we ensure our products are of the highest technical standard and simultaneously ensure the shortest possible production and delivery periods.

We, now already over 100 Alfred Jäger GmbH employees. We have stood for innovation and tradition in global machine tool manufacture for over 40 years:

these main focuses have made our company, which is now already managed by the second generation, one of the world's leaders in the manufacture of high-frequency spindles. Our products provide top quality when milling, engraving, drilling and grinding the most varied materials.

"It's not quality if it's not a Jäger spindle" – this is what our long-standing customers report. We want to continue to live up to these positive experiences and even improve on them. That's why we strive to improve day after day. For our customers. For you.

Our forward-looking management team and our expert committed employees ensure that development potential is consistently used to continually improve our products, for a flexible, customer-oriented company structure and, last but not least, for excellent service and a comprehensive consulting service.

These factors have ensured that we have an outstanding position on the global market. In this brochure, we would like to introduce our company and products to you and convince you of our services.

"If it's not Jäger, it's not quality" – that's what our customers say.

Maybe you will be one of them soon!

## BEST QUALITY

Guaranteed by 100 employees at any time and proven by our long-standing satisfied customers.



*For more than 40 years we have been developing, producing, and distributing high-frequency spindles for milling, engraving, drilling and grinding of manifold materials for the most varied markets throughout the world.*

Bernd Jäger  
Managing Director

A handwritten signature in black ink, appearing to read 'B. Jäger'.

# QUALITY

- ✓ DIN EN ISO 9001:2008
- ✓ DIN EN ISO 14001:2004
- ✓ BS OHSAS 18001:2007



## ONLY THE BEST IS GOOD ENOUGH

The highest quality of our products also guarantees the highest satisfaction of our customers. We don't make any compromises. Stability, safety, the best materials and constant quality checks make us a reliable partner for innovative spindle systems.

We use hybrid precision ball bearings as standard in our Jäger high-frequency spindles. Their rings are made of steel and their balls of ceramic.

The ceramic ball material is the best choice for use in high-precision ball bearings.

Advantages of hybrid precision ball bearings:

- ✓ Longer service life
- ✓ Low friction coefficient
- ✓ Higher speeds
- ✓ Low heat conductivity
- ✓ Corrosion resistant
- ✓ Non-magnetic
- ✓ Electrically isolating
- ✓ Higher rigidity of bearing arrangement
- ✓ Low vibration impulse by ceramic balls

However, this alone is not enough to provide you with truly the highest quality. The Jäger high-frequency spindles have further important benefits:

- ✓ Bearings lubricated for life
- ✓ High stiffness because of special bearing arrangement
- ✓ High run-out accuracy
- ✓ Air sealing to prevent dirt entering
- ✓ Operating hours counter
- ✓ Tool monitoring
- ✓ Low vibration through fine balancing of individual parts
- ✓ Quality control after every production step
- ✓ Internal coolant supply (optional)
- ✓ Vector control and sensors (optional)
- ✓ Minimum quantity lubrication (optional)



## MADE IN GERMANY

Germany as a location for mechanical engineering represents top quality. For this reason, our products are developed, produced and assembled completely in-house.

Even the motors are either developed and built by us or we work with our certified suppliers. Here in Germany, we have expert employees, the best material and we can give you an excellent on-site service here. Development, production and service – everything from a single source. This is the only way that we can check and guarantee the high quality standard of our products – for your benefit. Our production currently already takes place in three factories, with over 100 employees. Our global exports are increasing all the time.

Because quality has a name: Made in Germany





# Z-LINE

- ✓ Cylindrical spindles with three different tool change systems
- ✓ Manual tool change
- ✓ Pneumatic direct change
- ✓ Pneumatic taper change (WK/BT/HSK/ISO)
- ✓ Rated speed of up to 100,000 rpm

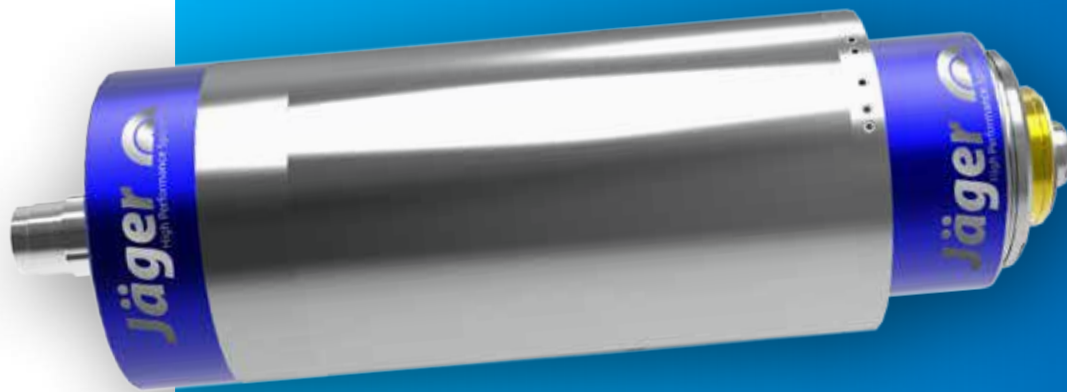

## Z-LINE

The different tool change systems make the "Jäger high-frequency spindles" a universal instrument for high-precision machining, from milling to drilling, grinding to engraving.

### VIEW DATA SHEETS ONLINE











Scan this  
QR code using  
the Jäger app  
or any  
QR code scanner



Of course, automatic change systems increase the processing speed and thereby the economic efficiency of a production process. However, sometimes it is necessary or desirable to carry out the tool change manually. The respective tool used is changed by hand using pressure collets or traction collets in the Z-spindle.



# MANUAL TOOL CHANGE

Spindle-Type	Ceramic hybrid ball bearing (pcs)	Steel ball bearing (pcs)	Rated power [kW] S1-100% (S6-60%)	Frequency [Hz]	Motor poles (pairs)	Rated rotation speed [rpm]	Housing diameter [mm]	Liquid cooled	Clamping range up to [mm]	Tool holder / Collet type	Weight [~kg]
 Z33-M060.05 S1 PNC 10200031	2	1	0.18 (0.24)	1 000	1	60 000	33		3.5	5,5H	0.5
 Z33-M060.10 K2S15 PNC 10200039	2	1	0.18 (0.24)	1 000	1	60 000	33		4.5	ER8	0.6
 Z42-M160.20 S5 PNC 10201024	2		0.3 (0.5)	1 000	1	60 000	42		7	ER11	0.9
 Z45-M160.02 S5 PNC 10201036	3		0.46 (0.63)	1 000	1	60 000	45		7	ER11	1.5
 Z62-M260.23 S5 PNC 10202024	2		0.67 (0.83)	1 000	1	60 000	62		7	ER11	3
 Z62-M360.56 S5 PNC 10203044	4		1.2 (1.4)	1 000	1	60 000	62	✓	10	ER16	2.7
 Z80-M445.06 S5 PNC 10204044	3		2.6 (3.1)	1 500	2	45 000	62 80	✓	10	HSK-C25	4.2
 Z80-M450.60 S5 PNC 10204048	3		2.7 (3.4)	1 667	2	50 000	80	✓	10	ER16	4.6
 Z80-M530.05 S5 PNC 10205009	4		4.6 (5.2)	1 000	2	30 000	80	✓	13	HSK-C32	8
 Z100-M536.03 S5 PNC 10205020	4		5.5 (8.0)	1 200	2	36 000	80 100	✓	16	HSK-C40	11.6

For more standard spindles, check online.  
Special spindles are available any time on request.

# Z-LINE

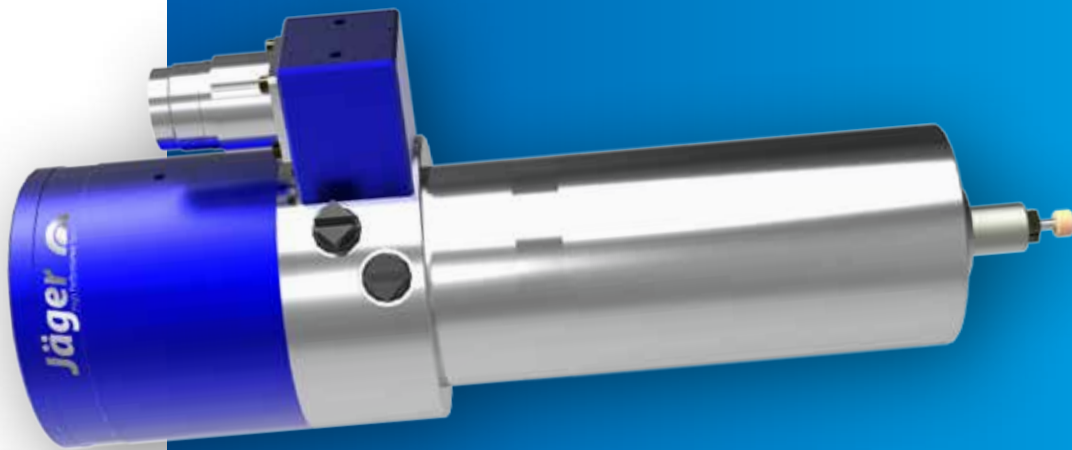

## Z-LINE

The "Jäger high-frequency spindles" are sophisticated products with the highest precision, stability and running smoothness. Constant development and ongoing quality checks guarantee the performance required for high-precision machining tasks.

Our Z-spindles are cylindrical spindles with a short spindle length which are fitted with an asynchronous motor (a synchronous motor is also available depending on requirements) and hybrid precision ball bearings (for the highest possible run-out accuracy) as standard. Using air sealing inside spindles prevents dust, chippings and liquids entering, significantly increasing the service life. Other advantages include the high stiffness, the low vibration running and the bearings lubricated for life.









### VIEW DATA SHEETS

#### ONLINE

Scan this  
QR code using  
the Jäger app  
or any  
QR code scanner

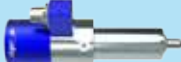

# PNEUMATIC DIRECT CHANGE

Spindle-Type		Ceramic hybrid ball bearing (pcs)	Steel ball bearing (pcs)	Rated power [kW] S1-100% (S6-60%)	Frequency [Hz]	Motor poles (pairs)	Rated rotation speed [rpm]	Housing diameter [mm]	Liquid cooled	ESD protection / Contact by touch	Taper cleaning	Clamping range up to [mm]	Collet type	Weight [-kg]
	Z33-D060.02 S2A PNC 10300017		2	0.18 (0.24)	1 000	1	60 000	33		✓		3	5,1P-5°	1.1
	Z33-D1100.02 S2AY PNC 10301078	2		0.3 (0.5)	1 667	1	100 000	33		✓		3	5,1P-5°	1.1
	Z42-D160.19 S3A PNC 10301083	2		0.3 (0.5)	1 000	1	60 000	42		✓		6	8/5°	2.2
	Z45-D160.02 S3 PNC 10301067	3		0.46 (0.63)	1 000	1	60 000	45				6	8/5°	3.2
	Z45-D160.03 S3 PNC 10301091	3		0.46 (0.63)	1 000	1	60 000	45			✓	6	8/5°	3.2
	Z62-D260.02 S2A PNC 10302176	2		0.9 (1)	2 000	2	60 000	62		✓		6	8/5°	3.3
	Z62-D360.53 S5AM PNC 10303037	3		1.2 (1.4)	1 000	1	60 000	62	✓	✓	✓	6	8/5°	4
	KS2-10/80-2 IP PNC 10302082	3		0.9 (1.1)	1 333	1	80 000	62	✓	✓		6	8/5°	4.2

For more standard spindles, check online.  
Special spindles are available any time on request.

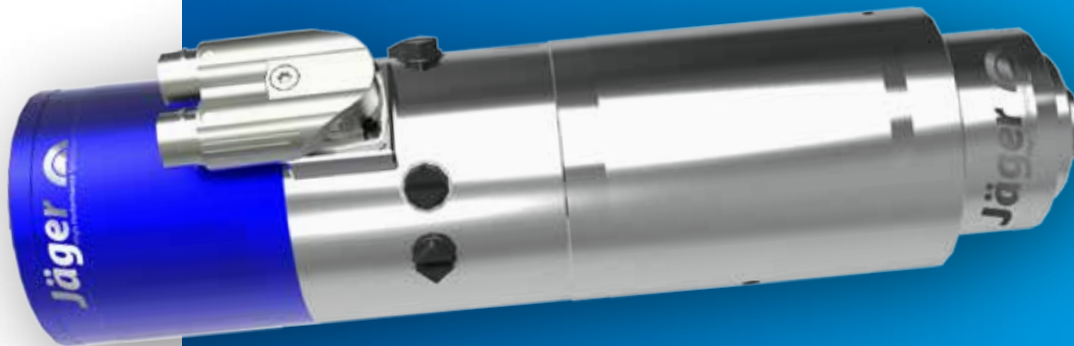

## Z-LINE WITH PNEUMATIC TAPER CHANGE

The whole workflow is made significantly more efficient if the tools are changed automatically. Processing can take place without interruption, thereby increasing the facility's productivity enormously.

### VIEW DATA SHEETS ONLINE

Scan this  
QR code using  
the Jaeger app  
or any  
QR code scanner









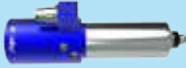

Tool mounting is carried out using a taper adapter in this change variant for the "Jaeger high-frequency spindle". Individual solutions are of course possible as desired and needed. The following options are available for the taper change system:

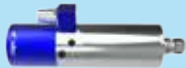
- ✓ WK tool mount taper
- ✓ WK shrinking mount taper
- ✓ HSK tool taper
- ✓ BT tool taper
- ✓ ISO tool taper

Regardless of which variant you choose, the "Jaeger high-frequency spindles" always guarantee the best quality, speed and precision.

# PNEUMATIC TAPER CHANGE (WK/BT/HSK)

Spindle-Type		Ceramic hybrid ball bearing (pcs)	Rated power [kW] S1-100% (S6-60%)	Fre-quency [Hz]	Motor poles (pairs)	Rated rota-tion speed [rpm]	Housing diameter [mm]	Liquid cooled	ESD protection / Contact by touch	Tool change monitoring	Vector control	Eddy current sensor	Internal coolant supply	Clamping range up to [mm]	Tool holder	Weight [-kg]
	Z62-K360.12 S5 PNC 10403025	2	1.2 (1.4)	1 000	1	60 000	62	✓						6	WK16	4
	Z62-K360.40 S5AM PNC 10403126	4	1.2 (1.4)	1 000	1	60 000	62	✓	✓					6	WK16	4
	Z80-K450.03 S5 PNC 10404231	4	1.8 (2.1)	1 667	2	50 000	80	✓						10	WK19	6
	Z80-K530.02 S6W2 PNC 10405011	4	4.6 (5.2)	1 000	2	30 000	80	✓		✓				16	WK25	10
	Z80-H536.08 S8RVW3 PNC 10405047	4	4.7 (5.1)	1 200	2	36 000	80	✓		✓	✓	✓	✓	13	HSK-E32	12
	Z80-H445.06 S19W2/2 PNC 10404066	3	2.6 (3.1)	1 500	2	45 000	80	✓		✓				10	HSK-E25	6
	Z80-H450.03 S5W2 PNC 10404040	2	1.8 (2.1)	1 667	2	50 000	80	✓		✓				10	HSK-E25	6
	Z100-H530.05 S11W2 PNC 10405044	4	5.5 (8)	1 000	2	30 000	100	✓		✓				16	HSK-E40	15
	Z100-H540.08 S3W2 PNC 10405013	4	5.5 (8)	1 333	2	40 000	100	✓		✓				13	HSK-E32	14

For more standard spindles, check online.  
Special spindles are available any time on request.

# F-LINE

- ✓ High-frequency machine spindles for high-speed milling, drilling, grinding and engraving
- ✓ Customised spindle flange
- ✓ Rated power from 5.5 to 27 kW
- ✓ Rated speed of up to 50,000 rpm

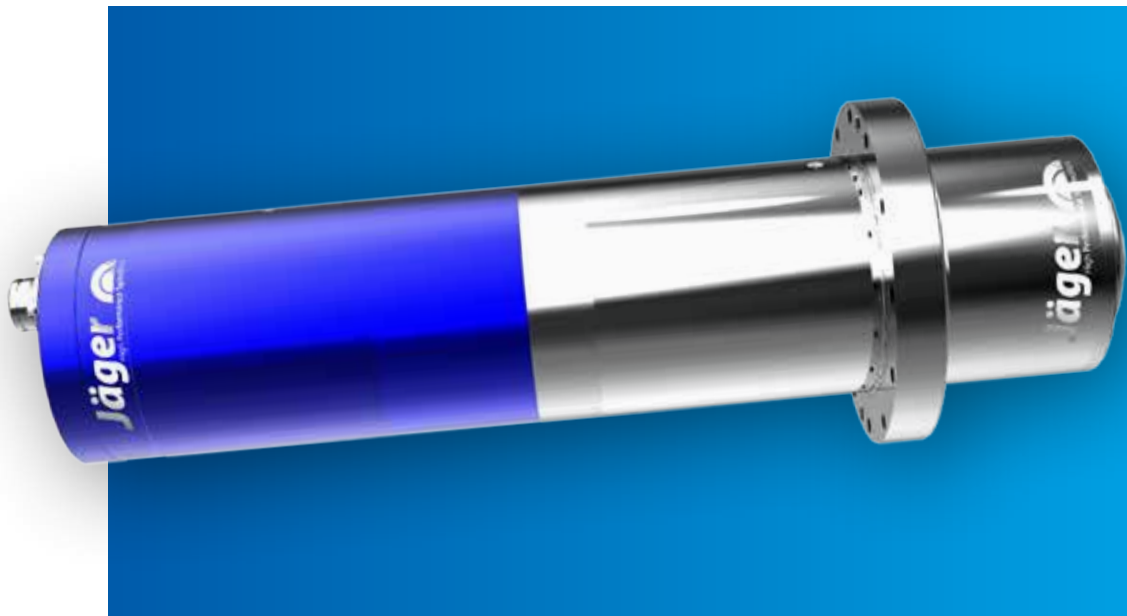

## F-LINE





The "Jäger F-spindles" have a spindle flange for attachment. This flange is produced in accordance with your requirements and gives your machine even more stability.

### VIEW DATA SHEETS ONLINE

Scan this  
QR code using  
the Jäger app  
or any  
QR code scanner



Each of our F-spindles can be delivered with an individually customised spindle flange. Of course, the F-spindles also work with different tool change systems. Manual change is equally as possible as pneumatic taper change (WK/BT/HSK).

Spindle-Type	Ceramic hybrid ball bearing (pcs)	Rated power [kW] S1-100% (S6-60%)	Frequency [Hz]	Motor poles (pairs)	Rated rotation speed [rpm]	Housing diameter [mm] (Flange diameter)	Liquid cooled	Tool change	Tool change monitoring	Vector control	Eddy current sensor	Internal coolant supply	Clamping range up to [mm]	Tool holder	Weight [~kg]
 F80-M530.05 K02S5R PNC 10205019	4	4.6 (5.2)	1 000	2	30 000	80 (98)	✓	☞				✓	13	HSK-C32	8
 F100-H536.01 S11W2 PNC 10405060	4	5.5 (8)	1 200	2	36 000	100 (144)	✓	▽	✓	*		*	16	HSK-E40 ( HSK-E32)	16
 F120-H830.02 S9W2V PNC 10408010	4	16.6 (19)	1 000	2	30 000	120 (144)	✓	▽	✓	✓		*	20	HSK-E50	26
 F140-H830.04 S11W3RV PNC 10408014	4	16.6 (19)	1 000	2	30 000	140 (164)	✓	▽	✓	✓	✓	✓	20	HSK-E50	40
 F150-H930.02 K1RVW3 PNC 10409002	4	26.8 (37)	1 000	2	30 000	150 (194)	✓	▼	✓	✓		✓	20	HSK-E50	50

- ☞ Manual clamping
- Pneumatic direct tool change
- ▽ Pneumatic taper change
- ▼ Hydraulic taper change
- \* Optional

For more standard spindles, check online.  
Special spindles are available any time on request.



# SK-LINE

- ✓ Short taper spindles for manual or automatic replacement in the tool machine
- ✓ Manual tool change: tool mounting takes place using pressure collets or manual HSK
- ✓ Automatic tool change: tool mounting takes place using WK tool mount tapers, WK shrinking mount tapers or HSK tool tapers

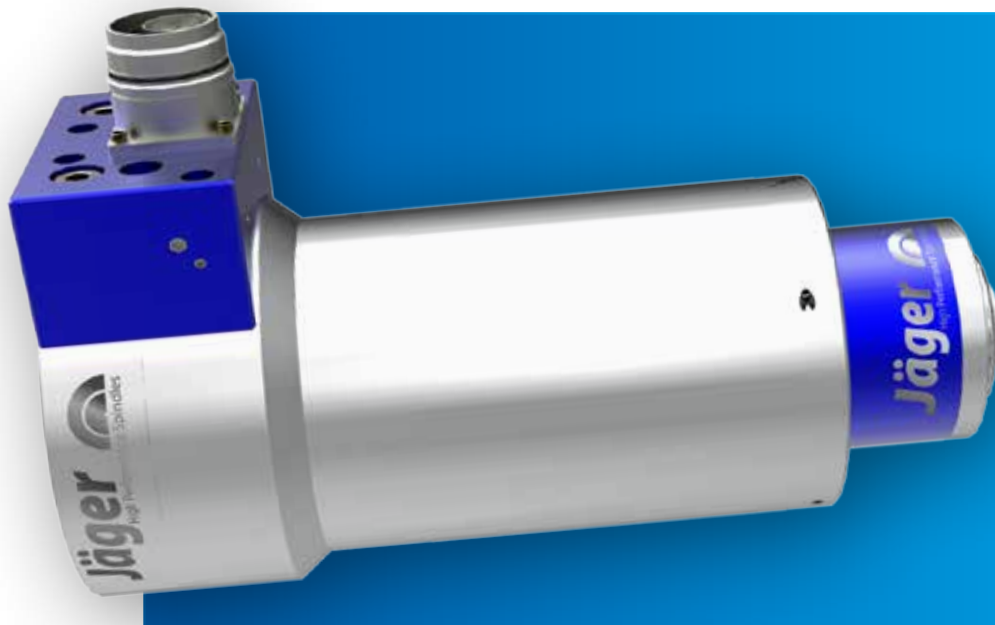

## SK-LINE

"Jaeger SK-spindles" are spindles with short taper adapters for manual or automatic replacement in the main drive of the tool machine. They increase the speed range of your tool machine and enable fast cutting rates.

### VIEW DATA SHEETS ONLINE

Scan this  
QR code using  
the Jaeger app  
or any  
QR code scanner















Of course, the "Jaeger SK-spindles" can be delivered with different tool change systems, for example with manual or pneumatic taper change (WK/HSK). The SK-spindle is mounted on the tool machine using a taper adapter.

Possible adapter versions: SK, BT, HSK and specialised customer mounts.

#### Additional facts:

- ✓ Rated power: from 0.3 to 11 kW
- ✓ Rated speed: up to 80,000 rpm

Spindle-Type		Ceramic hybrid ball bearing (pcs)	Rated power [kW] S1-100% (S6-60%)	Frequency [Hz]	Motor poles (pairs)	Rated rotation speed [rpm]	Synchronous technology	Housing diameter [mm]	Liquid cooled	Tool change	Tool change monitoring	Minimum quantity lubrication	Clamping range up to [mm]	Tool holder / Collet type	Weight (without taper) [~ kg]
	S62-M360.06 S5 PNC 10503007	2	1.2 (1.4)	1 000	1	60 000		62	✓	✎			8	ER16	3.6
	S80-M450.34 S5 PNC 10504070	3	2.7 (3.4)	1 667	2	50 000		80	✓	✎			10	HSK-C25	5.5
	S80-M450.43 S5 PNC 10504166	3	2.7 (3.4)	1 667	2	50 000		80	✓	✎			10	ER16	5.5
	S120-M530.22 S5 PNC 10505114	4	4.4 (5.4)	1 000	2	30 000		120	✓	✎			16	HSK-C40	15
	SP120-M630.22 S5 PNC 13506114	4	7 (9)	1 000	2	30 000	✓	120	✓	✎			16	HSK-C40	15
	S120-H630.26 S8W2 PNC 10806105	4	7 (9)	1 000	2	30 000		120	✓	▽	✓	*	16	HSK-E40	26
	S120-H642.21 S8W2 PNC 10806100	4	7 (9)	1 400	2	42 000		120	✓	▽	✓	*	13	HSK-E32	19
	SP120-H642.21 S8W2 PNC 13806000	4	7 (9)	1 400	2	42 000	✓	120	✓	▽	✓	*	13	HSK-E32	18
	SP120-H730.26 S8W2 PNC 13807005	4	11 (14)	1 000	2	30 000	✓	120	✓	▽	✓		16	HSK-E40	26

-  Manual clamping
-  Pneumatic taper change
-  Optional

For more standard spindles, check online.  
Special spindles are available any time on request.

# POWER-LINE

- ✓ More output with the same housing diameter
- ✓ Partial saving of coolant
- ✓ Higher torque
- ✓ Cooler shafts
- ✓ Stiffer bearing system
- ✓ Brushless synchronous motors with sensor-free drive



## POWER-LINE

A strong motor for high performance. Sensor-free driven, extremely high performance, brushless synchronous motors: These are the Jäger Power-Line spindles.





Synchronous motor technology allows for significantly higher output compared with asynchronous motors. Depending on the scale, it can even be possible to double output. The use of extremely strong permanent magnets in the motor also allows the realization of larger shaft diameters and therefore stiffer bearing systems. Here is how you use Power-Line's strength:

- ✓ More output with the same housing size
- ✓ Or a smaller housing with the same output
- ✓ Partial saving of coolant due to cooler shafts
- ✓ Stiffer bearing system

### VIEW DATA SHEETS ONLINE

Scan this  
QR code using  
the Jäger app  
or any  
QR code scanner



Spindle-Type	Ceramic hybrid ball bearing (pcs)	Steel ball bearing (pcs)	Rated power [kW] S1-100% (S6-60%)	Frequency [Hz]	Motor poles (pairs)	Rated rotation speed [rpm]	Housing diameter [mm]	Liquid cooled	ESD protection / Contact by touch	Taper cleaning	Tool change	Tool change monitoring	Clamping range up to [mm]	Tool holder / Collet type	Weight [~kg]
 ZS33-D060.55 K1AR PNC 13301015		3	0.38 (0.52)	1000	1	60 000	33		✓	✓	☐		3	5,1P-5°	1
 ZS62-D360.51 S5AM PNC 13303034	3		1.8 (2.1)	1000	1	60 000	62	✓	✓	✓	☐		6	8/5°	4
 ZS62-D460.01 S5AM PNC 13304001	3		1.8 (2.1)	1000	1	60 000	62	✓	✓	✓	☐		8	10/5°	5
 ZS80-H445.06 S19W2/2 PNC 13404066	3		3.7 (4.8)	1500	2	45 000	62 80	✓			▽	✓	10	HSK-E25	6

-  Manual clamping
- ☐ Pneumatic direct tool change
- ▽ Pneumatic taper change

For more standard spindles, check online.  
Special spindles are available any time on request.

# CHOPPER

- ✓ Attractive price
- ✓ Various tool clamping systems in one basic body
- ✓ No costs for an external cooling unit as the Chopper spindles are air-cooled
- ✓ The Chopper series is also offered as a bundle

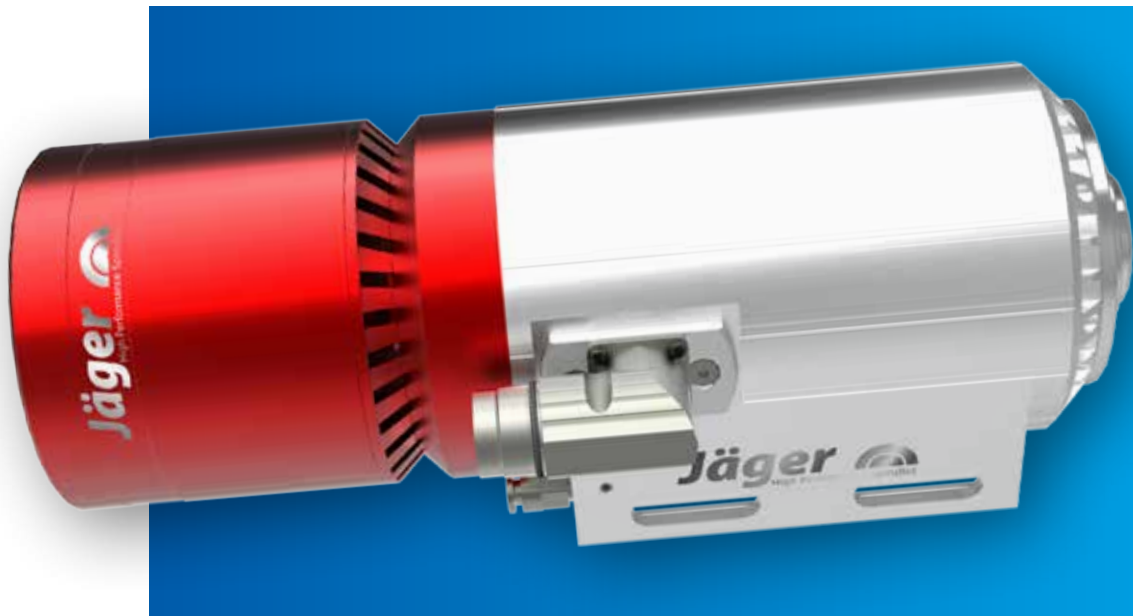

## CHOPPER





You can save on everything except quality. That's why Jäger GmbH developed the "Chopper series" of their high-frequency spindles.



The "Chopper series" is a well-thought-out spindle concept which integrates the various tool clamping systems in just one basic module. Manual change, pneumatic direct change and taper change are all possible. The ventilation system which is integrated into the spindle also saves the costs for an external cooling unit. Saving production costs was the focus when developing the Chopper series, but of course without forfeiting the quality. The result is a fully-fledged product for a low price.

### VIEW DATA SHEETS ONLINE

Scan this  
QR code using  
the Jäger app  
or any  
QR code scanner



Spindle-Type	Ceramic hybrid ball bearing (pcs)	Steel ball bearing (pcs)	Rated power [kW] S1-100% (S6-60%)	Frequency [Hz]	Motor poles (pairs)	Rated rotation speed [rpm]	Housing diameter [mm]	Cooling system	ESD protection / Contact by touch	Tool change	Tool change monitoring	Clamping range up to [mm]	Tool holder / Collet type	Weight [~kg]
 Chopper 1500 H S5A PNC 11203002		2	1.5 (1.9)	500	1	30 000	100		<input checked="" type="checkbox"/>			10	ER16	6
 Chopper 1500 D PNC 11303001		2	1.5 (1.9)	500	1	30 000	100			<input type="checkbox"/>		8	10/5°	7
 Chopper 1500 K S5A PNC 11403004		2	1.5 (1.9)	500	1	30 000	100		<input checked="" type="checkbox"/>	<input type="checkbox"/>		10	WK19	7
 Chopper 1500 HSK S5A PNC 11503005		2	1.5 (1.9)	500	1	30 000	100		<input checked="" type="checkbox"/>	<input type="checkbox"/>		10	HSK-E25	7
 Chopper 2300-40 K S5A PNC 11403003	2		2.3 (2.6)	667	1	40 000	100		<input checked="" type="checkbox"/>	<input type="checkbox"/>	<input checked="" type="checkbox"/>	10	WK19	7
 Chopper 2300-40 HSK S5 PNC 11503003	2		2.3 (2.6)	667	1	40 000	100			<input type="checkbox"/>	<input checked="" type="checkbox"/>	10	HSK-E25	7
 Chopper 3300 H S5 PNC 11205005		3	3.3 (4.5)	500	1	30 000	100					16	ER25	7.4
 Chopper 3300 HSK S5A PNC 11505003		3	3.3 (4.5)	500	1	30 000	100		<input checked="" type="checkbox"/>	<input type="checkbox"/>		13	HSK-E32	9.4
 Chopper 5000 HSK S5 PNC 11505001		3	5 (6.5)	500	1	30 000	100			<input type="checkbox"/>	<input checked="" type="checkbox"/>	13	HSK-E32	9.4
 Chopper 6500 HSK PNC 11507001	4		5 (6.5)	800	2	24 000	142			<input type="checkbox"/>	<input checked="" type="checkbox"/>	20	HSK-F63	27

-  Air cooled
-  Liquid cooled
-  Manual clamping
- Pneumatic direct tool change
- Pneumatic taper change

For more standard spindles, check online.  
Special spindles are available any time on request.

# DRESSING SYSTEMS

- ✓ Higher accuracy
- ✓ Flawless grinding
- ✓ Touch recognition possible

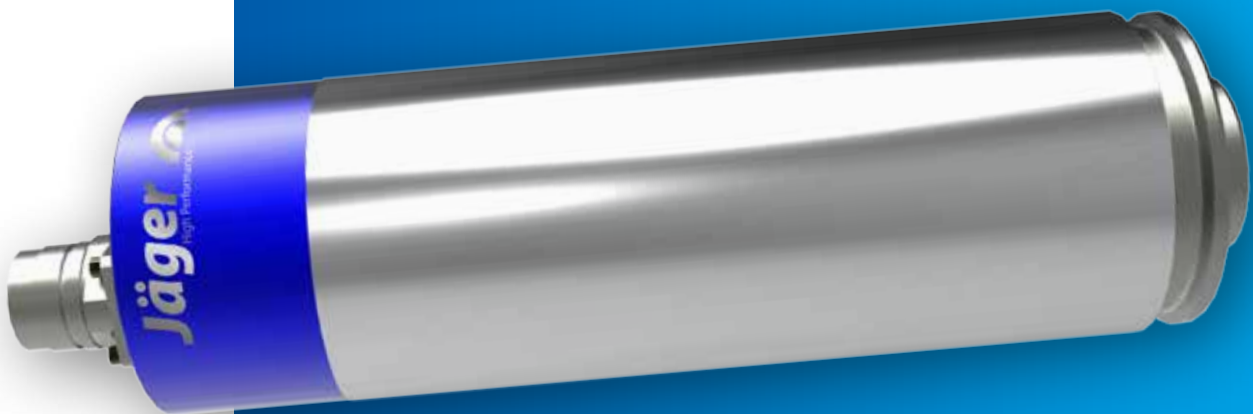

## DRESSING SYSTEMS

Consistent quality is important when grinding. Abrasive wear and distortion can, however, lead to faults. The grinding wheels must be dressed at regular intervals for this reason. In addition to this, they must be dressed to suit the geometry of each new work piece.

### VIEW DATA SHEETS

#### ONLINE

Scan this  
QR code using  
the Jäger app  
or any  
QR code scanner



Alfred Jäger GmbH provides all the devices needed for efficient and flawless grinding, from rotating dressing tools (for "soft" dressing) to precise touch recognition. The aligned dressing process makes it possible to influence the grinding process quickly and efficiently. In this way, the grinding quality is always of the highest standard and the production procedure is not interrupted by faults.



### Frequency converter

#### FU 01-03 T7,8



PNC 41510222  
Supply voltage 115...230 V<sub>AC</sub>  
Output power 3 000 VA  
Output current 7.8 A  
Output frequency 8 000 Hz

#### Typ 3



PNC 41510136  
Supply voltage 180...260 V<sub>AC</sub>  
Output power 4 000 VA  
Output current 10 A  
Output frequency 1 600 Hz

#### FU 07-00T 08A60



PNC 41510171  
Supply voltage 115...230 V<sub>AC</sub>  
Output power 250 VA  
Output current electronically limited  
Output frequency 1 000 Hz

#### FU 07-00S 08A60



PNC 41510181  
Supply voltage 115...230 V<sub>AC</sub>  
Output power 250 VA  
Output current electronically limited  
Output frequency 1 000 Hz

### Spindle-Type

#### ARS72-M216.04 S3



PNC 10004012  
Ceramic hybrid ball bearing (pcs) 3  
Rated power 0.5 kW  
Motor poles (pairs) 2  
Rated rotation speed 16 000 rpm  
Housing diameter 72 mm

#### ARS72-M216.04 S3 E



PNC 10004013  
Ceramic hybrid ball bearing (pcs) 3  
Rated power 0.5 kW  
Motor poles (pairs) 2  
Rated rotation speed 16 000 rpm  
Housing diameter 72 mm  
Touch recognition AE-Sensor

#### ARS42-M120.02 S2



PNC 10201040  
Ceramic hybrid ball bearing (pcs) 2  
Rated power 0.16 kW  
Motor poles (pairs) 1  
Rated rotation speed 20 000 rpm  
Housing diameter 42 mm

#### ARS33-M060.18 K3S15



PNC 10200043  
Ceramic hybrid ball bearing (pcs) 2  
Rated power 0.18 kW  
Motor poles (pairs) 1  
Rated rotation speed 60 000 rpm  
Housing diameter 33 mm

### Evaluation and control unit

#### Sensiton 6



PNC 41510225  
Supply voltage 24 V<sub>AC</sub>  
Rated power 6 W  
Sensor Input 2 x 3 pin

#### AE6000



PNC 41510226  
Supply voltage 24 V<sub>AC</sub>  
Rated power 12 W  
Sensor Input 4 x 5 pin

# DENTADRIVE

- ✓ High performance for optimum results
- ✓ Well protected for reliable work
- ✓ Whether grinding or milling, always the optimum standard
- ✓ Over 50 different types of spindle



## DENTADRIVE

The DentaDrive range is available in 3 different performance classes with speed ranges up to 60,000, 80,000 and 100,000 rpm. Our modular designs enable you to select between double and triple bearings. Whatever your task requires.

DentaDrive spindles are available in two types of housing - cylinder or block. Both designs have "sealing air" to prevent dirt penetrating the spindle. The DentaDrive series has been consistently developed to meet market requirements. The materials used, the rigidity of the spindle and its protection against contamination makes the DentaDrive equally suitable for wet or dry machining. The high degree to which individual components can be combined opens up a range of over 50 different DentaDrive spindles right from the start. If that's still not enough, our "dental development team" is also available to adapt your individual spindle.

### CONFIGURE YOUR INDIVIDUAL SPINDLE SYSTEM FROM HIGH-PERFORMANCE COMPONENTS!

Scan this  
QR code using  
the Jäger app  
or any  
QR code scanner



# ALFRED JÄGER ON YOUTUBE

- ✓ Get a close-up of our motors
- ✓ Our spindles in action
- ✓ Examples of various applications areas
- ✓ Subscribe to our channel and stay up to date

The YouTube logo is centered in the lower half of the page. It features the word "You" in black and "Tube" in white on a red rounded rectangle, all set against a background of overlapping blue and light blue squares of various sizes and opacities.

## VISIT US AT OUR YOUTUBE CHANNEL

Scan this  
QR code with the  
Jäger app or  
using a QR code  
scanner



## Your Alfred Jäger branches around the world

### China

Alfred Jäger Trading (Beijing) Co., Ltd.

Phone +86 10 8274 3881

Fax +86 10 8274 3886

E-Mail: [baoweima@spindles.asia](mailto:baoweima@spindles.asia)

Web: [www.jaeger-spindle.com.cn](http://www.jaeger-spindle.com.cn)

### Italy

Alfred Jäger GmbH

Phone +39 (0)444 1240080

Fax +49 6002 9123-46

E-Mail: [sales@alfredjaeger.de](mailto:sales@alfredjaeger.de)

Web: [www.alfredjaeger.de](http://www.alfredjaeger.de)

### Japan

Alfred Jäger GmbH

Phone +81-45-620-8853

Fax +81-45-620-8854

E-Mail: [yuichi.sato@spindles.asia](mailto:yuichi.sato@spindles.asia)

Web: [www.alfredjaeger.de](http://www.alfredjaeger.de)

### USA

Jaeger Spindles North America, Corp

Phone +1(770) 674-4480

E-Mail: [contact@jaegerspindles.com](mailto:contact@jaegerspindles.com)

Web: [www.jaegerspindles.com](http://www.jaegerspindles.com)

# APPLICATIONS



## GRINDING TECHNOLOGY

The diverse areas of application of grinding technology also demand a high degree of flexibility from the spindle system. Jäger high-frequency spindles can be used versatily and are accurate and safe in any area:

- ✓ Grinding in wet or dry environments
- ✓ Ideal for interior and exterior grinding
- ✓ Short spindle length with bearing designed accordingly
- ✓ Highest bearing and shaft stiffness

## COMPACT DESIGN WITH THE HIGHEST SHAFT STIFFNESS

Certain applications, e.g. the interior grinding of shafts, require extremely compact designs and high speeds. Here, the highest possible bearing stiffness must of course be ensured.

## TOUCH RECOGNITION

Touch recognition has the advantage that the contact between the dressing tool and the grinding wheel is detected. This makes more effective and flawless grinding possible.

## ALIGNED DRESSING PROCESS

In CNC dressing with rotating tools, the dressing process can be aligned specifically for the respective grinding task. The additional rotation movement results in a "soft" dressing of the grinding wheel compared to stationary dressers and therefore to a longer life. CNC dressing of grinding wheels with a rotating dressing tool makes it possible to influence the grinding process quickly and flexibly.

*As well as our specially designed solutions for mounted grinding points and wheels, we also offer special customised solutions.*



## ROBOT APPLICATIONS

Processing material using a robot poses the highest demands on the spindle system used. Absolute precision is the focus. Jäger high-frequency spindles are the right choice as far as weight, interfering contours and bearing rigidity are concerned:

- ✓ Low weight due to own motor development
- ✓ Large spectrum, from in-house WK taper change to HSK change system in different sizes

## MINIMUM INTERFERENCE CONTOUR

Particularly complex components are often processed by a robot. The robot's exceptional mobility makes its work very economically efficient. In order to achieve the precision required for the complicated contours, the highest demands are placed regarding efficiency, particularly in the automotive industry, in the same way as we place the highest demands regarding the efficiency of our spindles.

A special feature of our robot spindles is the tapering in the front area of the housing. The smaller diameter reduces the interfering contour to a minimum.

# APPLICATIONS

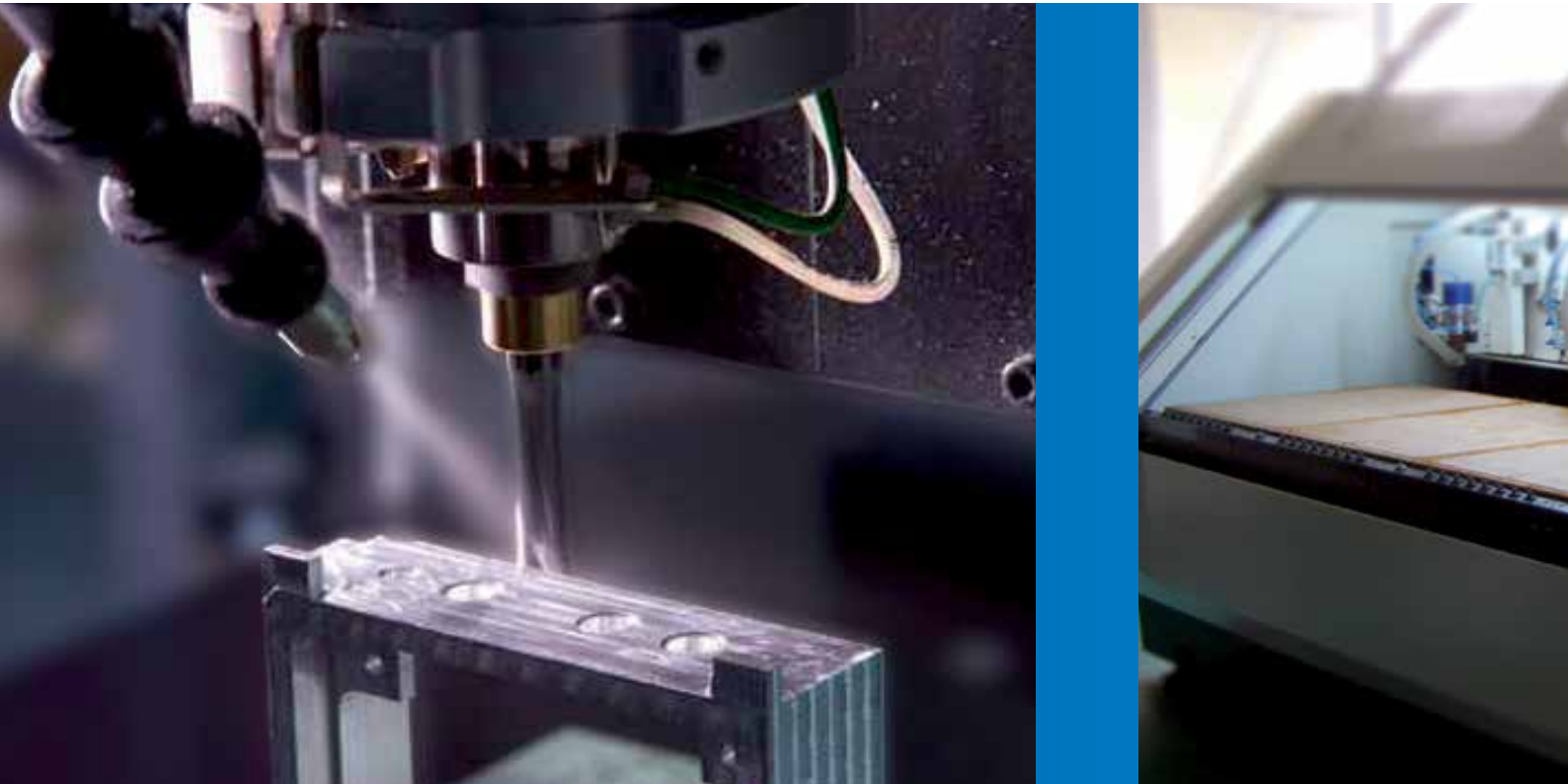

## TOOL AND MOULD CONSTRUCTION

Tool and mould construction has a special place in the manufacturing industry as almost every work piece is unique. The technical requirements for production are often complex and require the spindle used to be highly flexible and reliable.

The high-performance Jäger high-frequency spindles provide an ideal solution to the typical requirements of tool and mould construction.

Convincing advantages:

- ✓ Speeds of up to 100,000 rpm
- ✓ High speeds even with small tool diameters
- ✓ Spindles almost permanently operated at the maximum speed
- ✓ High machining forces
- ✓ 5-axle machining
- ✓ Spindles with a continuous power of 0.18 – 27 kW





## CONDUCTOR BOARDS

The manufacturing of conductor boards is a very complex sequence of production steps which must be coordinated exactly with each other. One of the most sensitive steps is depanelisation, i.e. the separation of the conductor boards processed in a compound structure. On the one hand, separation must be stress-free and on the other hand, it must be cleverly linked with the directly connected steps "testing" and "sorting".

## MINIMUM MECHANICAL LOAD

Many conductor board purchasers, such as device manufacturers or suppliers of the telecommunication and automotive industry stipulate that a stress-free separation procedure must be used. When separation is carried out by punching or shearing, this often results in considerable vibrations, which can lead to faults in the conductor boards and no longer complies with modern quality standards.

Separating using Jäger high-frequency spindles to mill and saw minimises the mechanical load significantly and therefore leads to a significant reduction in the fault rate.

Jäger spindles are also equipped with specially developed spindle-sealing air and rotation air ducts to clean the shaft and collet as well as with resistant centrifugal disks. This increases service lives enormously.



# APPLICATIONS



## DENTAL TECHNOLOGY

Modern milling units in dental technology have to show what fully automated production can achieve in the smallest spaces. Up to 7 traversing axles are available for treatment tasks.

### UNIQUE PRECISION AND SPEED

With speeds of up to 100,000 rpm (up to 60,000 rpm for steel ball bearings), the Jäger dental spindle series achieves unbeatable precision and speed, both for dry and wet grinding. This incredible speed saves not only time but also precious material when machining. This means economic efficiency with the highest precision. The milling machines can produce both individual caps and complex bridge frameworks at a favourable price.

### MODERN PROCEDURES IN DENTAL TECHNOLOGY

The highly developed CAD software analyses scan data and determines the optimum preparation limit as well as other parameters. For the best possible accuracy, users can use the software to carry out a precision adjustment on the virtual model. This innovative system can efficiently simulate manual craftsmanship and is therefore a guarantee for the best possible fit of the dental prosthesis.

*As well as our specially designed solutions for mounted grinding points and wheels, we also offer special customised solutions.*



## YOUR PARTNER FOR QUALITY AND INNOVATION

Every company needs expert partners in order to work successfully. This is why synergies are created, benefiting all those involved in the end. Alfred Jäger GmbH is your partner for high-quality and innovative spindle systems and for excellent service.

### QUALITY IS A PROCESS AND NOT A STATE

In a world that is constantly progressing, staying still means going backwards. This particularly applies to the quality of products and services. We will never stop! By means of regular quality circles, we constantly put our products, our service and, of course, ourselves to the test. We want to continually improve every day. Not only our location in Germany, but also our partners around the world are certified by the Jäger quality and service system.

### ALWAYS AT THE CUTTING EDGE

Thanks to these quality circles and our development department, you are guaranteed to acquire a product that is state of the art. On top of that, you even get an update during repairs, as even more developed parts are always installed, thereby modernising your system. It goes without saying that this update is part of the service.



## YOUR PARTNER FOR EXCELLENT SERVICE

Our high quality standards of course do not only apply to our products, but also to our service. This is where the strength of a good partnership proves itself.

### SHORT REPAIR TIMES

Since we develop and produce everything from one source, our highly qualified employees and our extensive parts warehouse are also available for service. It goes without saying that this leads to unbeatably short repair times.

### THERE'S A FASTER OPTION

Use our express service. Here we check whether it is possible to run your spindle through the service stations at top speed.

### WHEN WILL THE SPINDLE BE READY?

Simply use our online service. Log into our repairs system at [www.alfredjaeger.de](http://www.alfredjaeger.de). There you can find out the processing status and the expected duration of the repair.

### TELEPHONE CONSULTATION

Do you have any questions about our spindle systems or about peripheral equipment? Just give us a call: +49 6002 91 23 - 93

Our employees are available for you from 7 am, from Monday to Friday.

# ON-SITE CONSULTATION



## ON-SITE CONSULTATION

We are happy to come to you or to meet at your customer's location as you desire, and will bring one of our engineers if required.

### OUR "START SERVICE"

If you are using a Jäger spindle system for the first time or you want to replace an existing Jäger system, we will carry out the necessary installation work together with you on your machine.

### OUR "TEST SERVICE"

You can, of course, also use our spindles on other peripheral equipment. But will the machining result still live up to your expectations? There is a way to find out: test your frequency converter with us in-house on one of the biggest spindle power test benches in the world.

### SAFETY FIRST

To ensure that your production chain flows problem-free, we recommend our maintenance service. We carry out all the required maintenance and cleaning work on your spindles and periphery equipment at regular intervals.

# ACCESSORIES

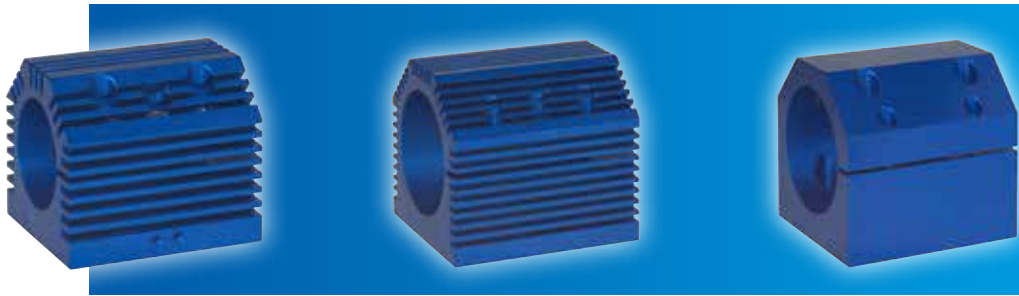

## SPINDLE HOLDER / SPINDLE FLANGE

Spindle holders or customised spindle flanges for the fixing of the Z-spindle series.

Regular quality circles are used to put our products and services to the test time and time again and to improve them continuously. This not only takes place here in Germany; our other

partners around the world also maintain service stations to an extent, and these are certified by the Jäger quality and service system.



## TOOL CHANGE STATIONS

Pick-up stations for various types





### COOLING UNITS

Cooling units for liquid-cooled high-frequency spindles. Also available as a 19-inch insert, housing version or as a system cabinet (cooling unit and converter)

- ✓ from 600 to 2500 W
- ✓ up to an ambient temperature of 42°C



### FREQUENCY CONVERTERS

Frequency converters to operate high-frequency spindles. Available as a table-top unit, switch cabinet version, 19-inch insert, in the housing or as a system cabinet (coolant unit and frequency converter).

- ✓ 0.08 kW – 67 kW output

Tool mounts can be found in our separate catalogue.

# CONTACT PARTNERS

## WE ARE AVAILABLE:

**Mon-Thurs** 7 am - 4 pm  
**Fri** 7 am - 1 pm

## SALES: NEW GOODS

**Phone** +49 (0)6002 91 23 91  
**Fax** +49 (0)6002 91 23 46  
**E-mail** sales@alfredjaeger.de

## SERVICE, REPAIRS, DOCUMENTATION, REPLACEMENT PARTS

**Phone** +49 (0)6002 91 23 93  
**Fax** +49 (0)6002 91 23 45  
**E-mail** service@alfredjaeger.de



## ALFRED JÄGER GMBH

Siemensstraße 8  
61239 Ober-Mörlen  
Hesse, Germany

**Phone** +49 6002 9123-0  
**Fax** +49 6002 9123-40

**E-mail** info@alfredjaeger.de  
**Internet** www.alfredjaeger.de



DIN EN ISO 14001:2004  
BS OHSAS 18001:2007  
Certificate: 0710008Jäg00