

ANGLE HEADS

Tooling technology

Metal machining

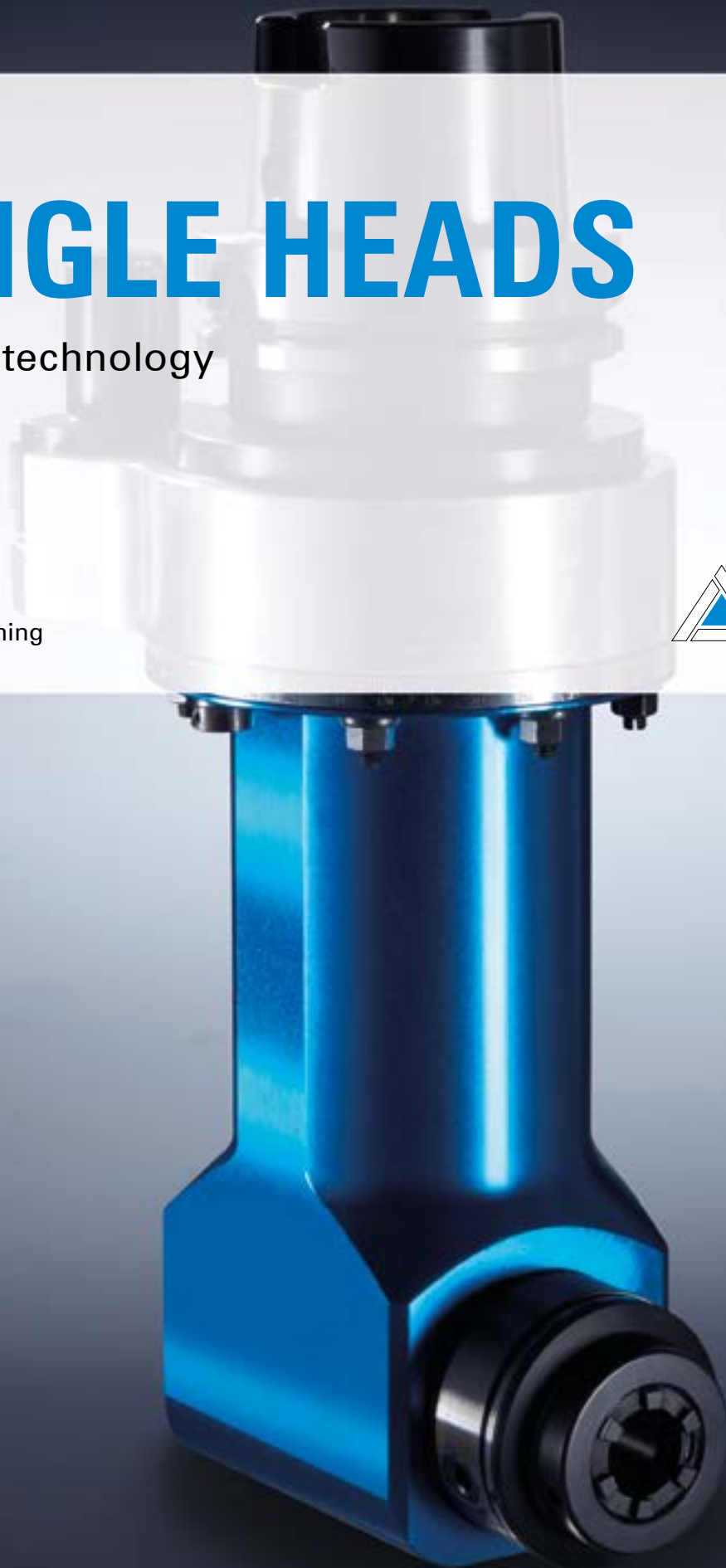



AT BENZ GMBH WERKZEUGSYSTEME, OUR MAXIM “INNOVATION, PRECISION, PASSION“ IS FAR MORE THAN JUST A MARKETING FORMULA. RATHER, IT DESCRIBES THE CORE GOALS OF OUR BUSINESS WHILE ALSO OUTLINING THE REASONS WHY WE HAVE BEEN ABLE TO COMPETE IN THE MARKET SUCCESSFULLY WITH TOOL SYSTEMS FOR WOODWORKING, METAL MACHINING AND COMPOSITE MATERIAL PROCESSING FOR MORE THAN 30 YEARS.

INNOVATIONS ARE IMPORTANT TO US. BUT WE ALSO RECOGNIZE THAT THEY CAN BE SUCCESSFUL ONLY IF THEY PRECISELY MEET THE NEEDS OF OUR CUSTOMERS. THIS IS WHY WE HAVE MAINTAINED A STRICT FOCUS ON OUR CUSTOMERS FOR MANY YEARS. WE ENSURE THAT OUR DEVELOPMENTS AND INNOVATIONS SIMPLIFY YOUR PRODUCTION PROCESSES AND LOWER YOUR MANUFACTURING COSTS AND ULTIMATELY IMPROVE YOUR COMPETITIVENESS AS A RESULT.



BENZ GMBH

WERKZEUGSYSTEME

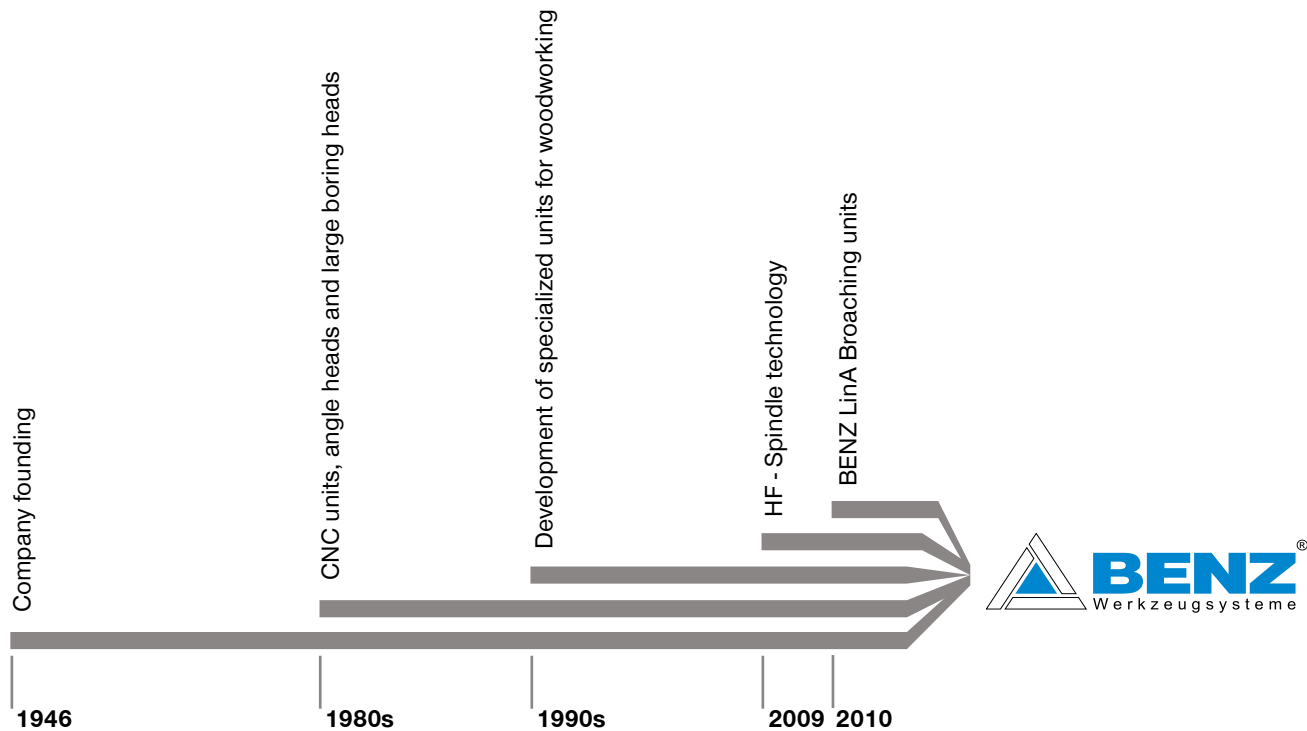

BENZ PRECISION PRODUCTS PROVIDE REFINED SOLUTIONS, INNOVATIVE TECHNOLOGY AND THE HIGHEST LEVEL OF QUALITY. WHAT IS THE SECRET TO THIS SUCCESS? OUR EMPLOYEES AND THEIR INVALUABLE EXPERTISE MAKE THE DIFFERENCE.

Innovation. With an eye on what is currently within the bounds of feasibility, we strive to always make use of innovative technologies. And we keep in close contact with our customers to ensure we already know today what our customers will need tomorrow. Technical progress is ingrained into our very identity, which means you can always find smart, detailed solutions in our product range.

Precision. We ensure our products have the highest level of precision and reliability. This is vital in our industry. Our customers also rely on absolute precision during production—and need to be able to put all their trust in us. But production is not the only area where we strive for precision. We also seek minimal tolerances and maximum accuracy in other areas as well—from development to sales to delivery.

Passion. BENZ precision products are composed of a vast array of different individual parts. They are the result of great care that starts in the design phase and even includes the selection of raw materials. Primarily, however, they are the expression of our employee's experience and passion to do good work. We are tool specialists through and through and we are willing to move mountains to reach the perfect solution and to ensure the satisfaction of our customers.

PRODUCT GROUPS

TOOLING AND MACHINE TOOLING TECHNOLOGY

TOOLING TECHNOLOGY



LIVE TOOLS/ TOOL HOLDERS

- + Radial heads 90°
- + Radial heads ≠ 90°
- + Axial heads
- + Swivel heads
- + Multi-spindle heads
- + Broaching units
- + Rotating tool holders
- + Static tool holders

Components. Our comprehensive tool concepts for turning centers and milling centers are ideal for nearly every application. Providing a technological advantage is our goal.

Specific to the customer. Our modular approach enables customized configurations.

Systems. We develop special customer-specific tools for OEM and end customers on request.

EXCHANGEABLE UNITS

- + Angle heads 90°
- + Angle heads ≠ 90°
- + Swivel heads
- + Multi-spindle heads
- + Broaching units
- + High-speed spindles

Knowledge and experience. Our knowledge of the metalworking industry and decades of development partnership make us ideal for new tasks anywhere in the world.

Components. We deliver a vast array of standard components from stock and develop innovative, customized systems for OEM and end customers.

Variety. Whether in machining centers in the automotive, aerospace or wind energy industries, units from Benz can be used anywhere. Numerous customers choose us as their systems and innovation partner.

EXCHANGEABLE UNITS

- + Angle heads 90°
- + Swivel heads
- + Multi-spindle heads
- + Multi-axis heads
- + Sanding units
- + Floating head units

For any application. Cost-effectively process and machine wood, composites and aluminium: We provide series production angle heads for drilling, milling, sawing and grinding in addition to other units for special applications.

From basic to high-end. Benz units are available in a variety of performance classes, making them ideal for everything from light machining to high-performance continuous operation.

Systems. We have the solution for your special applications: Customized Benz units for machining centers. Put us to the test!

METAL

WOOD/COMPOSITE MATERIALS

MACHINE TOOLING TECHNOLOGY

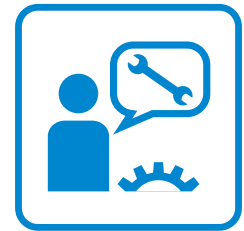

MULTI-SPINDLE HEADS AND LARGE DRILL HEADS

- + Large angle heads
- + Large drill heads
- + XXL multi-spindle heads

Development partner. We accompany you from brainstorming to inspection of the final machine, always to your expectations. Our assortment ranges from compact heads to XXL units.

Systems. Benz stands for high-end solutions in the fields of machine tooling technology, specialty solutions, custom assemblies and mechanical modules. We manufacture and configure multi-spindle and large-angle heads as well as large drill heads.

Components. Attachment units complete our range.

SYSTEM TECHNOLOGY

- + Multiple-spindle drill heads
- + Motor spindles
- + Motors
- + 5-axis technology
- + C-axes
- + Swivel axes
- + Rotary distributors
- + Z-axes

Components. Our range includes standard products in an assortment of shapes and sizes.

The perfect addition. Our system additions provide you with even more efficiency. Perfect your existing solutions with Benz products!

Systems. We develop the technology of tomorrow. Your individual requirements for the efficiency of your machine tools and the suitability of the tools in use provide our benchmark for new, innovative solutions.

SERVICE

- + Repair service
- + ExpressService
- + Customized crash package
- + Preventive maintenance
- + Spare part management
- + Global service
- + Service hotline

Do not lose a second. Speed is the order of the day when unexpected breakdowns occur. Our service center ensures immediate assistance around the world. We ensure your machine has as little downtime as possible.

Service quality. We guarantee top service quality reflecting our expertise as a manufacturer.

Foresight. We go one step further: Preventive maintenance, customized crash packages and our spare part management service ensure you have the best setup to face any emergency. We look to the future to keep you at your peak.

TOOLING TECHNOLOGY

METAL MACHINING

EXCHANGEABLE UNITS

ANGLE HEADS IN OVERVIEW



SYSTEM DESIGN

1 Page 8



DESIGN OVERVIEW

2 Page 19



CUSTOMISED SPECIAL SOLUTIONS

3 Page 74



i.com

EQUIPMENT VERSIONS

4 Page 78



SERVICE

5 Page 84



ORDER INFORMATION

Page 86

1

2

3

4

5

ANGLE HEADS

SYSTEM DESIGN

1

System design / Angle heads

► ECONOMICAL COMPLETE MACHINING FOR ALL SECTORS

Angle heads suitable for your individual application

Do you have an application for which an angle head is worth considering for machining a workpiece? Then you are right to come to BENZ GmbH Werkzeugsysteme. Why?

As a partner working with CNC machining, we have many years of experience in the manufacture of CNC machining units for machining centres. We know what we are talking about. And we implement what we say. This is reflected in the angle heads that feature high performance, machining precision and quality.

Our objective is to optimize your production sequence. BENZ angle heads assist you in the economic complete machining of your workpieces by minimising the number of tool clampings and machining time and therefore reducing your production costs.

We develop a suitable solution in close cooperation with you as the customer. Together with an extensive standard program, we also offer you individual special solutions. We maintain close contact with machinery manufacturers and therefore have the necessary know-how to develop the exceptional. Challenge us!

BENZ solutions for all sectors



► ADDED VALUE FOR YOUR MACHINE

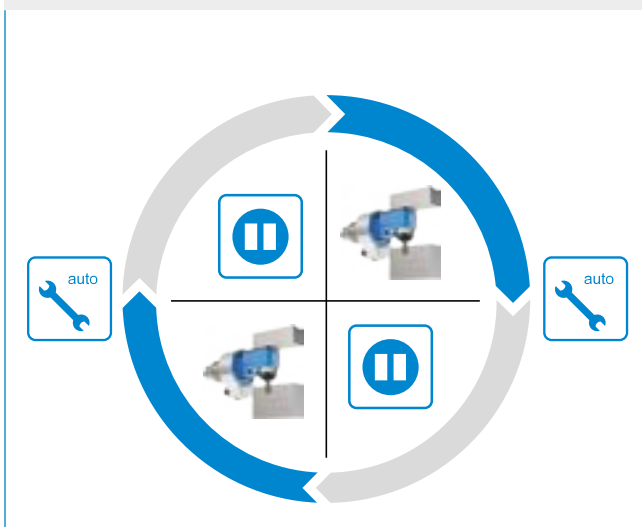

► Angle head additional module

Angle heads are additional modules that extend the functionality of your tool machine. They are typically used cyclically in the machining process. As a rule unit is at rest after a machining step while the unit is changed and further processing is performed with another tool.

▶ ADVANTAGES OF ANGLE HEADS

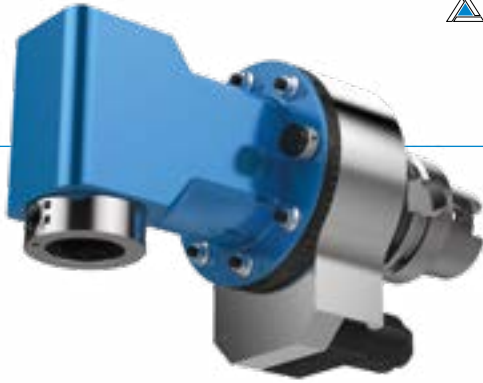

▶ **Reduction of machining time / production costs**

BENZ angle heads enable the complete machining of complex workpieces on a machine. Repeated tool clamping is dispensed with. This reduces the machining time and therefore the costs and increases accuracy.

▶ **Efficiency increase / Internal machining**

Even locations on workpieces that are difficult to access or were previously inaccessible can be machined with angle heads.

▶ **Simplification of the machining procedure**

Elaborate and complicated machining procedures can be simplified considerably by using BENZ angle heads.

▶ **Usable in all common machine concepts**

BENZ angle heads are designed for use in all common machining centres with automatic or manual tool change.

▶ **Optimally designed for the machining task**

BENZ angle heads are perfectly matched by our specialists to your individual requirements. We have a suitable solution for every challenge!

▶ **High torque transmission / fewer wear parts**

The transmission of high torques and fewer wear parts are realised by using angular gears made up of a crown wheel and spur wheel.

▶ **Compact, modular design**

BENZ angle heads have an extremely compact design and consist of components including the output spindle (tool holding/clamping system), angle head, torque support and drive cone. Together we prepare the angle head suitable for your work task.

ANGLE HEADS

SYSTEM DESIGN

► SYSTEM DESIGN - GENERAL



① Drive cone / Machine interface

- For holding the angle head in the machine
- All common drive cones available: see p. 11

② Locking disc

- Ensures the exact angle setting of the drive cone for the torque support in combination with the locking sleeve and locking pin

③ Lock

- The lock of the drive cone - together with the locking disc - prevents the drive turning when it is not changed. This enables precise depositing in the tool change magazine. When change the angle head in the machine, the lock is activated by the stop block and the drive is released

④ Torque support

- Secures the angle head against turning during machining by fixing it to the machine spindle
- As a rule it is adapted to the relevant machine type: see p. 11
- Alternative: Standard torque support from BENZ

⑤ Scale ring (360°)

- For manual, stepless turning of the angle head at a desired working angle
- Fixing using clamping screws

⑥ Housing / Angle head body

- Different types and sizes of design available for delivery according to application: see P. 15ff.

⑦ Output spindle (tool holding / clamping system)

- For holding the tool
- All common clamping systems can be realised: see p. 11

Optional: Equipment versions

COOLANT SUPPLY

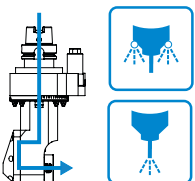

Page 78

ADDITIONAL SUPPORT



Page 79

STOP BLOCK



Page 80

BENZ I.COM



Page 82

► MODULAR DESIGN

REQUIREMENTS

CHANGE THE ANGLE HEAD



MACHINING CASE



MACHINE TYPE



OUTPUT SPINDLE
(TOOL HOLDING / CLAMPING SYSTEM)



ANGLE HEAD COMPONENTS

OUTPUT SPINDLE / CLAMPING SYSTEM

all common output spindles can be realised



DESIGN / SIZE

the design and size are matched with the respective machining case

Design - from page 19



Sizes



TORQUE SUPPORT

primarily a machine-related design

alternative: BENZ standard torque support

DRIVE CONE

all common drive cones can be realised



i Individual customer requirements, e.g. drive cones, output spindles, etc. not listed here, can be realised on request. Please contact us!

MULTI-SPINDLE HEADS

TOOL INTERFACES

1

Advantages / Multi-spindle heads

▶ BENZ MODULAR QUICK CHANGE SYSTEMS



BENZ Solidfix®
Output spindle



BENZ CAPTO™
Output spindle



BENZ Nanofix®
Output spindle

- ▶ **Modular design**
via basic tool and exchange unit with various tool holders
- ▶ **Minimize setup- and nonproductive time**
via change of the pre-set tool within seconds
- ▶ **Much lower investment**
as the basic tool stays on the machine and only the adapters are changed in total fewer basic tools are needed
- ▶ **Simple handling**
by one-hand operation, without special tools
- ▶ **Operator safety**
tool cannot fall out

▶ REDUCE SETUP TIME = SAVE COSTS

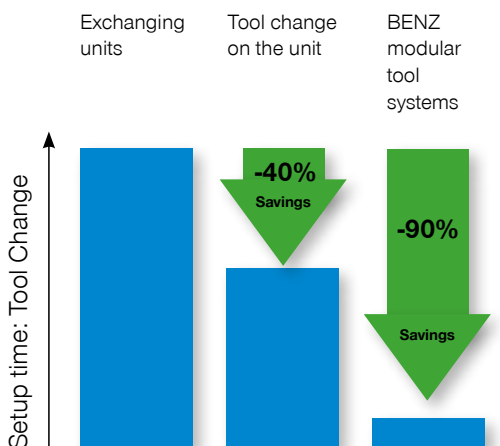





Long machine standstill times arise for a tool change where the complete unit is taken out of the machine. By changing the cutting tool directly on the unit, setup times can already be reduced by 40%. The optimum can be achieved with modular quick-change systems. Here the cutting tool is measured outside of the machine in the presetting device. Replacing the adapter therefore only requires a few seconds. You save 90% of your original setup costs! You also reduce your reject rate as the first part is already a good part.

▶ SHORT DESCRIPTION

▶ BENZ SOLIDFIX®

User-friendly, stable and extremely precise

Due to the combination of a zero-play cone-centering unit with an extremely large and flat contact surface in conjunction with high clamping forces, BENZ Solidfix® provides a maximum of tilt resistance and stability, which also meets the requirements for milling. The high torque transfer and the high potential speeds also characterize the performance capability. This is supported by a special clamping mechanism, which operates centrally, without lateral forces, and works together with the high-precision and compact components to achieve top values for concentricity, bending stiffness and repeatability. The structural design makes the system optimally suited for IC tools.





			
+++	++	+++	+++



▶ BENZ CAPTO™

Increase efficiency and processing quality

The BENZ CAPTO™ modular quick-change system guarantees an extremely compact design through the well-conceived integration of the clamping set into the spindle. Special clamping kinematics provide for clamping forces that are significantly above the specifications in ISO/DIS 26623-2. BENZ CAPTO™ can be used for turning on a lathe, milling and drilling with a coolant pressure of up to 100 bar. The system is particularly suited also for heavy-duty cutting.





			
+++	+	+++	+++



▶ BENZ NANOFIX®

Quick change in confined spaces

BENZ Nanofix® is a new quick-change interface that is convincing thanks to its extremely compact design. The outer diameter of 22 mm is designed for minimal spindle distances and is therefore particularly suitable for use in confined spaces.

			
+++	+	+++	+++



OUTPUT SPINDLES ACCESSORIES

Please see our catalog for detailed information on our modular quick change system as well as all accessories:

TOOLING TECHNOLOGY / MACHINE TOOLING TECHNOLOGY BENZ MODULAR QUICK CHANGE SYSTEMS

- ▶ Adapters BENZ Solidfix®
- ▶ Adapters BENZ CAPTO™
- ▶ Accessories for collet chucks
- ▶ Wrenches
- ▶ Miscellaneous



ALSO AVAILABLE ONLINE
IN THE DOWNLOAD AREA

Scan the QR code or visit our website:

- ▶ <http://www.benz-tools.de/en/services/downloads>





ANGLE HEADS



















SYSTEM DESIGN















1

System design / Angle heads

▶ PICTOGRAM AND ABBREVIATION OVERVIEW

▶ Angle head specifications

Pictogram						
Change the unit	 Automatic BENZ standard angle heads can generally be automatically changed	 Manual The angle heads can also be manually changed as an option				
Machining	 Drilling The angle head is suitable for drilling operations	 Milling The angle head is suitable for milling operations	 Threading The angle head is suitable for threading operations			
Number of output spindles	 1 The angle head has an output spindle	 2 The angle head has two output spindles	 X The angle head has X output spindles (multi-spindle head)			
Axis angle	 90° Angle head for machining tasks at 90° angle	 0°-120° Angle head for machining tasks in fixed angular position	 0°-100° Angle head for machining tasks at flexible angle. Any angle can be set.			
Coolant supply for cutting edge	 External (EC) The tool is cooled via an external line (spray nozzle)	 Internal (IC) The tool is cooled using an internal line directly through the spindle	 Combination The cooling of the tool is combined - internally and externally	 No coolant supply The angle head does not have a coolant supply as standard		
Types of cooling (coolants)	 Water cooling The tool cutting edge is cooled with water	 Oil cooling The tool cutting edge is cooled with oil	 MQL The tool cutting edge is cooled with minimal quantity lubrication (oil/air)	 Air cooling The tool cutting edge is cooled with air		

Pictogram	▶ General specifications		
Information	 Important information Caution! Important Note. Please read this carefully.	 Video	
Pause	 Pause The angle head is not used for machining.		
Advantages	 Time savings	 Kost savings	 Easy handling
	 Safe handling		
Sectors	 Automotive	 Machine construction	 Aerospace
	 Medical	 Plastics technology	 Wind power
Services	 Service Services, e.g. repair, preventative maintenance, etc.		

▶ **Abbreviations**

M_{max} Maximum torque (input and output)

M_{2max} Maximum torque (output)

i Transmission ratio

n_{max} Maximum speed (input and output)

n_{2max} Maximum speed (output)

p_{max} Maximum pressure (bar)

EC External cooling

IC Internal cooling

p. Page

✓ possible

- not possible

- / ✓ for EC: without cooling as standard, with external cooling as an option

pc. Piece

AF Wrench size

kg Kilogram

ANGLE HEADS

ORDER INFORMATION

Selection of angle heads

- ▶ According to design, size, drive cone, output spindle
- ▶ Please inform us of this information in your request

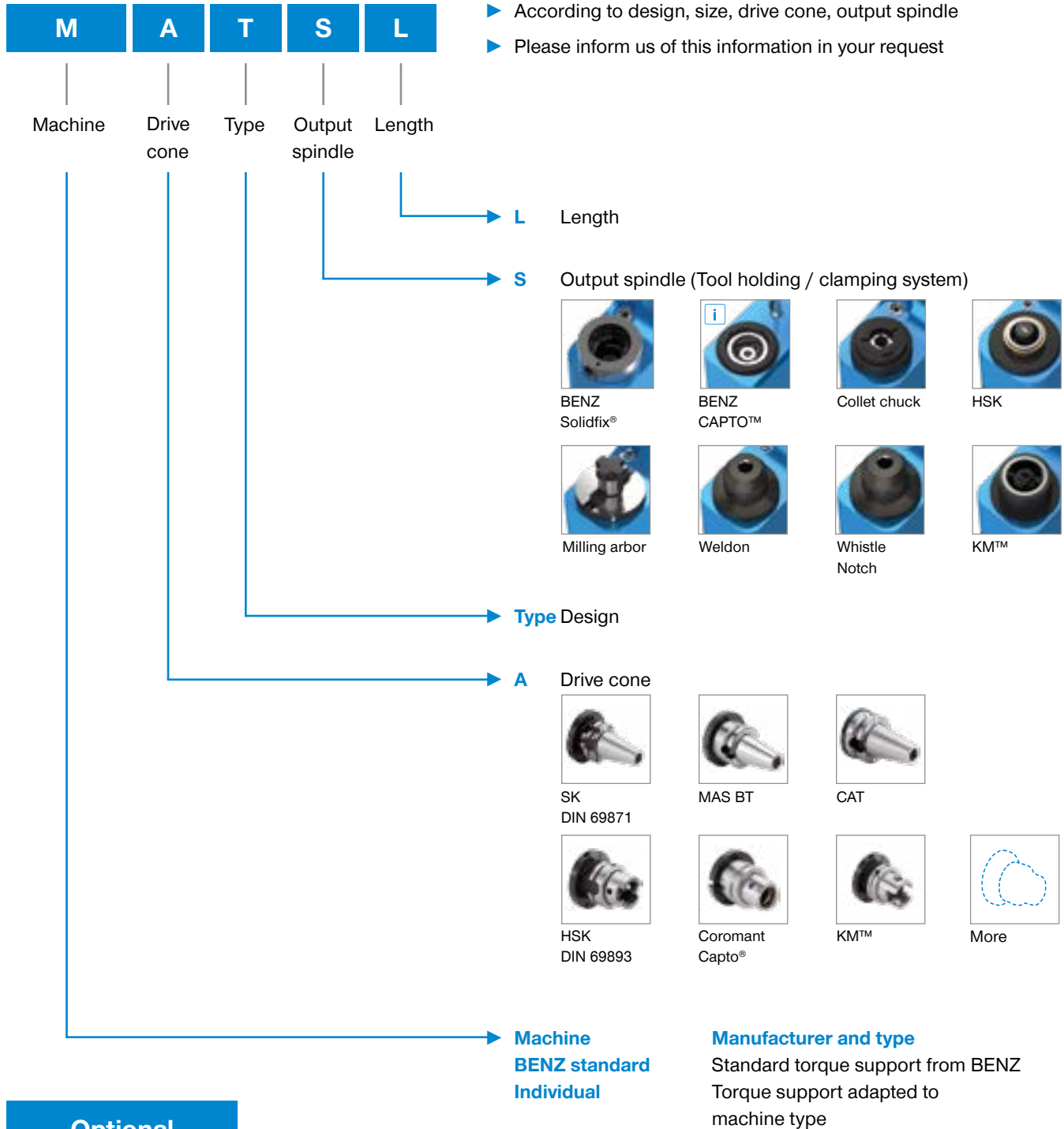

Note:

- ▶ The products represented in this catalogue use standard components. We will gladly develop suitable solutions for your individual requirements together with you.

ANGLE HEADS IN OVERVIEW

DESIGN



MONO WSX

Angle head 90°
Machining: without spatial constraint
Optional: with EC

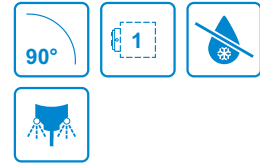

20



DUO WZX

Angle head 90° - output spindle on both sides
Machining: in opposite direction / with different tools
Optional: with EC

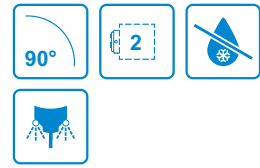

28



FORTE WWX

Angle head 90° - reset output spindle / tool holding fixture
Machining: for spatial constraint / maximum useable tool length
Optional: with EC, IC or EC/IC combination

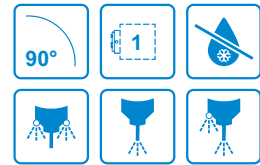

36



SLIM WGX / SLIM WGX-S

Angle head 90° - narrow or extremely narrow design
Machining: for extreme spatial constraint / maximum useable tool length
Optional: with EC

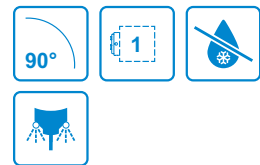

44



FIX WFX

Angle head 0°-120° - with fixed angle
Machining: special machining at fixed angle
Optional: with EC, IC or EC/IC combination

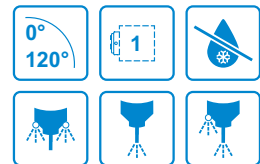

56



FLEX WDX

Angle head 0°-100° - with flexible angle / stepless adjustment
Machining: in any variable position
Optional: with EC, IC or EC/IC combination

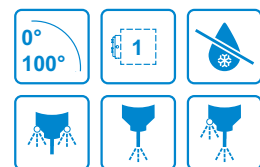

64

ANGLE HEAD MONO WSX

► MODULAR DESIGN



► ANGLE HEAD BODY (SIZE)

04

05

07

15

20

► OUTPUT SPINDLE / CLAMPING SYSTEM



BENZ
Solidfix®



BENZ
CAPTO™



Collet chuck



HSK



Milling arbor



Weldon



Whistle
Notch



KM™

► DRIVE CONE



SK



MAS BT



CAT



HSK
DIN 69893



Coromant
Capto®



KM™

► Specifications

Change the
angle head



Machining



Number of
output spindles



Axis angle



Coolant supply



Option

MONO WSX

► Angle head without IC

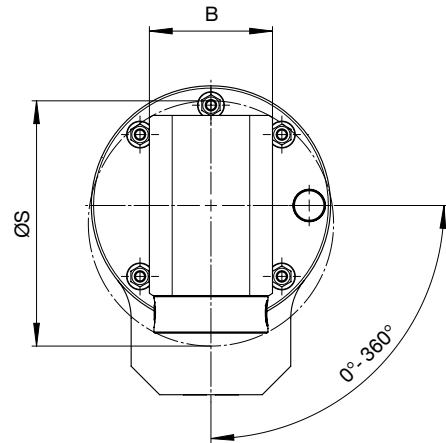
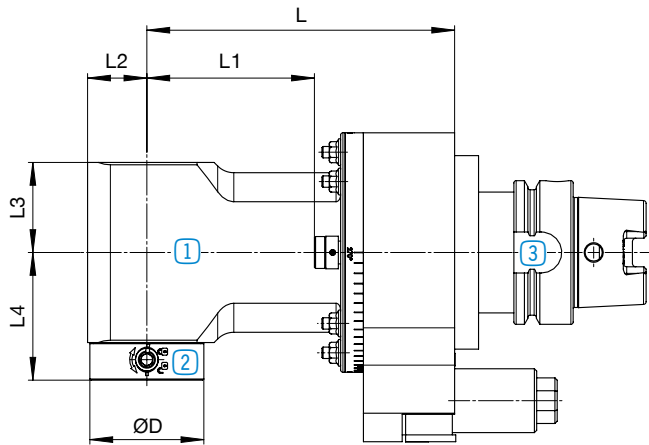

1 Angle head body
Page 22



2 Output spindle /
Clamping system
Page 24



3 Drive cone
Page 26



Other dimensions for angle heads with BENZ CAPTO™ output spindle. Dimensions available on request.

ANGLE HEAD MONO WSX

▶ ANGLE HEAD BODY (SIZE)



i More sizes on request.
Higher speeds are possible as an option.

▶ Angle head without IC

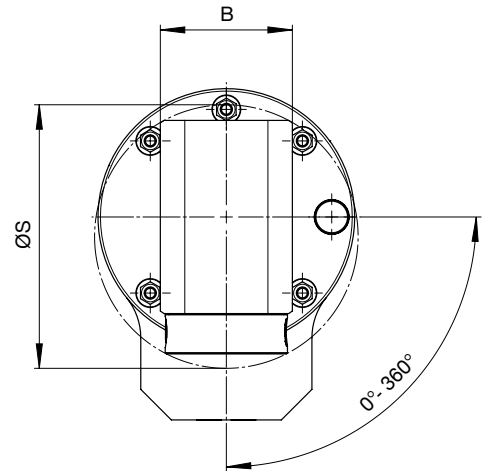
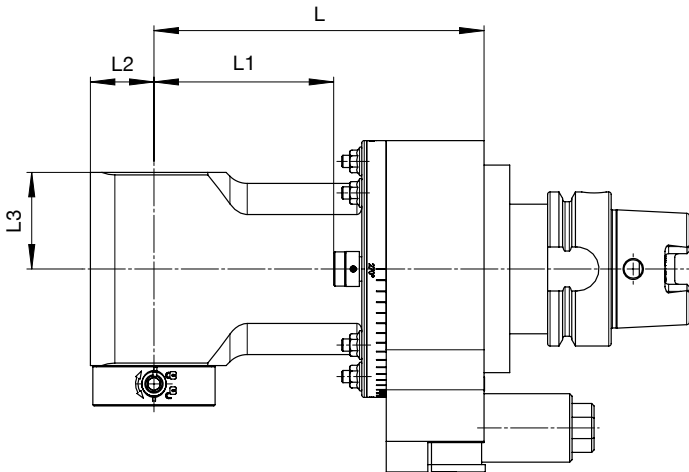

Size 04		▶ Technical data								
		L1 [mm]	L2 [mm]	L3 [mm]	B [mm]	ØS [mm]	L [mm]	EC*	IC	Weight [kg]
M _{max}	= 15 Nm	43.5					95			4
i	= 1:1	93.5	24	35.5	46	95	145	-	-	4.3
n _{max}	= 10,000 rpm	123.5					175			4.5

Size 05		▶ Technical data								
		L1 [mm]	L2 [mm]	L3 [mm]	B [mm]	ØS [mm]	L [mm]	EC*	IC	Weight [kg]
M _{max}	= 30 Nm	26.5					88	-		5
i	= 1:1	73.5	26	39.5	54	108	135	- / ✓	-	5.5
n _{max}	= 8,000 rpm	133.5					195	- / ✓		6.5
p _{max}	= 70 bar*									

Size 07		▶ Technical data								
		L1 [mm]	L2 [mm]	L3 [mm]	B [mm]	ØS [mm]	L [mm]	EC*	IC	Weight [kg]
M _{max}	= 70 Nm	43.5					105	-		8.5
i	= 1:1	88.5	35	51	80	141	150	- / ✓	-	9.5
n _{max}	= 6,000 rpm	153.5					215	- / ✓		11
p _{max}	= 70 bar*									

Size 15		▶ Technical data								
		L1 [mm]	L2 [mm]	L3 [mm]	B [mm]	ØS [mm]	L [mm]	EC*	IC	Weight [kg]
M _{max}	= 150 Nm	85.5					155	-		14.5
i	= 1:1	155.5	40	63	92	169	225	- / ✓	-	17
n _{max}	= 4,000 rpm	228.5					298	- / ✓		19.5
p _{max}	= 70 bar*									

Size 20		▶ Technical data								
		L1 [mm]	L2 [mm]	L3 [mm]	B [mm]	ØS [mm]	L [mm]	EC*	IC	Weight [kg]
M _{max}	= 230 Nm	101					171	-		16.5
i	= 1:1	171	45	63	100	182	241	- / ✓	-	19
n _{max}	= 3,000 rpm	241					311	- / ✓		21.5
p _{max}	= 70 bar*									



*Optional: EC via spray nozzle

ANGLE HEAD MONO WSX

▶ OUTPUT SPINDLE / CLAMPING SYSTEM



i Technical data for other output spindles / clamping systems on request:



Weldon



Whistle
Notch



KM™

i We show you **preferable sizes** in the following tables. Smaller output spindles are possible at any time as an option.

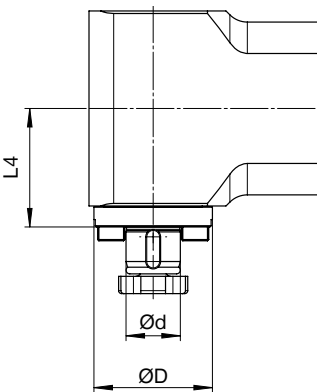
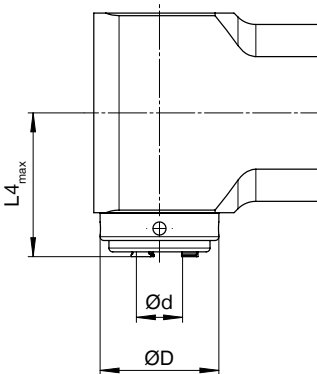

▶ Technical data

Collet chuck	Size	L4 _{max} [mm]	ØD [mm]	Ød _{max} [mm]
ER16A	04	46	44	10
ER20A	04	54	44	13
ER25A	05	57	47	16
ER32A	07	69	55	20
ER40A	15	82	70	30
ER40A	20	85	75	30



▶ Technical data

Milling arbor	Size	L4 [mm]	ØD [mm]	Ød [mm]
22	05	48	48	22
27	07	62.5	60	27
32	15	76	75	32
40	15	77.5	80	40
40	20	77,5	80	40

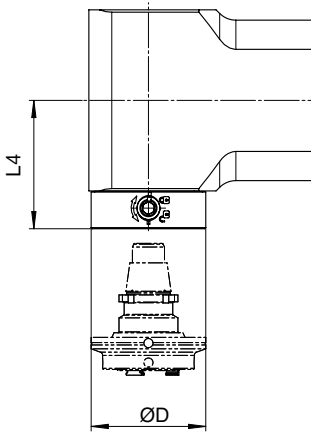

i For adapters and dimensions, see catalogue
BENZ Modular Quick Change Systems



BENZ Solidfix®

	Size	L4 [mm]	ØD [mm]
S2	04	49.5	40
S3	05	56	50
S4	07	72	63
S5	15	86	75
S5	20	90	75

► Technical data

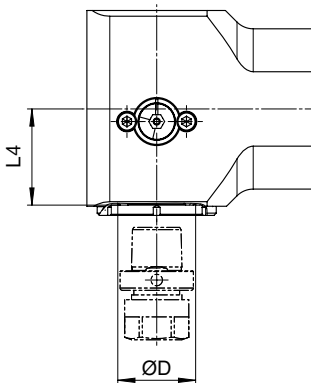

i For adapters and dimensions, see catalogue
BENZ Modular Quick Change Systems



BENZ CAPTO™

	Size	L4 [mm]	ØD [mm]
C3	05	42	32
C4	07	52	40
C5	15	60	50
C6	20	80	63

► Technical data

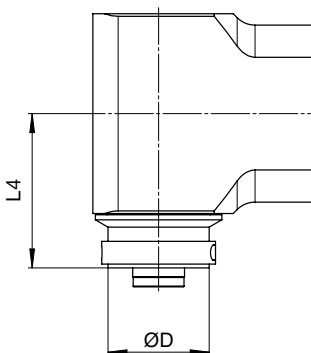

HSK

	Size	L4 [mm]	ØD [mm]
HSK 40	05	59	40
HSK 50	07	68	50
HSK 63	15	93	63
HSK 63	20	99	63

► Technical data

ANGLE HEAD MONO WSX

► DRIVE CONE



Technical data for other machine interfaces on request.

Type: Steep taper



	► Size				
SK DIN 69871	04	05	07	15	20
SK 40	✓	✓	✓	-	-
SK 50	✓	✓	✓	✓	✓



	► Size				
MAS BT	04	05	07	15	20
BT 40	✓	✓	✓	-	-
BT 50	✓	✓	✓	✓	✓



	► Size				
CAT	04	05	07	15	20
CAT 40	✓	✓	✓	-	-
CAT 50	✓	✓	✓	✓	✓

Type: Hollow shank taper



	▶ Size				
HSK DIN 69893	04	05	07	15	20
HSK 40	✓	-	-	-	-
HSK 50	✓	✓	-	-	-
HSK 63	✓	✓	✓	-	-
HSK 80	✓	✓	✓	✓	-
HSK 100	✓	✓	✓	✓	✓



	▶ Size				
Coromant Capto®	04	05	07	15	20
C3	✓	-	-	-	-
C4	✓	✓	-	-	-
C5	✓	✓	✓	✓	-
C6	✓	✓	✓	✓	✓
C8	✓	✓	✓	✓	✓



	▶ Size				
Kennametal™	04	05	07	15	20
KM 40	✓	-	-	-	-
KM 50	✓	✓	-	-	-
KM 63	✓	✓	✓	-	-
KM 80	✓	✓	✓	✓	-
KM 100	✓	✓	✓	✓	✓

ANGLE HEAD DUO WZX

► MODULAR DESIGN

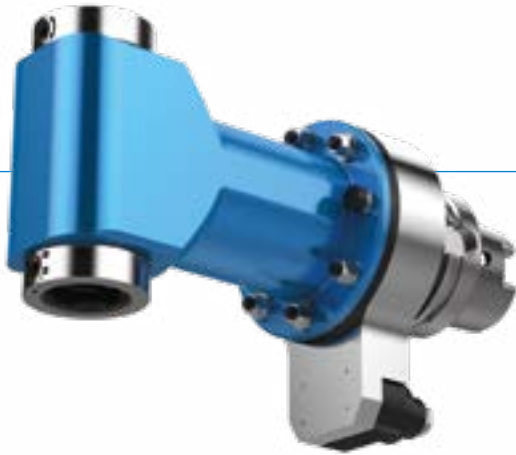

► ANGLE HEAD BODY (SIZE)

04

05

07

15

20

► OUTPUT SPINDLE / CLAMPING SYSTEM



BENZ
Solidfix®



Collet chuck



HSK



Milling arbor



Weldon



Whistle
Notch



KM™

► DRIVE CONE



SK
DIN 69871



MAS BT



CAT



HSK
DIN 69893



Coromant
Capto®



KM™

► Specifications

Change the
angle head



Machining



Number of
output spindles



Axis angle



Coolant supply



DUO WZX



Option

► Angle head without IC

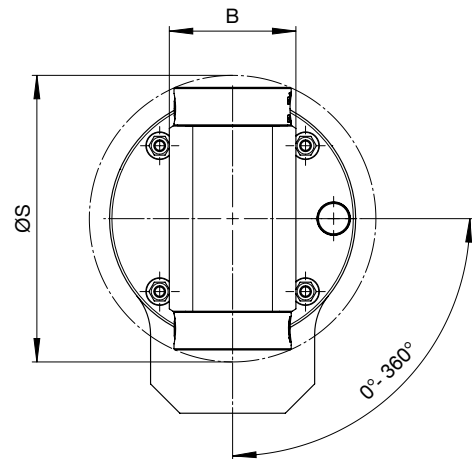
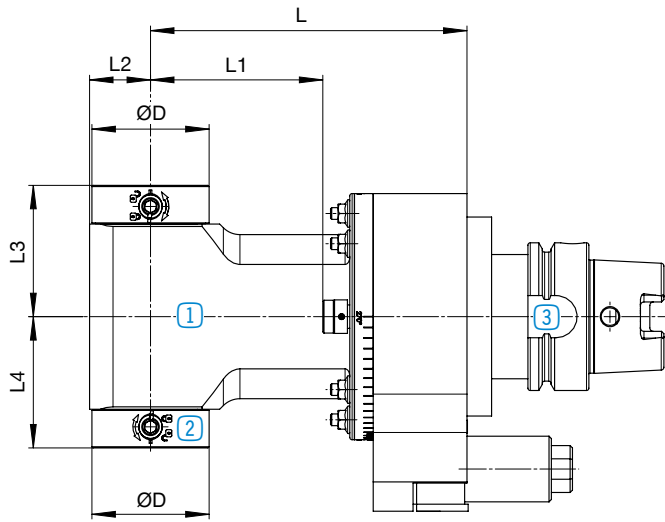

1 Angle head body
Page 30



2 Output spindle /
Clamping system
Page 32



3 Drive cone
Page 34

ANGLE HEAD DUO WZX

▶ ANGLE HEAD BODY (SIZE)

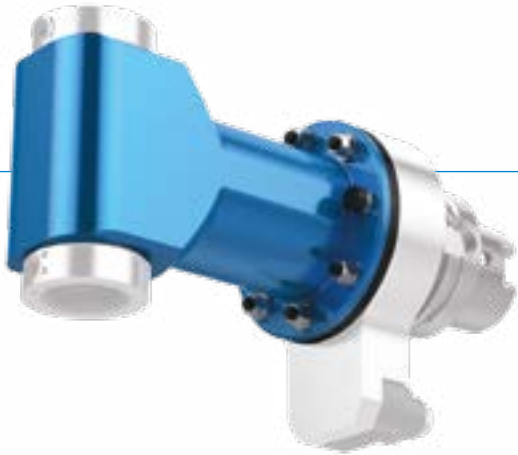

More sizes on request.
Higher speeds are possible as an option.

▶ Angle head without IC

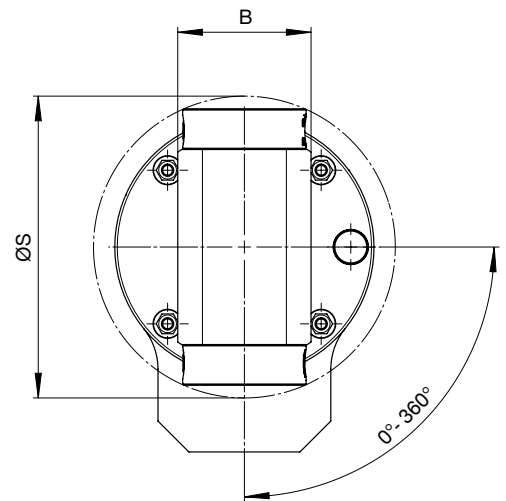
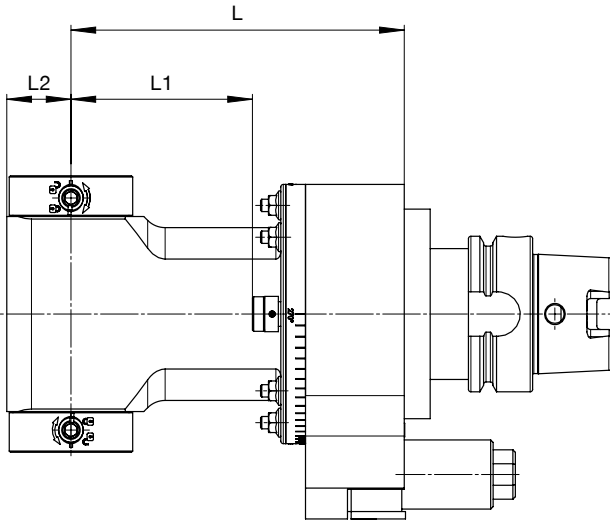

Size 04		► Technical data							
		L1 [mm]	L2 [mm]	B [mm]	ØS [mm]	L [mm]	EC*	IC	Weight [kg]
M _{max}	= 15 Nm	43.5				95			4
i	= 1:1	93.5	24	46	107	145	-	-	4.3
n _{max}	= 10,000 rpm	123.5				175			4.5

Size 05		► Technical data							
		L1 [mm]	L2 [mm]	B [mm]	ØS [mm]	L [mm]	EC*	IC	Weight [kg]
M _{max}	= 30 Nm	26.5				88	-		5
i	= 1:1	73.5	26	54	123	135	- / ✓	-	5.5
n _{max}	= 8,000 rpm	133.5				195	- / ✓		6.5
p _{max}	= 70 bar*								

Size 07		► Technical data							
		L1 [mm]	L2 [mm]	B [mm]	ØS [mm]	L [mm]	EC*	IC	Weight [kg]
M _{max}	= 70 Nm	43.5				105	-		8.5
i	= 1:1	88.5	35	80	157	150	- / ✓	-	9.5
n _{max}	= 6,000 rpm	153.5				215	- / ✓		11
p _{max}	= 70 bar*								

Size 15		► Technical data							
		L1 [mm]	L2 [mm]	B [mm]	ØS [mm]	L [mm]	EC*	IC	Weight [kg]
M _{max}	= 150 Nm	85.5				155	-		14.5
i	= 1:1	155.5	40	92	188	225	- / ✓	-	17
n _{max}	= 4,000 rpm	228.5				298	- / ✓		19.5
p _{max}	= 70 bar*								

Size 20		► Technical data							
		L1 [mm]	L2 [mm]	B [mm]	ØS [mm]	L [mm]	EC*	IC	Weight [kg]
M _{max}	= 230 Nm	101				171	-		16.5
i	= 1:1	171	45	100	205	241	- / ✓	-	19
n _{max}	= 3,000 rpm	241				311	- / ✓		21.5
p _{max}	= 70 bar*								



*Optional: EC via spray nozzle

ANGLE HEAD DUO WZX

▶ OUTPUT SPINDLE / CLAMPING SYSTEM

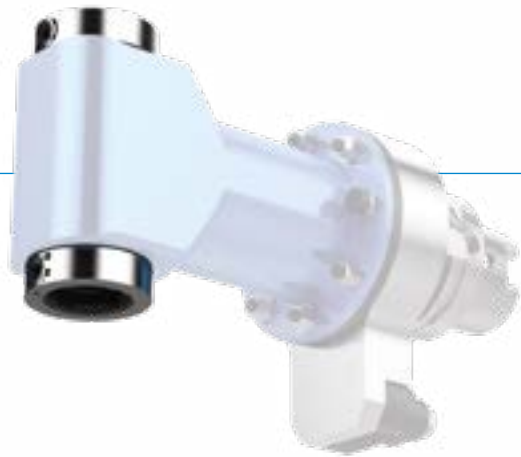

i Technical data for other output spindles / clamping systems on request:



Weldon



Whistle
Notch



KM™

i We show you **preferable sizes** in the following tables. Smaller output spindles are possible at any time as an option.

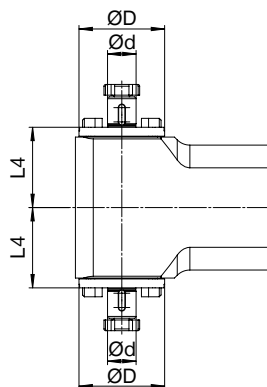
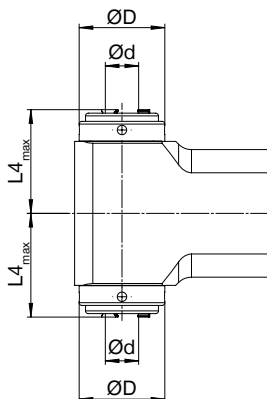

▶ Technical data

Collet chuck	Size	L4 _{max} [mm]	ØD [mm]	Ød _{max} [mm]
ER16A	04	46	44	10
ER20A	04	54	44	13
ER25A	05	57	47	16
ER32A	07	69	55	20
ER40A	15	82	70	30
ER40A	20	82	75	30



▶ Technical data

Milling arbor	Size	L4 [mm]	ØD [mm]	Ød [mm]
22	05	48	48	22
27	07	62.5	60	27
32	15	76	75	32
40	15	77.5	80	40
40	20	77.5	80	40

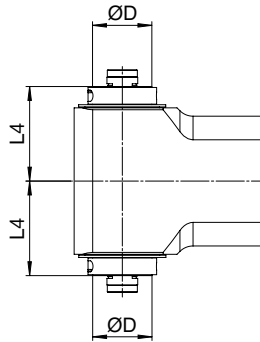
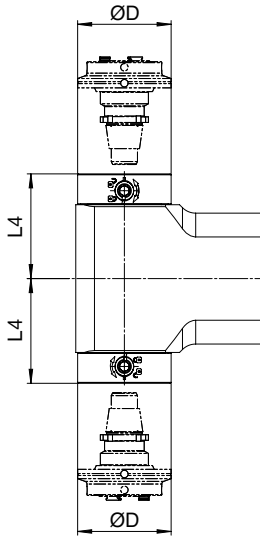

i For adapters and dimensions, see catalogue
BENZ Modular Quick Change Systems



BENZ Solidfix®

▶ Technical data			
Size	L4 [mm]	ØD [mm]	
S2	04	49.5	40
S3	05	56	50
S4	07	72	63
S5	15	86	75
S5	20	90	75



HSK

▶ Technical data			
Size	L4 [mm]	ØD [mm]	
HSK 40	05	59	40
HSK 50	07	68	50
HSK 63	15	93	63
HSK 63	20	99	63

ANGLE HEAD

DUO WZX

► DRIVE CONE

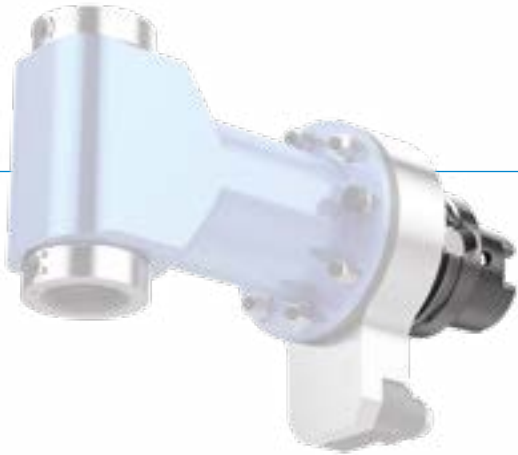

Technical data for other machine interfaces on request.

Type: Steep taper



	► Size				
SK DIN 69871	04	05	07	15	20
SK 40	✓	✓	✓	-	-
SK 50	✓	✓	✓	✓	✓



	► Size				
MAS BT	04	05	07	15	20
BT 40	✓	✓	✓	-	-
BT 50	✓	✓	✓	✓	✓



	► Size				
CAT	04	05	07	15	20
CAT 40	✓	✓	✓	-	-
CAT 50	✓	✓	✓	✓	✓

Type: Hollow shank taper



	▶ Size				
HSK DIN 69893	04	05	07	15	20
HSK 40	✓	-	-	-	-
HSK 50	✓	✓	-	-	-
HSK 63	✓	✓	✓	-	-
HSK 80	✓	✓	✓	✓	-
HSK 100	✓	✓	✓	✓	✓



	▶ Size				
Coromant Capto®	04	05	07	15	20
C3	✓	-	-	-	-
C4	✓	✓	-	-	-
C5	✓	✓	✓	✓	-
C6	✓	✓	✓	✓	✓
C8	✓	✓	✓	✓	✓



	▶ Size				
Kennametal™	04	05	07	15	20
KM 40	✓	-	-	-	-
KM 50	✓	✓	-	-	-
KM 63	✓	✓	✓	-	-
KM 80	✓	✓	✓	✓	-
KM 100	✓	✓	✓	✓	✓

ANGLE HEAD FORTE WWX

► MODULAR DESIGN



► ANGLE HEAD BODY (SIZE)

05

07

15

20

► OUTPUT SPINDLE / CLAMPING SYSTEM



BENZ
Solidfix®



BENZ
CAPTO™



Collet chuck



HSK



Milling arbor



Weldon



Whistle
Notch



KM™

► DRIVE CONE



SK
DIN 69871



MAS BT



CAT



HSK
DIN 69893



Coromant
Capto®



KM™

► Specifications

Change the
angle head



Machining



Number of
output spindles



Axis angle



Coolant supply



FORTE WWX

► Angle head without IC

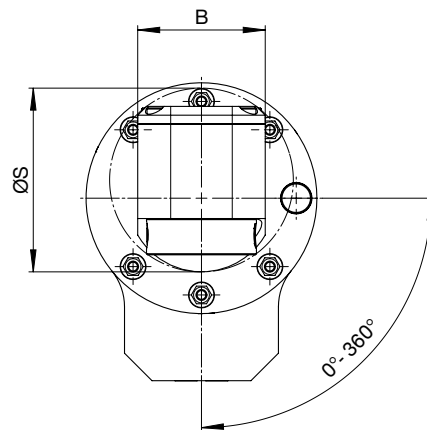
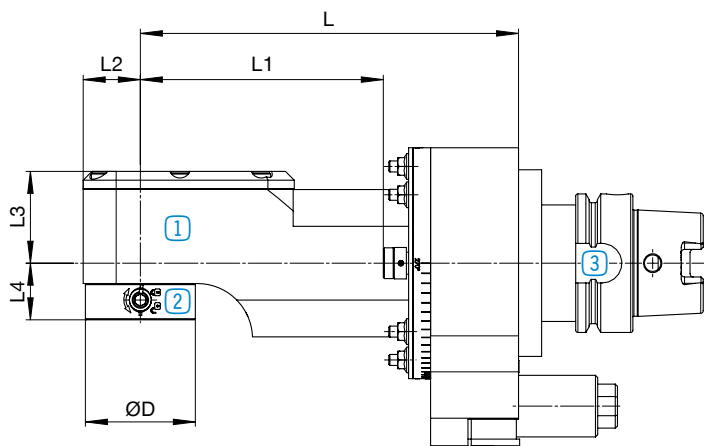

► Angle head with IC

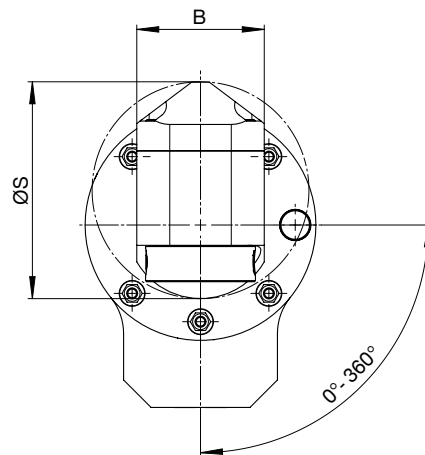
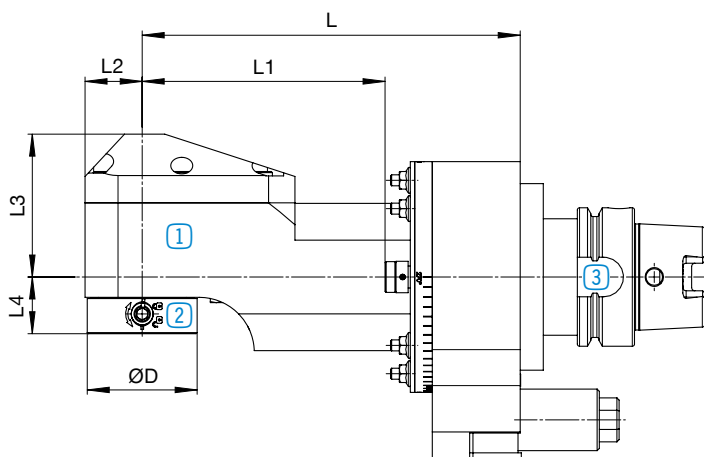

1 Angle head body
Page 38



2 Output spindle /
Clamping system
Page 40



3 Drive cone
Page 42

i Other dimensions for angle heads with BENZ CAPTO™ output spindle. Dimensions available on request.

ANGLE HEAD FORTE WWX

▶ ANGLE HEAD BODY (SIZE)



More sizes on request.
Higher speeds are possible as an option.

▶ Angle head without IC

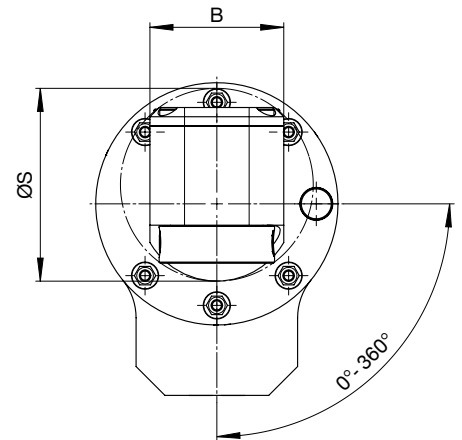
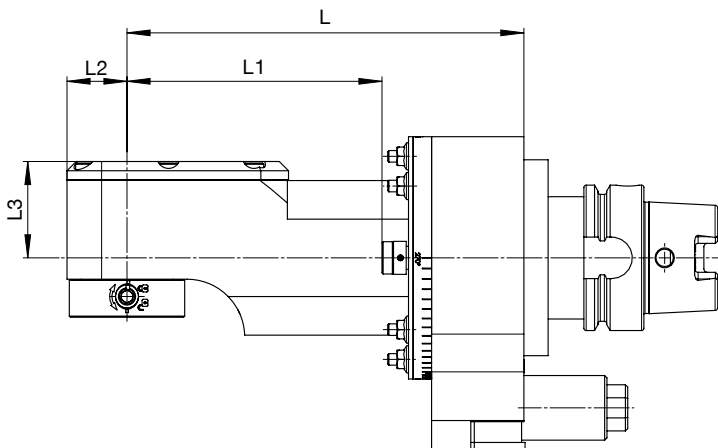

▶ Angle head with IC

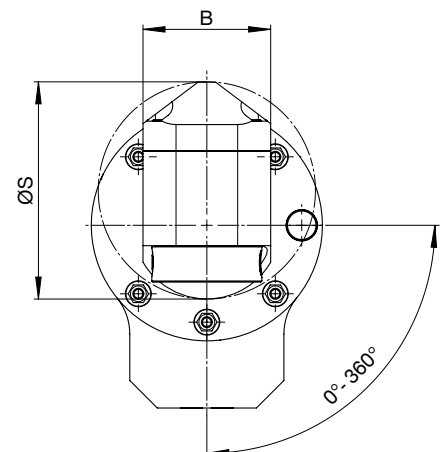
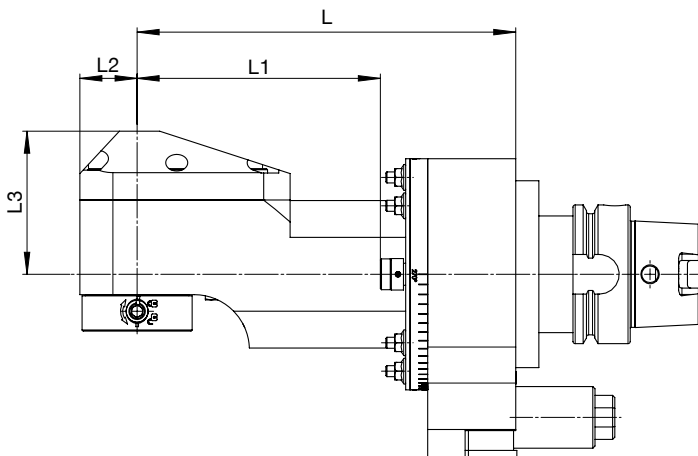

Size 05		► Technical data											
		L1 [mm]	L2 [mm]	L3 [mm]		B [mm]	ØS [mm]		L [mm]	EC*	IC	EC+IC	Weight [kg]
M_{max}	= 30 Nm	63.5		EC	IC		EC	IC	125	- / ✓	- / ✓	✓	5
i	= 1:1	110.5	26	42	65	58	84	81	172	- / ✓	- / ✓	✓	6
n_{max}	= 8,000 rpm	170.5							232	- / ✓	- / ✓	✓	7
p_{max}	= 100 bar												

Size 07		► Technical data											
		L1 [mm]	L2 [mm]	L3 [mm]		B [mm]	ØS [mm]		L [mm]	EC*	IC	EC+IC	Weight [kg]
M_{max}	= 70 Nm	93.5		EC	IC		EC	IC	155	- / ✓	- / ✓	✓	8.5
i	= 1:1	138.5	35	55	77	70	109	122	200	- / ✓	- / ✓	✓	9.5
n_{max}	= 6,000 rpm	191.5							253	- / ✓	- / ✓	✓	10.5
p_{max}	= 100 bar												

Size 15		► Technical data											
		L1 [mm]	L2 [mm]	L3 [mm]		B [mm]	ØS [mm]		L [mm]	EC*	IC	EC+IC	Weight [kg]
M_{max}	= 150 Nm	125.5		EC	IC		EC	IC	195	- / ✓	- / ✓	✓	14
i	= 1:1	162.5	40	66	88.5	90	129	139	232	- / ✓	- / ✓	✓	15
n_{max}	= 4,000 rpm	262.5							332	- / ✓	- / ✓	✓	17.5
p_{max}	= 100 bar												

Size 20		► Technical data											
		L1 [mm]	L2 [mm]	L3 [mm]		B [mm]	ØS [mm]		L [mm]	EC*	IC	EC+IC	Weight [kg]
M_{max}	= 230 Nm	135.5		EC	IC		EC	IC	200	- / ✓	- / ✓	✓	17
i	= 1:1	172.5	45	65.5	88.5	90	130	141	237	- / ✓	- / ✓	✓	18
n_{max}	= 3,000 rpm	272.5							337	- / ✓	- / ✓	✓	21.5
p_{max}	= 100 bar												



*Optional: EC via spray nozzle

ANGLE HEAD

FORTE WWX

▶ OUTPUT SPINDLE / CLAMPING SYSTEM



i Technical data for other output spindles / clamping systems on request:



Weldon



Whistle
Notch



KM™

i We show you **preferable sizes** in the following tables. Smaller output spindles are possible at any time as an option.

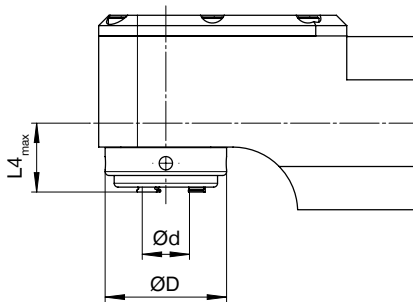

▶ Technical data

	Size	L4 _{max} [mm]		ØD [mm]	Ød _{max} [mm]
		EC	IC		
Collet chuck					
ER25A	05	20.75	25.75	47	16
ER32A	07	23.9	28.9	55	20
ER40A	15	31	35.9	70	30
ER40A	20	31	41.6	75	30

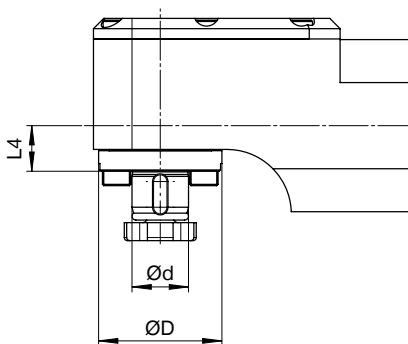

▶ Technical data

	Size	L4 [mm]	ØD [mm]		Ød [mm]
			EC	IC	
Milling arbor					
22	05	17.75	48	22	
27	07	21.5	60	27	
32	15	32.5	75	32	
32	20	32.5	75	32	

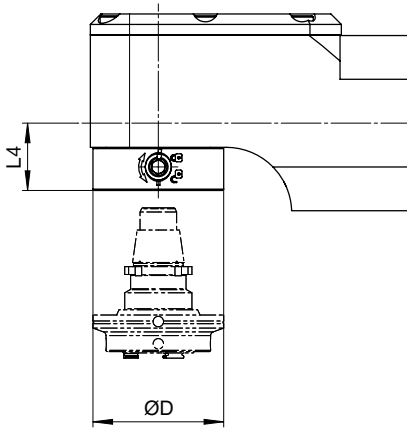

i For adapters and dimensions, see catalogue **BENZ Modular Quick Change Systems**



► **Technical data**

	Size	L4 [mm]		ØD [mm]
		EC	IC	
BENZ Solidfix®				
S3	05	25.75		50
S4	07	31		63
S5	15	35.5		75
S5	20	39.5		75

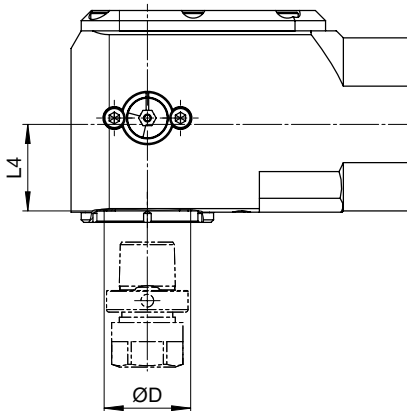

i For adapters and dimensions, see catalogue **BENZ Modular Quick Change Systems**



► **Technical data**

	Size	L4 [mm]		ØD [mm]
		EC	IC	
BENZ CAPTO™				
C3	05	34		32
C4	07	32		40
C5	15	39		50
C6	20	58		63

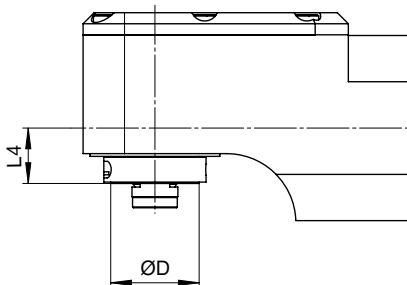

► **Technical data**

	Size	L4 [mm]		ØD [mm]
		EC	IC	
HSK				
HSK 32	05	20		32
HSK 40	07	24		40
HSK 50	15	35		50
HSK 63	15	42		63
HSK 63	20	40		63

ANGLE HEAD FORTE WWX

► DRIVE CONE



Technical data for other machine interfaces on request.

Type: Steep taper



SK
DIN 69871

► Size

	05	07	15	20
SK 40	✓	✓	-	-
SK 50	✓	✓	✓	✓



MAS BT

► Size

	05	07	15	20
BT 40	✓	✓	-	-
BT 50	✓	✓	✓	✓



CAT

► Size

	05	07	15	20
CAT 40	✓	✓	-	-
CAT 50	✓	✓	✓	✓

Type: Hollow shank taper



	▶ Size			
HSK DIN 69893	05	07	15	20
HSK 40	-	-	-	-
HSK 50	✓	-	-	-
HSK 63	✓	✓	-	-
HSK 80	✓	✓	✓	-
HSK 100	✓	✓	✓	✓



	▶ Size			
Coromant Capto®	05	07	15	20
C3	-	-	-	-
C4	✓	-	-	-
C5	✓	✓	✓	-
C6	✓	✓	✓	✓
C8	✓	✓	✓	✓



	▶ Size			
Kennametal™	05	07	15	20
KM 40	-	-	-	-
KM 50	✓	-	-	-
KM 63	✓	✓	-	-
KM 80	✓	✓	✓	-
KM 100	✓	✓	✓	✓

ANGLE HEAD

SLIM WGX

► MODULAR DESIGN



► ANGLE HEAD BODY (SIZE)

05

07

► OUTPUT SPINDLE / CLAMPING SYSTEM



BENZ
Solidfix®



Collet chuck

► DRIVE CONE



SK
DIN 69871



MAS BT



CAT



HSK
DIN 69893



Coromant
Capto®



KM™

► Specifications

Change the
angle head



Machining



Number of
output spindles



Axis angle



Coolant supply



Option

SLIM WGX

► Angle head without IC

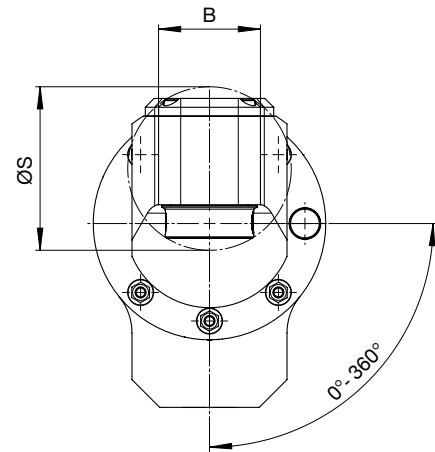
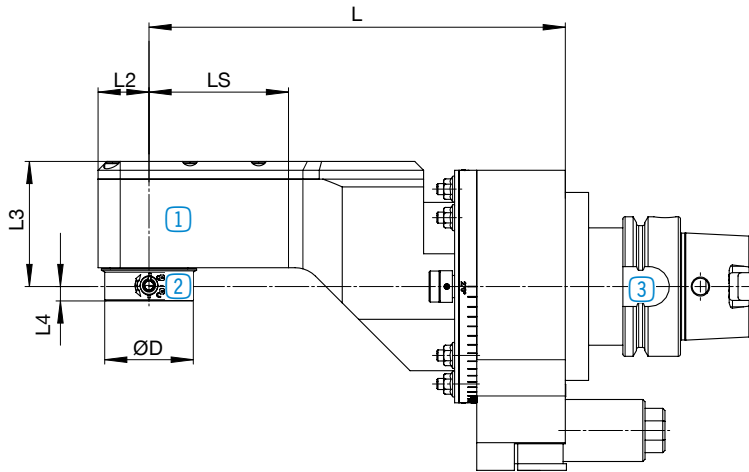

1 Angle head body
Page 46

extremely narrow
design
Page 50



2 Output spindle /
Clamping system
Page 48



3 Drive cone
Page 54

ANGLE HEAD

SLIM WGX

▶ ANGLE HEAD BODY (SIZE)

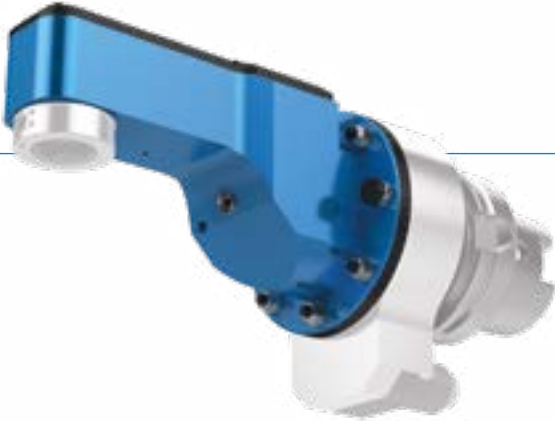

More sizes on request.
Higher speeds are possible as an option.

▶ Angle head without IC

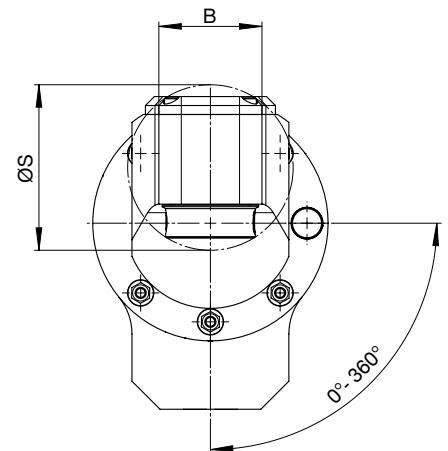
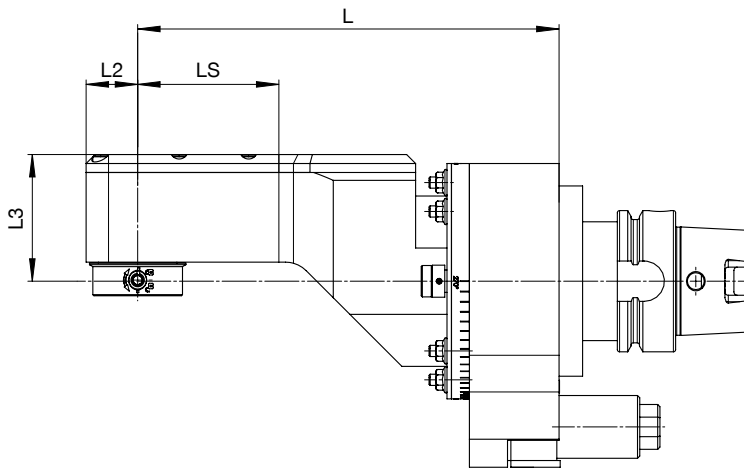

Size 05 / L2=16		▶ Technical data								
		LS [mm]	L2 [mm]	L3 [mm]	B [mm]	ØS [mm]	L [mm]	EC*	IC	Weight [kg]
$M_{2\max}$	= 12 Nm	24.2					149.2	- / ✓		5
i	= 1:1,607	56.2	16	56	40	63	181.2	- / ✓	-	5.2
$n_{2\max}$	= 8,000 rpm	88.2					213.2	- / ✓		5.4
p_{\max}	= 100 bar									

Size 05 / L2=18		▶ Technical data								
		LS [mm]	L2 [mm]	L3 [mm]	B [mm]	ØS [mm]	L [mm]	EC*	IC	Weight [kg]
$M_{2\max}$	= 15 Nm	25.4					150.4	- / ✓		5.2
i	= 1:1,452	57.4	18	58.5	40	71	182.4	- / ✓	-	5.3
$n_{2\max}$	= 8,000 rpm	89.4					213.4	- / ✓		5.4
p_{\max}	= 100 bar									

Size 05 / L2=23		▶ Technical data								
		LS [mm]	L2 [mm]	L3 [mm]	B [mm]	ØS [mm]	L [mm]	EC*	IC	Weight [kg]
M_{\max}	= 15 Nm	31					156	- / ✓		5.4
i	= 1:1	63	23	56.5	46	74	188	- / ✓	-	5.5
n_{\max}	= 8,000 rpm	95					220	- / ✓		5.7
p_{\max}	= 100 bar									

Size 07		▶ Technical data								
		LS [mm]	L2 [mm]	L3 [mm]	B [mm]	ØS [mm]	L [mm]	EC*	IC	Weight [kg]
M_{\max}	= 35 Nm	54					178	- / ✓		9
i	= 1:1	85	26	65	52	78	215	- / ✓	-	9.5
n_{\max}	= 6,000 rpm	160					290	- / ✓		10
p_{\max}	= 100 bar									



*Optional: EC via spray nozzle



$M_{2\max}$ = output torque
 $n_{2\max}$ = output speed

ANGLE HEAD

SLIM WGX

▶ OUTPUT SPINDLE / CLAMPING SYSTEM

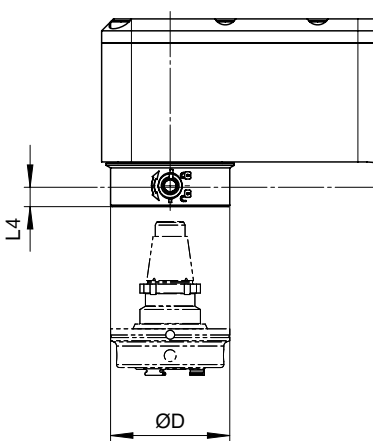
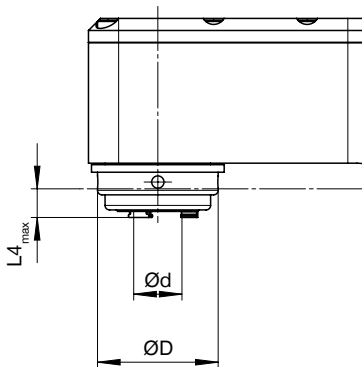

For adapters and dimensions, see catalogue **BENZ Modular Tool Systems**



▶ Technical data

Collet chuck	Size	L4 _{max} [mm]	ØD [mm]	Ød _{max} [mm]
ER11A	05 (L2=16)	1	30	7
ER16A	05 (L2=18)	7	44	10
ER20A	05 (L2=23)	10	44	13
ER25A	07	4	47	16



▶ Technical data

BENZ Solidfix®	Size	L4 [mm]	ØD [mm]
S2	05 (L2=23)	6.5	40
S3	07	2.5	50



ANGLE HEAD SLIM WGX-S

▶ EXTREMELY NARROW DESIGN

▶ Angle head without IC

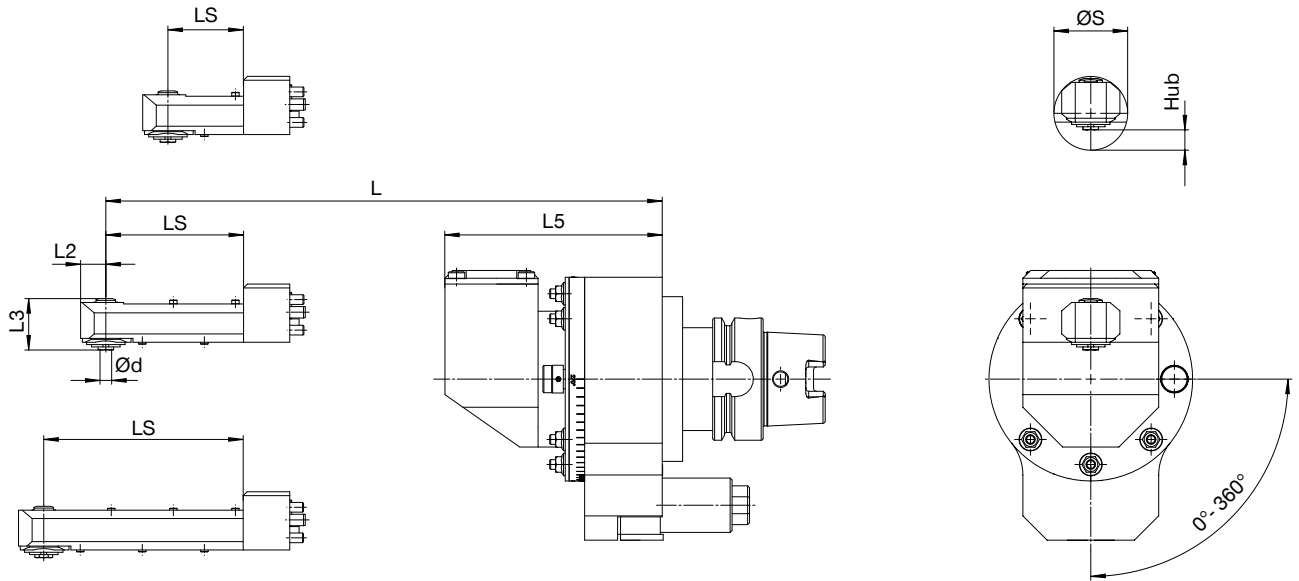

		▶ Technical data										
Size 05 / ØS=25		LS [mm]	L2 [mm]	L3 [mm]	L5 [mm]	Ød [mm]	ØS [mm]	L [mm]	Hub [mm]	EC*	IC	Weight [kg]
$M_{2\max}$	= 3 Nm	31						167		- / ✓		3.7
i	= 1:2,38	57	12.5	20	112	4	25	193	4	- / ✓	-	3.8
$n_{2\max}$	= 8,000 rpm					Special						
p_{\max}	= 100 bar	96						232		- / ✓		3.9

		▶ Technical data										
Size 05 / ØS=29		LS [mm]	L2 [mm]	L3 [mm]	L5 [mm]	Ød [mm]	ØS [mm]	L [mm]	Hub [mm]	EC*	IC	Weight [kg]
$M_{2\max}$	= 3 Nm	32						168		- / ✓		3.8
i	= 1:2,19	71	13.5	20	112	4	29	207	6	- / ✓	-	3.9
$n_{2\max}$	= 8,000 rpm					Special						
p_{\max}	= 100 bar	97						233		- / ✓		4.0

		▶ Technical data										
Size 05 / ØS=32		LS [mm]	L2 [mm]	L3 [mm]	L5 [mm]	Ød [mm]	ØS [mm]	L [mm]	Hub [mm]	EC*	IC	Weight [kg]
$M_{2\max}$	= 5 Nm	37						173		- / ✓		3.8
i	= 1:2,273	69	12	26,5	112	5	32	205	9	- / ✓	-	4
$n_{2\max}$	= 8,000 rpm					Special						
p_{\max}	= 100 bar	95						231		- / ✓		4.2



*Optional: EC via spray nozzle



$M_{2\max}$ = output torque
 $n_{2\max}$ = output speed

► EXTREMELY NARROW DESIGN

► Angle head without EC+IC / Output spindle: Whistle Notch

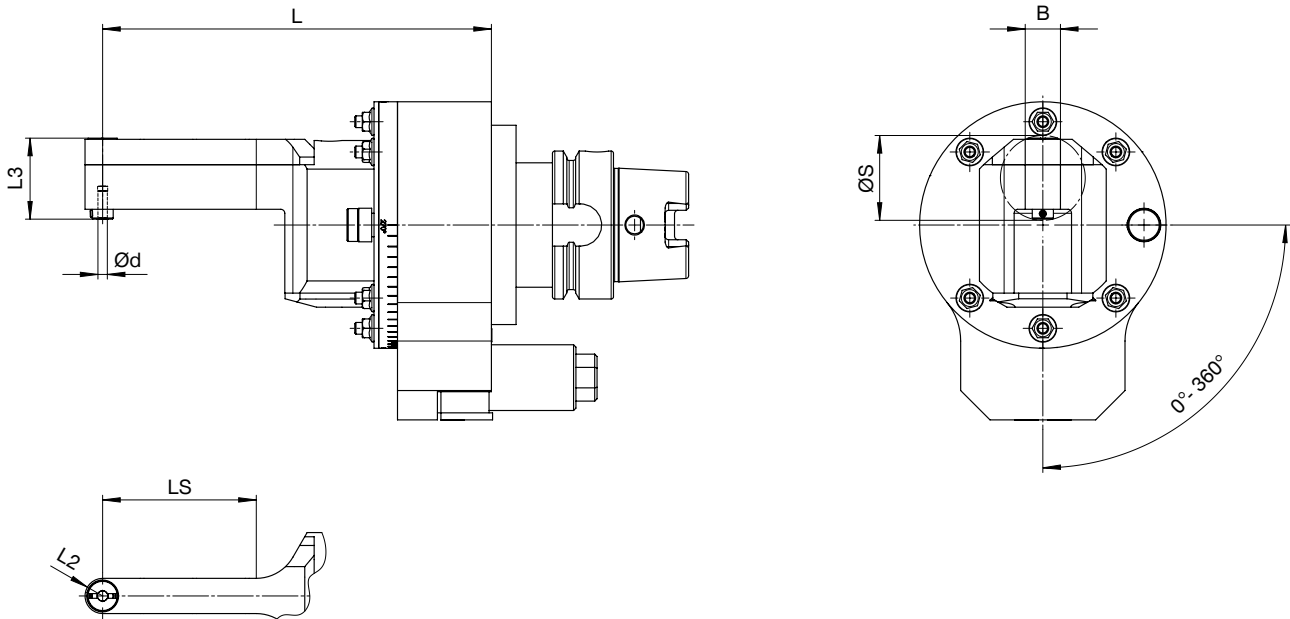

Size 05 / L2=7.5		► Technical data									
		LS [mm]	L2 [mm]	L3 [mm]	Ød [mm]	B [mm]	ØS [mm]	L [mm]	EC	IC	Weight [kg]
$M_{2\max}$	= 3 Nm	66	7.5	34.5	4	15	37	166	-	-	5.4
i	= 1:2,07										
$n_{2\max}$	= 8,000 rpm										
		DIN 1835E									

Size 05 / L2=9.5		► Technical data									
		LS [mm]	L2 [mm]	L3 [mm]	Ød [mm]	B [mm]	ØS [mm]	L [mm]	EC	IC	Weight [kg]
$M_{2\max}$	= 5 Nm	45	9.5	37	6	19	39.4	143	-	-	5.4
i	= 1:1,61										
$n_{2\max}$	= 8,000 rpm										
		DIN 1835E									

i also available with Weldon output spindle

i $M_{2\max}$ = output torque
 $n_{2\max}$ = output speed

ANGLE HEAD

SLIM WGX-S

▶ EXTREMELY NARROW DESIGN

▶ Angle head without IC / Output spindle: Nann-Collet Chuck

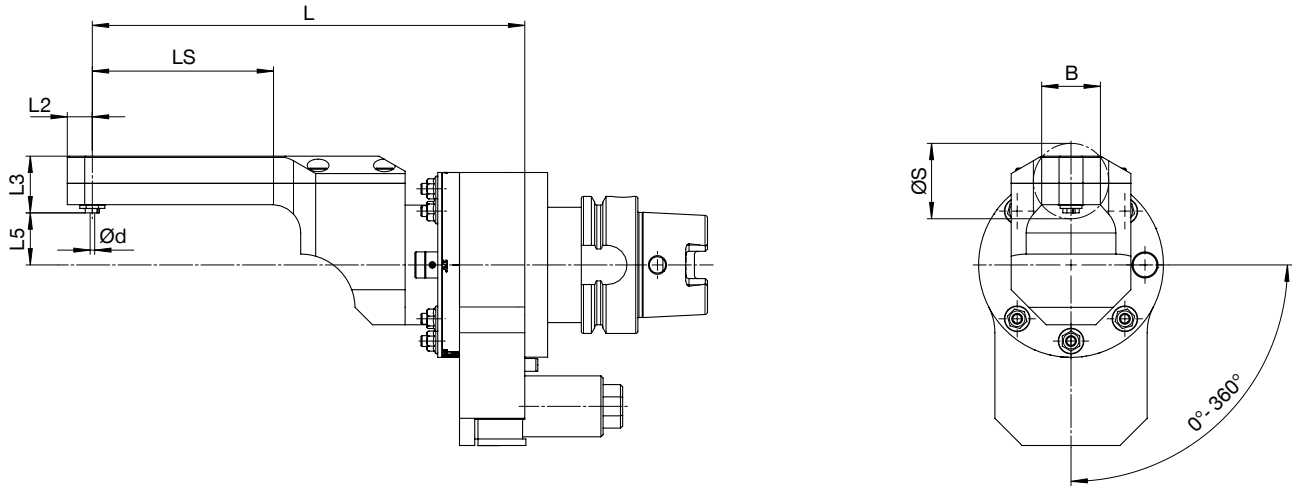

Size 04 / L2=11.5

$M_{2\max}$	= 8 Nm
i	= 1:1,708
$n_{2\max}$	= 10,000 rpm
p_{\max}	= 50 bar

▶ Technical data

LS [mm]	L2 [mm]	L3 [mm]	L5 [mm]	B [mm]	Ød [mm]	ØS [mm]	L [mm]	EC*	IC	Weight [kg]
38.5					4		154	- / ✓		3.7
83	11.5	28	22	27	DIN 6043 E	35	199	- / ✓	-	3.8
128							244	- / ✓		3.9

Size 04 / L2=14

$M_{2\max}$	= 10 Nm
i	= 1:1,367
$n_{2\max}$	= 8,000 rpm
p_{\max}	= 50 bar

▶ Technical data

LS [mm]	L2 [mm]	L3 [mm]	L5 [mm]	B [mm]	Ød [mm]	ØS [mm]	L [mm]	EC*	IC	Weight [kg]
42.5					6		158	- / ✓		3.8
89	14	38	14	30	DIN E603E-3	44	205	- / ✓	-	3.9
135							251	- / ✓		4.1



*Optional: EC via spray nozzle



further Nann-Collet Chucks on request



$M_{2\max}$ = output torque
 $n_{2\max}$ = output speed



ANGLE HEAD

SLIM WGX

► DRIVE CONE



i Technical data for other machine interfaces on request.

Type: Steep taper



	► Size		
SK DIN 69871	04	05	07
SK 40	✓	✓	✓
SK 50	✓	✓	✓



	► Size		
MAS BT	04	05	07
BT 40	✓	✓	✓
BT 50	✓	✓	✓



	► Size		
CAT	04	05	07
CAT 40	✓	✓	✓
CAT 50	✓	✓	✓

Type: Hollow shank taper



	▶ Size		
HSK DIN 69893	04	05	07
HSK 40	✓	-	-
HSK 50	✓	✓	-
HSK 63	✓	✓	✓
HSK 80	✓	✓	✓
HSK 100	✓	✓	✓



	▶ Size		
Coromant Capto®	04	05	07
C3	✓	-	-
C4	✓	✓	-
C5	✓	✓	✓
C6	✓	✓	✓
C8	✓	✓	✓



	▶ Size		
Kennametal™	04	05	07
KM 40	✓	-	-
KM 50	✓	✓	-
KM 63	✓	✓	✓
KM 80	✓	✓	✓
KM 100	✓	✓	✓

ANGLE HEAD

FIX WFX

► MODULAR DESIGN



► ANGLE HEAD BODY (SIZE)

05

07

15

20

► OUTPUT SPINDLE / CLAMPING SYSTEM



BENZ
Solidfix®



BENZ
CAPTO™



Collet chuck



HSK



Milling arbor



Weldon



Whistle
Notch



KM™

► DRIVE CONE



SK
DIN 69871



MAS BT



CAT



HSK
DIN 69893



Coromant
Capto®



KM™

► Specifications

Change the
angle head



Machining



Number of
output spindles



Axis angle



Coolant supply



FIX WFX

► Angle head with IC

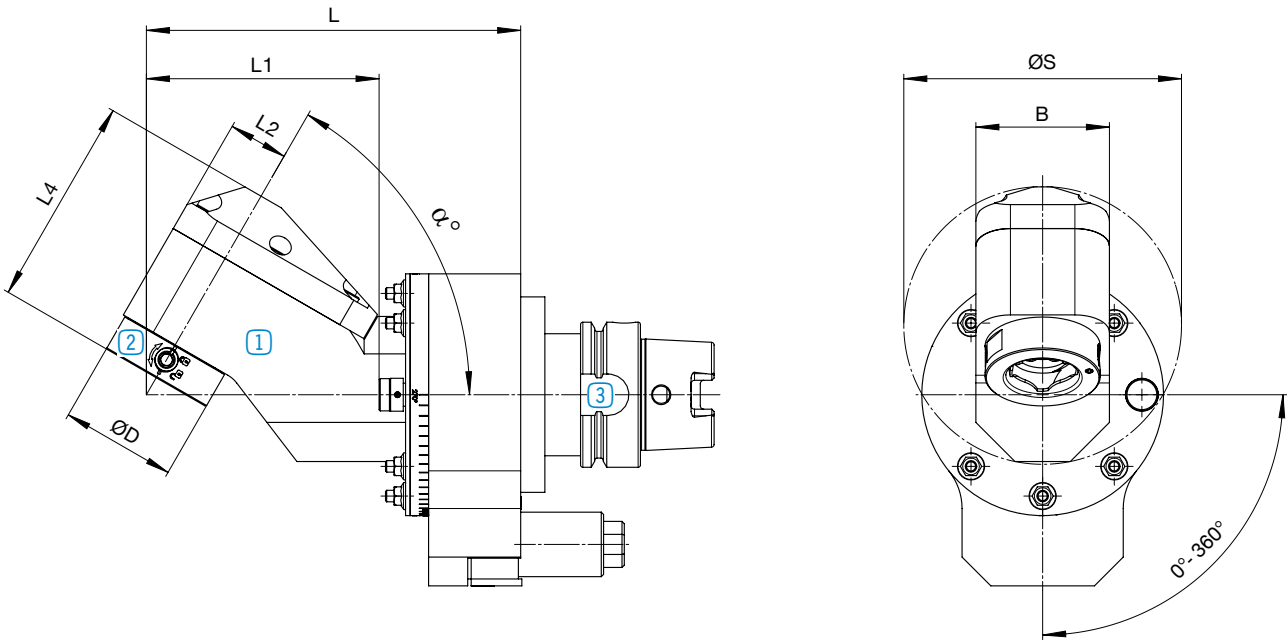

1 Angle head body
Page 58



2 Output spindle /
Clamping system
Page 60



3 Drive cone
Page 62

i Other dimensions for angle heads with BENZ CAPTO™ output spindle. Dimensions available on request.

ANGLE HEAD FIX WFX

▶ ANGLE HEAD BODY (SIZE)



More sizes on request.
Higher speeds are possible as an option.

▶ Angle head with IC

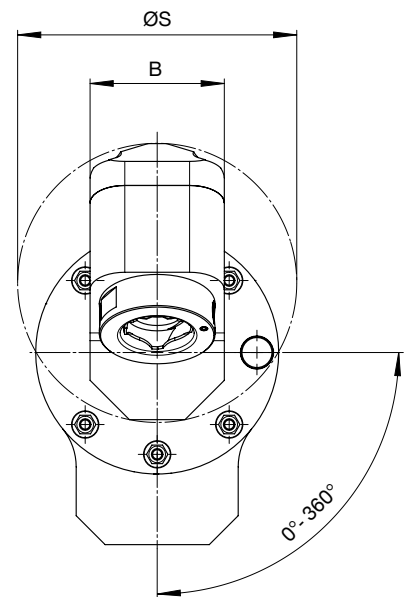
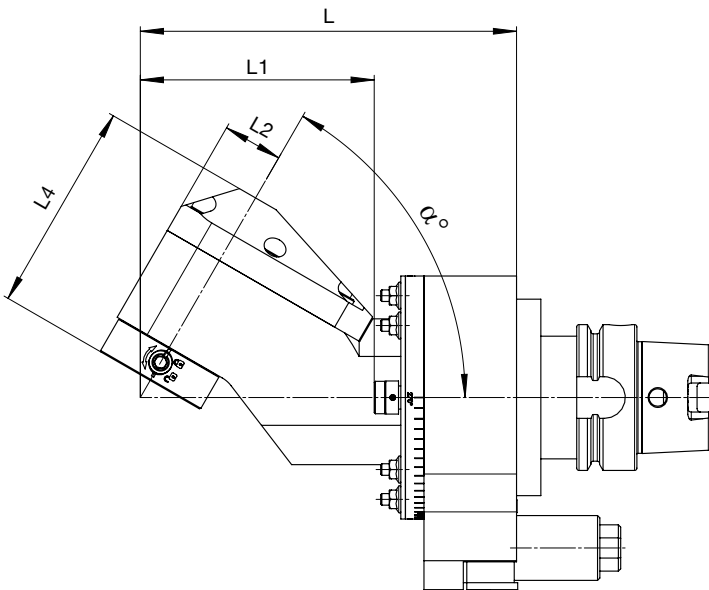

Size 05		▶ Technical data										
		α [°]	L1 [mm]	L2 [mm]	L4* [mm]	B [mm]	ØS [mm]	L** [mm]	EC	IC	EC+IC	Weight [kg]
M_{max}	= 30 Nm	0-120	138	26	91	54	approx. 108	approx. 200	- / ✓	- / ✓	✓	4
i	= 1:1											
n_{max}	= 8,000 rpm											
p_{max}	= 100 bar											

Size 07		▶ Technical data										
		α [°]	L1 [mm]	L2 [mm]	L4* [mm]	B [mm]	ØS [mm]	L** [mm]	EC	IC	EC+IC	Weight [kg]
M_{max}	= 70 Nm	0-120	163	35	108	80	approx. 141	approx. 225	- / ✓	- / ✓	✓	9.5
i	= 1:1											
n_{max}	= 6,000 rpm											
p_{max}	= 100 bar											

Size 15		▶ Technical data										
		α [°]	L1 [mm]	L2 [mm]	L4* [mm]	B [mm]	ØS [mm]	L** [mm]	EC	IC	EC+IC	Weight [kg]
M_{max}	= 150 Nm	0-120	165	40	125	92	approx. 170	approx. 235	- / ✓	- / ✓	✓	13
i	= 1:1											
n_{max}	= 4,000 rpm											
p_{max}	= 100 bar											

Size 20		▶ Technical data										
		α [°]	L1 [mm]	L2 [mm]	L4* [mm]	B [mm]	ØS [mm]	L** [mm]	EC	IC	EC+IC	Weight [kg]
M_{max}	= 230 Nm	0-120	180	40	125	100	approx. 182	approx. 250	- / ✓	- / ✓	✓	16
i	= 1:1											
n_{max}	= 3,000 rpm											
p_{max}	= 100 bar											

i *Value refers to an angle head with BENZ Solidfix® output spindle
 **depending on angle α

ANGLE HEAD FIX WFX

▶ OUTPUT SPINDLE / CLAMPING SYSTEM



i Technical data for other output spindles / clamping systems on request:



Weldon



Whistle
Notch



KM™

i We show you **preferable sizes** in the following tables. Smaller output spindles are possible at any time as an option.

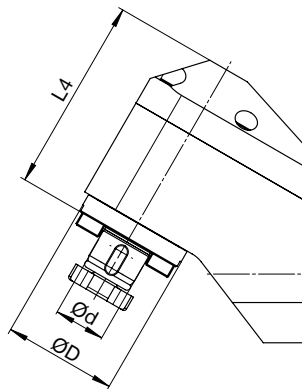
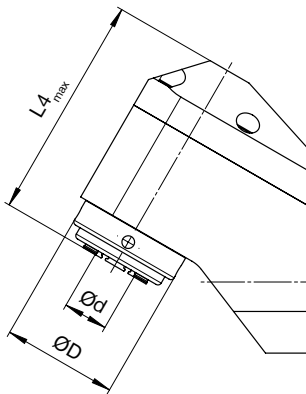

▶ Technical data

Collet chuck	Size	L4 _{max} [mm]	ØD [mm]	Ød _{max} [mm]
ER25A	05	91	47	16
ER32A	07	106	55	20
ER40A	15	125	70	30
ER40A	20	125	70	30



▶ Technical data

Milling arbor	Size	L4 [mm]	ØD [mm]	Ød [mm]
22	05	83	48	22
27	07	98	60	27
32	15	122	75	32
40	15	125	90	40
40	20	129	90	40

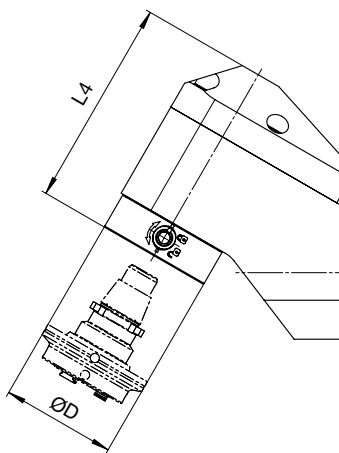

i For adapters and dimensions, see catalogue
BENZ Modular Quick Change Systems



▶ Technical data			
BENZ Solidfix®	Size	L4 [mm]	ØD [mm]
S3	05	91	50
S4	07	108	63
S5	15	125	75
S5	20	128	75

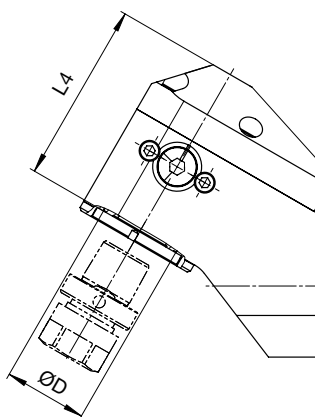

i For adapters and dimensions, see catalogue
BENZ Modular Quick Change Systems



▶ Technical data			
BENZ CAPTO™	Size	L4 [mm]	ØD [mm]
C3	05	100	32
C4	07	108	40
C5	15	129	50
C6	20	148	63

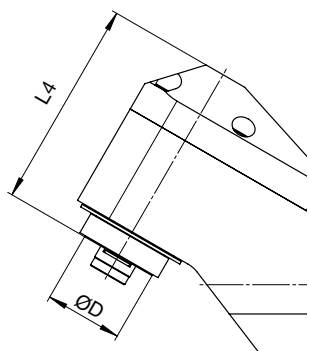

▶ Technical data			
HSK	Size	L4 [mm]	ØD [mm]
HSK 32	05	85	32
HSK 40	07	101	40
HSK 50	15	124	50
HSK 63	15	131	63
HSK 63	20	129	63

ANGLE HEAD

FIX WFX

► DRIVE CONE



Technical data for other machine interfaces on request.

Type: Steep taper



	► Size			
	05	07	15	20
SK DIN 69871				
SK 40	✓	✓	-	-
SK 50	✓	✓	✓	✓



	► Size			
	05	07	15	20
MAS BT				
BT 40	✓	✓	-	-
BT 50	✓	✓	✓	✓



	► Size			
	05	07	15	20
CAT				
CAT 40	✓	✓	-	-
CAT 50	✓	✓	✓	✓

Type: Hollow shank taper



	▶ Size			
HSK DIN 69893	05	07	15	20
HSK 40	-	-	-	-
HSK 50	✓	-	-	-
HSK 63	✓	✓	-	-
HSK 80	✓	✓	✓	✓
HSK 100	✓	✓	✓	✓



	▶ Size			
Coromant Capto®	05	07	15	20
C3	-	-	-	-
C4	✓	-	-	-
C5	✓	✓	✓	✓
C6	✓	✓	✓	✓
C8	✓	✓	✓	✓



	▶ Size			
Kennametal™	05	07	15	20
KM 40	-	-	-	-
KM 50	✓	-	-	-
KM 63	✓	✓	-	-
KM 80	✓	✓	✓	✓
KM 100	✓	✓	✓	✓

ANGLE HEAD

FLEX WDX

► MODULAR DESIGN



► ANGLE HEAD BODY (SIZE)

05

07

15

► OUTPUT SPINDLE / CLAMPING SYSTEM



BENZ
Solidfix®



Collet chuck



HSK



Weldon



Whistle
Notch



KM™

► DRIVE CONE



SK
DIN 69871



MAS BT



CAT



HSK
DIN 69893



Coromant
Capto®



KM™

► Specifications

Change the
angle head



Machining



Number of
output spindles



Axis angle



Coolant supply



FLEX WDX

► Angle head with IC

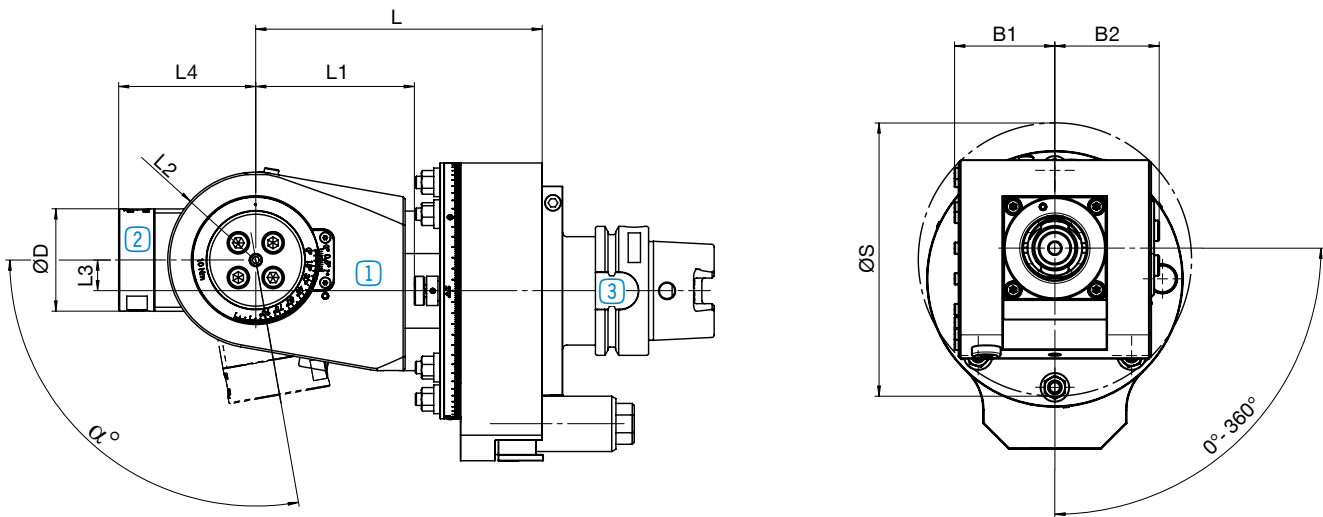

① Angle head body
Page 62



② Output spindle /
Clamping system
Page 64



③ Drive cone
Page 66

ANGLE HEAD

FLEX WDX

▶ ANGLE HEAD BODY (SIZE)



More sizes on request.
Higher speeds are possible as an option.

▶ Angle head with IC

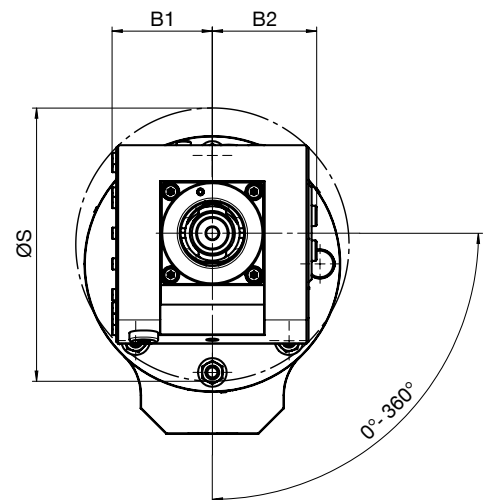
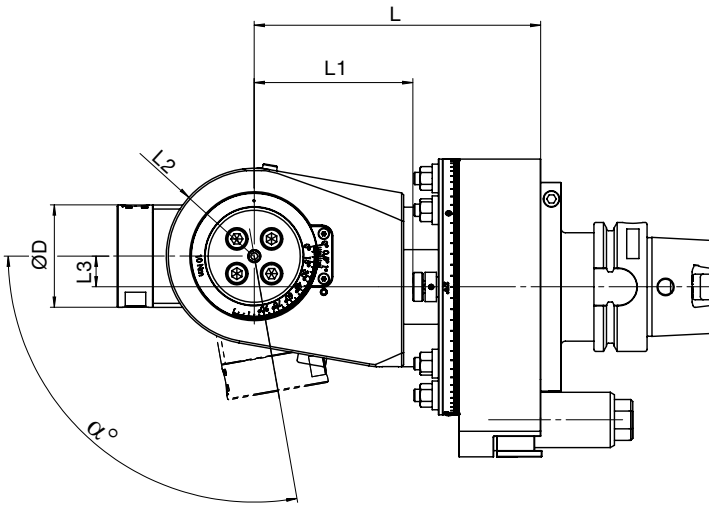

Size 05	
M_{max}	= 20 Nm
i	= 1:1
n_{max}	= 8,000 rpm
p_{max}	= 100 bar

▶ Technical data												
α [°]	L1 [mm]	L2 [mm]	L3 [mm]	B1 [mm]	B2 [mm]	$\varnothing S$ [mm]	L [mm]	EC	IC	EC+IC	Weight [kg]	
0-100	68.5	37	15	46.5	48.5	123	130	- / ✓	- / ✓	✓	7	

Size 07	
M_{max}	= 50 Nm
i	= 1:1
n_{max}	= 6,000 rpm
p_{max}	= 100 bar

▶ Technical data												
α [°]	L1 [mm]	L2 [mm]	L3 [mm]	B1 [mm]	B2 [mm]	$\varnothing S$ [mm]	L [mm]	EC	IC	EC+IC	Weight [kg]	
0-100	77.5	43	15	49	51	134	140	- / ✓	- / ✓	✓	9	

Size 15	
M_{max}	= 90 Nm
i	= 1:1
n_{max}	= 4,000 rpm
p_{max}	= 100 bar

▶ Technical data												
α [°]	L1 [mm]	L2 [mm]	L3 [mm]	B1 [mm]	B2 [mm]	$\varnothing S$ [mm]	L [mm]	EC	IC	EC+IC	Weight [kg]	
0-100	109	50	15	56.5	58.5	156	180	- / ✓	- / ✓	✓	16.5	

ANGLE HEAD

FLEX WDX

▶ OUTPUT SPINDLE / CLAMPING SYSTEM



i Technical data for other output spindles / clamping systems on request:



Weldon



Whistle
Notch



KM™

i We show you **preferable sizes** in the following tables. Smaller output spindles are possible at any time as an option.

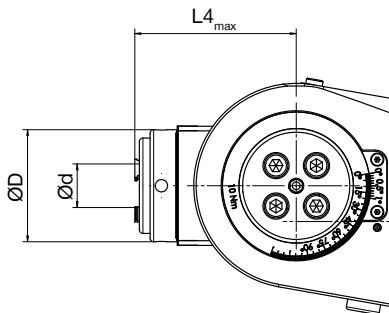

▶ Technical data

Collet chuck	Size	L4 _{max} [mm]	ØD [mm]	Ød _{max} [mm]
ER20A	05	62.5	40	16
ER25A	07	71.9	45	20
ER32A	15	73.2	55	30

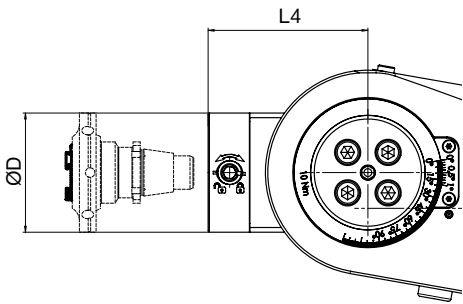

i For adapters and dimensions, see catalogue
BENZ Modular Quick Change Systems



BENZ Solidfix®

S2	05	56	40
S3	07	67	50
S4	15	74	63

▶ Technical data			
Size	L4 [mm]	ØD [mm]	
S2	05	56	40
S3	07	67	50
S4	15	74	63

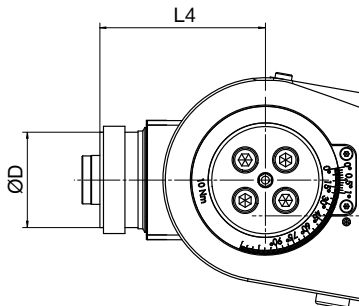

HSK	Size	L4 [mm]	ØD [mm]
HSK 32	05	55	32
HSK 40	07	67	40
HSK 50	15	77	50

▶ Technical data			
Size	L4 [mm]	ØD [mm]	
HSK 32	05	55	32
HSK 40	07	67	40
HSK 50	15	77	50

ANGLE HEAD FLEX WDX

► DRIVE CONE



Technical data for other machine interfaces on request.

Type: Steep taper



SK
DIN 69871

► Size

	05	07	15
SK 40	✓	✓	-
SK 50	✓	✓	✓



MAS BT

► Size

	05	07	15
BT 40	✓	✓	-
BT 50	✓	✓	✓



CAT

► Size

	05	07	15
CAT 40	✓	✓	-
CAT 50	✓	✓	✓

Type: Hollow shank taper



	▶ Size		
HSK DIN 69893	05	07	15
HSK 40	-	-	-
HSK 50	✓	-	-
HSK 63	✓	✓	-
HSK 80	✓	✓	✓
HSK 100	✓	✓	✓



	▶ Size		
Coromant Capto®	05	07	15
C3	-	-	-
C4	✓	-	-
C5	✓	✓	✓
C6	✓	✓	✓
C8	✓	✓	✓



	▶ Size		
Kennametal™	05	07	15
KM 40	-	-	-
KM 50	✓	-	-
KM 63	✓	✓	-
KM 80	✓	✓	✓
KM 100	✓	✓	✓

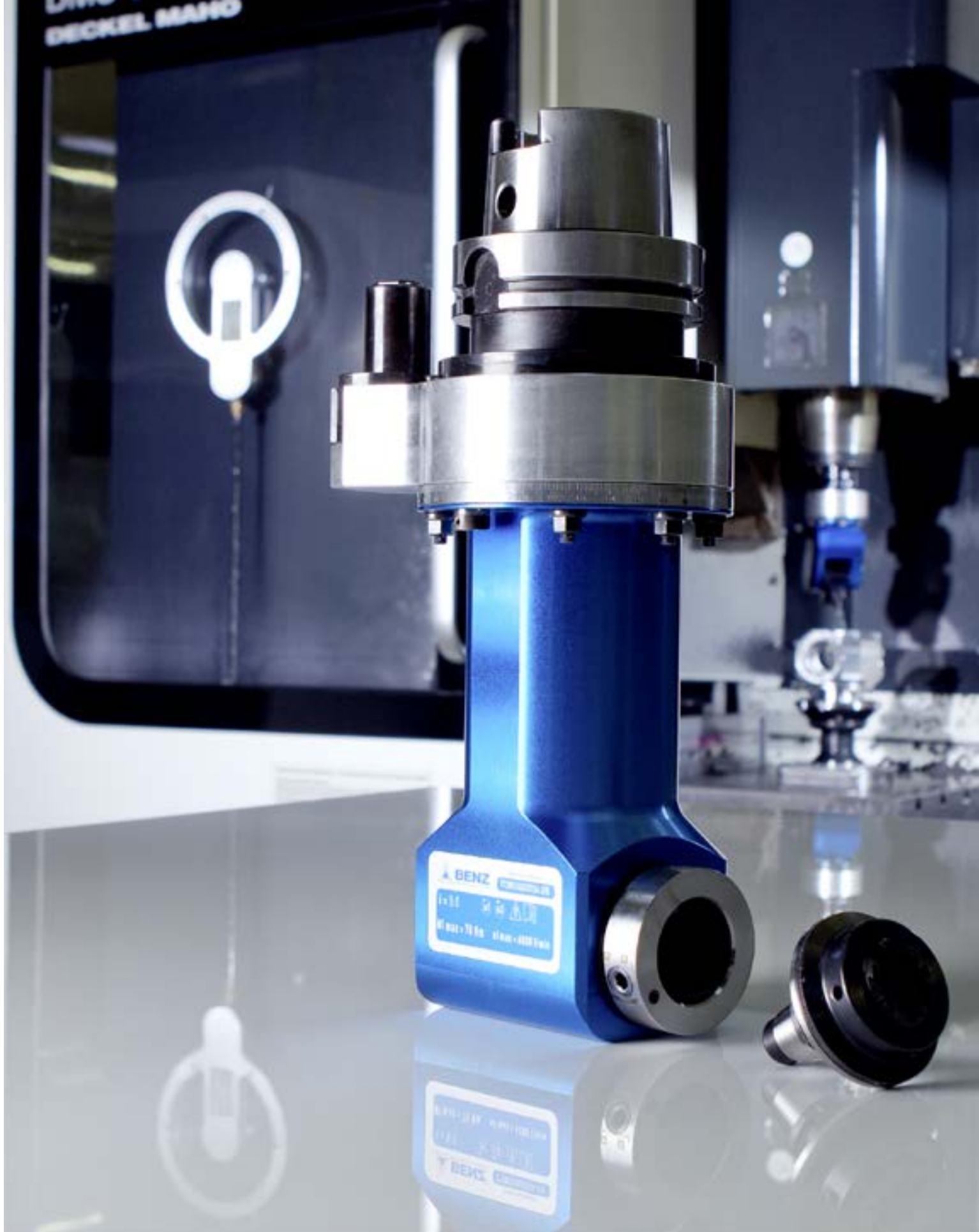



ANGLE HEADS

CUSTOMISED SPECIAL SOLUTIONS

▶ YOUR CUSTOM ANGLE HEAD

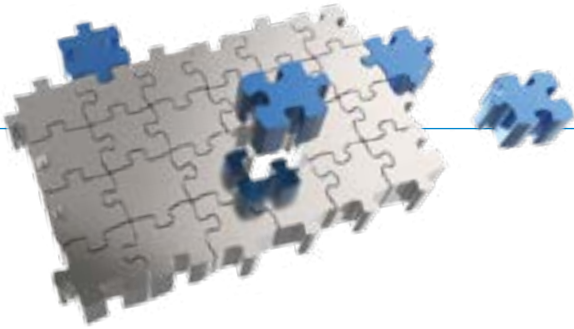

We love the challenge and the exceptional!

- ▶ Do you need an angle head that does not match any standard parameters? No problem! We develop and produce your angle head made to measure exactly according to your specifications. Small adaptations to standard products and highly complex new developments are our strength - prompt, affordable and with the usual BENZ quality thanks to our modular kits. Extreme conditions anywhere in the world: our tried and tested components and systems provide you with limitless possibilities.

FROM THE CUSTOMER REQUIREMENT TO THE INDIVIDUAL SOLUTION



- 1 We define the best possible solution and develop an appropriate concept based on your requirements.



- 2 Your contact partner for construction starts implementation after coordinating the solution proposal.



- 3 Your angle head is a high quality piece of work and is produced and assembled at the BENZ factory by experienced employees.



- 4 Your angle head is subjected to various performance tests before it leaves our factory.



► AUTOMOTIVE EXAMPLES

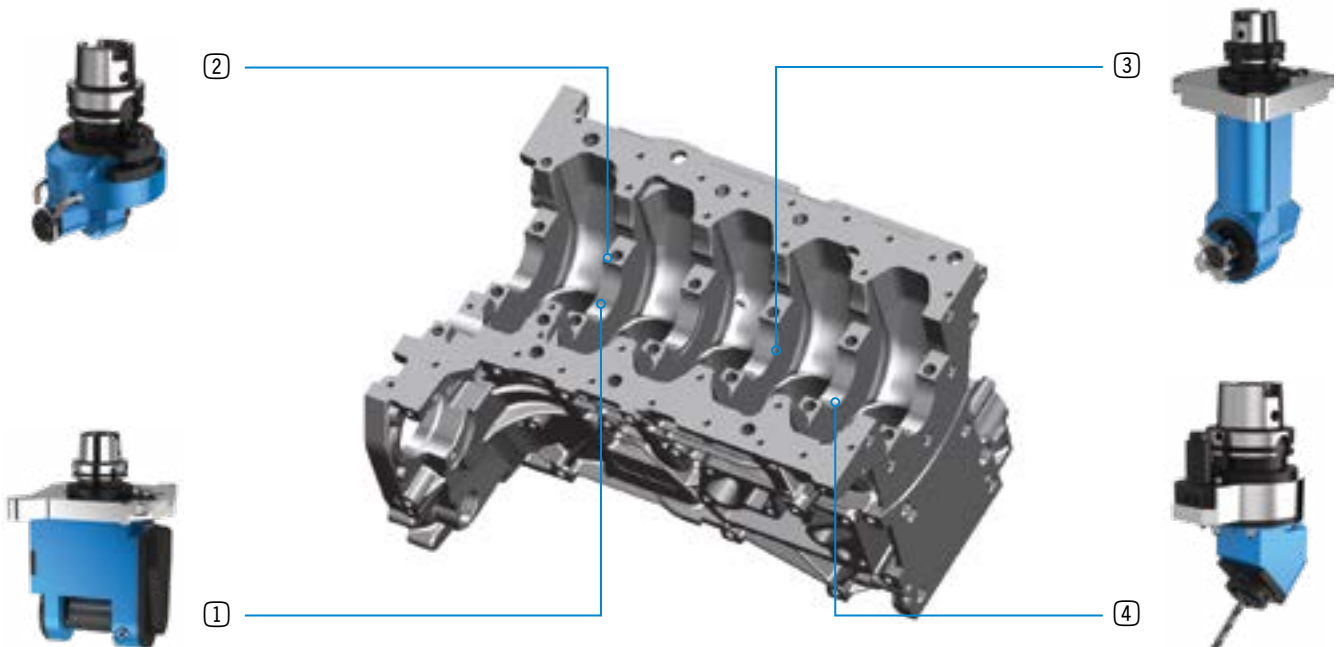

Engine block machining in the automobile industry



Workpiece in detail

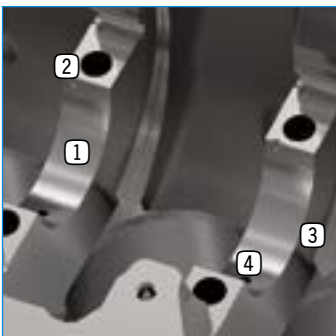

► Automobile industry

1

2

3

4



Bearing shell milling



Retaining slot milling



Side plate milling



Oil hole drilling

More special solutions:



Milling operation for servo housing



Milling operation at rear side of a disc brake



Engine block machining

ANGLE HEADS

CUSTOMISED SPECIAL SOLUTIONS

▶ AEROSPACE EXAMPLES



Engine machining in the aerospace industry



Workpiece in detail



▶ Aerospace

1

2

3



Flange hole drilling



Connection hole drilling



Internal hole drilling

More special solutions:



Oil pan hole



Milling operation at aircraft wheel rims



Connection hole in hydraulic blocks

► WIND POWER EXAMPLES

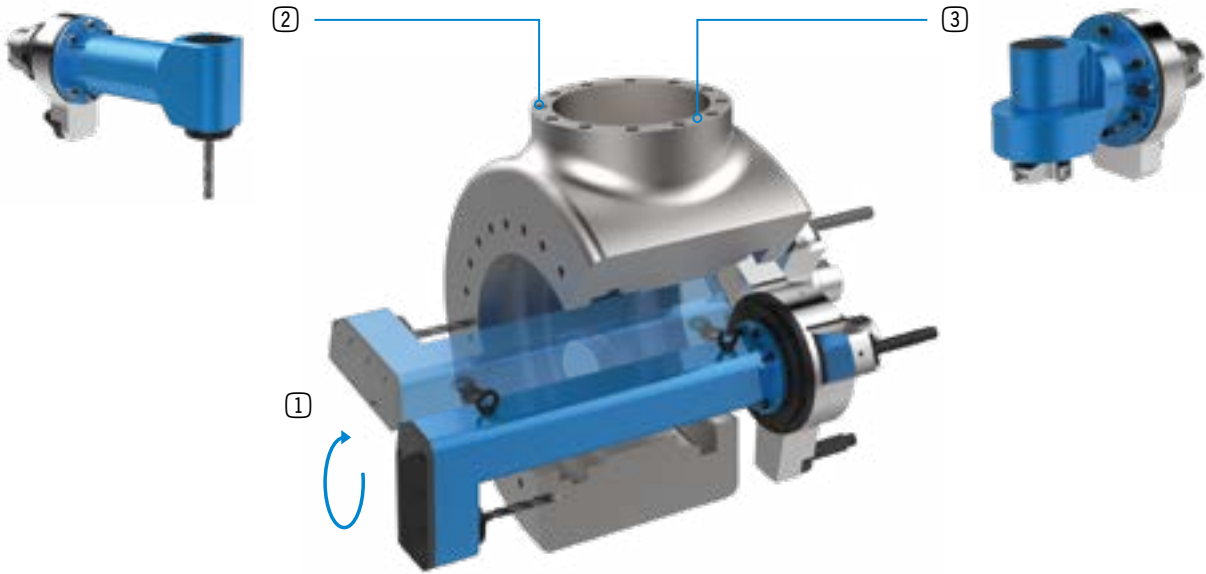

Rotor hub machining in the wind power industry



Workpiece in detail

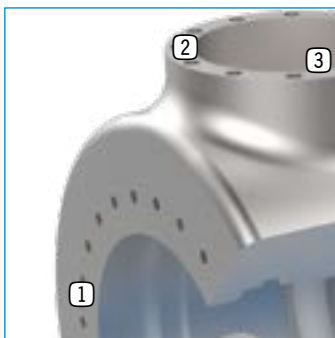

► Wind power

1

2

3



Core hole drilling



Thread tapping



Flange surface milling

More special solutions:



Cross holes with large immersion depth



Milling operations on vertical boring and turning machines

ANGLE HEADS

EQUIPMENT VERSIONS

► COOLANT SUPPLY

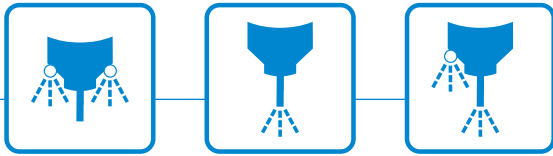

- **Cooling of the tool**
for demanding machining work
- **Various options**
internal cooling, external cooling or a combination of both
- **Cooling lubricant options**
Water, oil, MQL and air

Types of cooling (coolants)

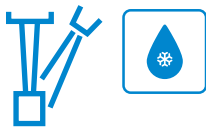

Water cooling

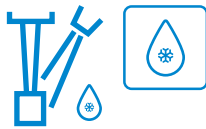

Oil cooling

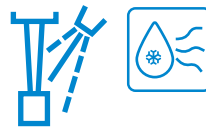

MQL



Air cooling

Coolant supply from the machine

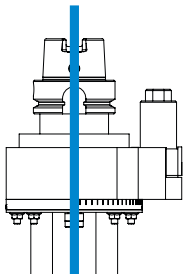

via the spindle

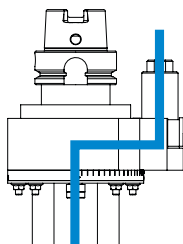

via the stop block

Coolant supply to the cutting edge



EC

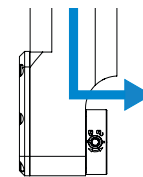

IC

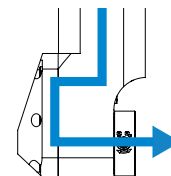

EC+IC

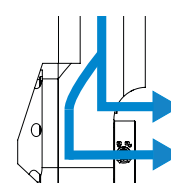

▶ ADDITIONAL SUPPORT



- ▶ **Increased rigidity**
between angle head and machine spindle
- ▶ **Optimum power transmission**
from the machine spindle onto the tool
- ▶ **Improved workpiece quality / service life of the angle head**
due to reduced vibrations

i The need for an additional support depends on the respective machining case. Please contact us. We will be happy to advise you.

Versions



Torque support

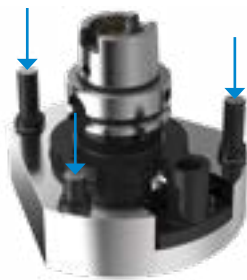

Torque support
with 3-point support

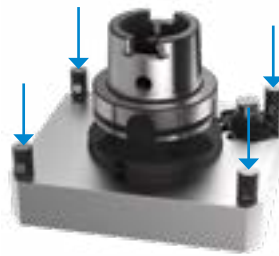

Torque support
with 4-point support



Mechanical/hydraulic
additional support

ANGLE HEADS

EQUIPMENT VERSIONS

▶ LOCK AND UNLOCK BLOCK: STOP BLOCK



- ▶ **Positioning the angle head**
at the machine spindle
- ▶ **Fixing the angle head**
against possible turning
- ▶ **Guarantees a high level of repeat accuracy**
during automatic change of the angle head
- ▶ **ISO 9524 standardised design**

i BENZ stop blocks can be adjusted to the machine by the user. In this case, the hole pattern is provided by the user. For this purpose, please observe our latest angle head operating instructions.

We will be happy to help you with the adjustment of the stop block. Please contact us.

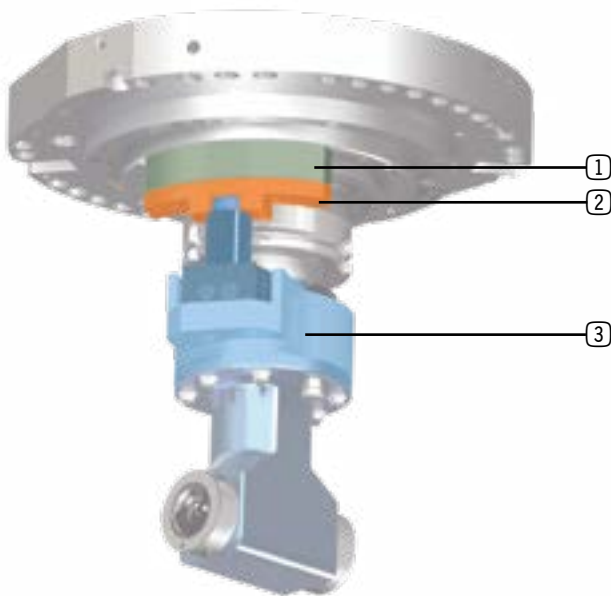

- 1 Spacer block**
 - Regulates the distance between stop block and machine
 - Matched to the specific machine
- 2 Stop block**
 - Locks or unlocks the angle head at the machine spindle
 - The slot at the stop block holds the locking bolt of the torque support
- 3 Torque support**
 - Increases the rigidity between angle head and machine spindle
 - As a rule matched to the specific machine
 - Alternative: BENZ standard torque support

Matching



▶ Stop block / torque support

The torque support of the angle head and the stop block at the machining centre must be matched to each other



▶ Stop block / spacer block

The spacer block must be attached to the machine and adjusted by the customer to set the stop block.

► Standard stop blocks

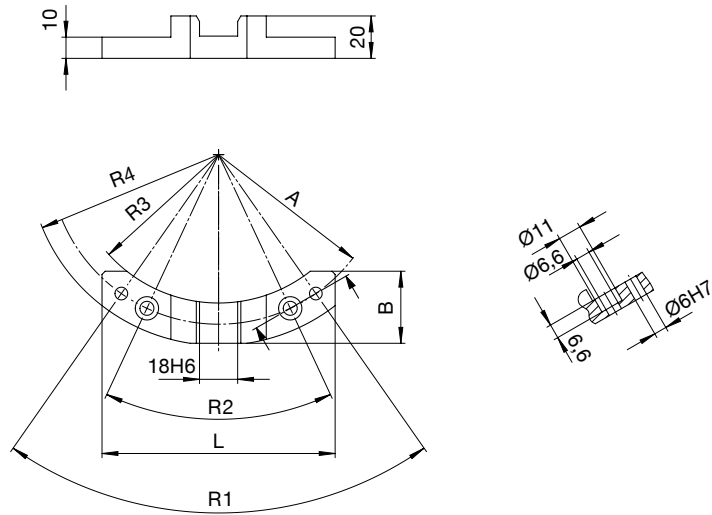
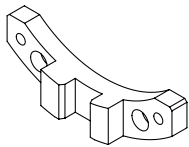

► Technical data

Order No.	A [mm]	R1 [°]	R2 [°]	R3 [°]	R4 [°]	L [mm]	B [mm]
K00600-055/075	65	70	50	R55	R75	90	28
K00600-070/090	80	70	50	R70	R90	110	34
K00600-100/120	110	60	40	R100	R120	130	31

ANGLE HEADS EQUIPMENT VERSIONS



BENZ i.com captures the operating hours of your unit. As additional indicators, speed, temperature and vibrations are recorded and evaluated every 15 seconds. The transparent tool monitoring system recommends service intervals in good time and thus makes it possible to significantly increase the service life of your tool and the reliability of your production. The readout of the operating hours and the operating status is conveniently set via smart device. With the BENZ i.com App you can also contact the BENZ Service directly via e-mail and electronically forward the operating status to it.

Connections to IIoT platforms are also possible. The app also offers access to the cloud, where you can download all the technical documentation for your tool, such as operating instructions, drawings, protocols, etc.

BENEFITS

- Transparent service intervals
- Prevention of unwanted production downtime
- Increased reliability of your production
- Convenient access to drawings, operating instructions and other documents
- Integrated communication with the BENZ Service Team
- Units are ready to be used for Industry 4.0



The BENZ i.com smartphone and tablet application processes your tool data and thereby gives you important information about your unit's status.

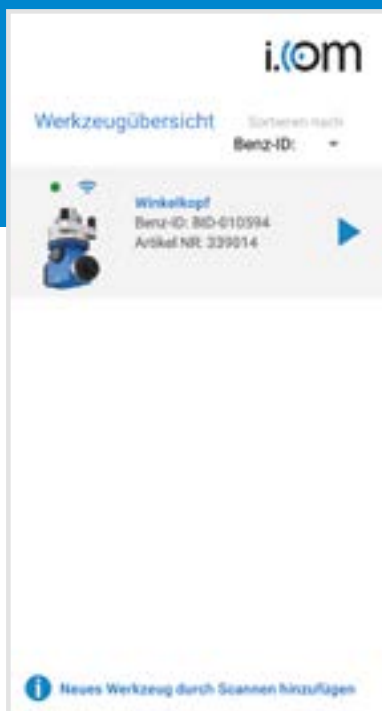

Product view:
Tool data with a preview image.

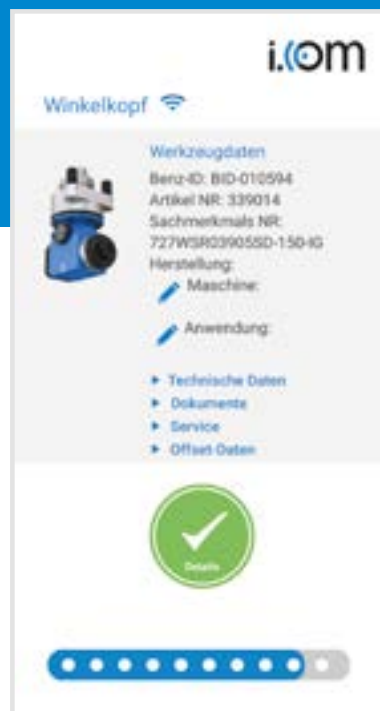

Tool data:
State display with
operating hours counter



Documentation:
Drawings, manuals, protocols
etc. for download



ANGLE HEADS SERVICE

▶ SERVICES: CUSTOMIZED, VALUE-RETAINING, COST-EFFECTIVE



▶ Service repair

Fast and professional analysis of damage
Findings and repair recommendations within 5 working days
on request: general maintenance or refurbishing



▶ ExpressService

Exceptionally fast and efficient turnaround
Repair at a fixed price
48-hour ExpressService available for select units



▶ Individual crash package

Keep machine downtime and lost profits to a minimum
Highly recommended for customer-specific solutions
Includes regular wear and tear as well as special parts



▶ Preventive maintenance

Prevention: Reduce unplanned downtime, increase unit operating times and unit life cycle
Maintain proper product performance / general maintenance or refurbishing
Replacement of wear parts during your planned downtime



► **Spare part management**

Immediate availability / delivery of original precision spare parts
Comprehensive inventory of spare parts / High availability
Spare parts express shipment as needed



► **Global service**

Service technicians visit you on site



► **Service Hotline**

Skilled service representatives answer your questions and provide additional support in the event of a problem
Contact information: www.benz-tools.com

ANGLE HEADS

ORDER INFORMATION

INQUIRY FORM

Please find our electronically editable inquiry form in the download area on our website.



Scan the QR Code or visit our website for download:
▶ <https://www.benz-tools.de/de/service/downloads>



ONLINE PRODUCT CONFIGURATOR

Set up your perfect aggregate easily:
Simply choose your desired design and add more product features click by click.



Scan the QR Code or visit our website for download:
▶ <https://www.benz-tools.de/en/products/metal/tooling-technology-machining-centers/angle-heads>



ONLINE PRODUCT CONFIGURATOR - CONFIGURATION EXAMPLE

▶ Selection - Design

▶ Selection - Angle head body

▶ Selection - Coolant supply

▶ Selection - Output spindle

▶ Selection - Size of output spindle

▶ Selection - Drive cone

▶ Selection - Size of drive cone

▶ Quote request

The screenshot displays the BENZ online product configurator for the 'ANGEL HEAD FORTE WWX'. The interface is organized into several sections:

- Navigation and Product Info:** Includes the BENZ logo, navigation tabs (HOME, PRODUCTS, SERVICE, SUPPORT, ABOUT), and a search bar. The product title 'ANGEL HEAD FORTE WWX' and a brief description are at the top right.
- Design Selection:** A sidebar on the left lists design options such as 'Tooling technology', 'High speed spindles', and 'Spindle cooling'.
- Angle Head Body Selection:** A section titled 'PLEASE CHOOSE THE SIDE OF THE ANGLE HEAD BODY' features a grid of 12 options with columns for 'Body' and 'Max. RPM'.
- Coolant Supply Selection:** A section titled 'PLEASE CHOOSE THE COOLING' offers options like 'No cooling', 'External CDS', and 'Internal CDS'.
- Output Spindle Selection:** A section titled 'PLEASE CHOOSE THE OUTPUT SPINDLE' shows four different spindle options.
- Size of Output Spindle Selection:** A section titled 'PLEASE CHOOSE THE SIZE OF THE OUTPUT SPINDLE' provides a grid for selecting spindle sizes.
- Drive Cone Selection:** A section titled 'PLEASE CHOOSE THE DRIVE CONE' displays six different drive cone options.
- Size of Drive Cone Selection:** A section titled 'PLEASE CHOOSE THE SIZE OF THE DRIVE CONE' offers a grid for selecting drive cone sizes.
- Final Configuration and Quote Request:** A 'Final product' section shows a 3D model of the configured tool and a 'Request quote' button.

USAGE NOTE

GENERAL

The contents of this catalog are not legally binding and are intended solely for informational purposes. Any final agreement will be in the form of a written order confirmation from BENZ GmbH Werkzeugsysteme, which occurs only subject to the respective current General Terms and Conditions of Sale and Delivery of BENZ GmbH Werkzeugsysteme. These can be found online at www.benz-tools.de.

All of the products listed in this catalog are designed for their intended use, e.g. machines for precision machining. The recognized technical regulations for safety and professional work must be followed for use and installation.

Furthermore, the respective laws, guidelines from TÜV, guidelines from the respective trade association and VDE stipulations shall apply.

The technical data listed in this catalog must be observed by the user. The conditions of use may not fall below or exceed the specified data. If information is missing, it cannot be assumed that there are no upper or lower limits or no limitations for specific use cases. Consultation is required in these cases.

Disposal is not included in the price, which would have to be taken into account accordingly in the event of return to or disposal by BENZ GmbH Werkzeugsysteme.

TECHNICAL DATA AND FIGURES

The technical data and figures have been compiled with great care and to the best of our knowledge. We cannot guarantee that the information is up to date, correct or complete.

The specifications and information—such as figures, drawings, descriptions, dimensions, weights, materials, technical and other performance data and the described products and services—contained in general product descriptions, BENZ GmbH Werkzeugsysteme catalogs, brochures and price lists in any form are subject to change and may be modified or updated at any time without prior notification. They are binding only to the extent expressly specified in a contract or order confirmation. Slight deviations from such descriptive product information shall be considered approved and shall not affect fulfillment of agreements insofar as they are reasonable for the customer.

LIABILITY

Products from BENZ GmbH Werkzeugsysteme are subject to the German Product Liability Act. This catalog does not contain any guarantees, assurances of quality or procurement agreements for the products it depicts, neither expressly nor implied, including for the availability of products. Advertising statements relating to quality features, properties or applications for the products are not legally binding.

To the extent permitted by law, BENZ GmbH Werkzeugsysteme is exempt from any liability for direct or indirect damage, subsequent damage and requests of any kind or on any legal basis resulting from the use of information contained in this catalog.

TRADEMARK, COPYRIGHT AND REPRODUCTION

The depiction of commercial property rights in this catalog—such as brands, logos, registered trademarks or patents—does not include the granting of licenses or use rights. Their use is not permitted without the expressed written agreement of BENZ GmbH Werkzeugsysteme. All contents of this catalog are the intellectual property of BENZ GmbH Werkzeugsysteme. For the purposes of copyright, any unlawful use of intellectual property, including excerpts, is prohibited. Reprinting, copying or translating (including in the form of excerpts) are permitted only with the prior written consent of BENZ GmbH Werkzeugsysteme.

STANDARDS

BENZ GmbH Werkzeugsysteme has a quality management system certified in accordance with ISO 9001:2008. BENZ GmbH Werkzeugsysteme has an environmental management system certified in accordance with ISO 14001:2004.

USAGE NOTE

INDIVIDUAL

DECLARATION OF INCORPORATION IN TERMS OF THE EC DIRECTIVE 2006/42/EC ON MACHINERY (ANNEX II 1 B)

We hereby declare that our products meet the basic requirements of the Machinery Directive 2006/42/EC as an incomplete machine to the extent that this is possible as part of delivery.

We also declare that the specific technical documents were produced in accordance with Annex VII Part B of this Directive. We undertake to provide the market supervisory bodies with versions of the incomplete machine's special documents via our documentation department should they have reason to request them.

The incomplete machine also satisfies the stipulations of EC Directive 2014/30/EC on electromagnetic compatibility. The protective goals of EC Directive 2014/35/EC regarding electronic equipment have been met.

The incomplete machine may only be commissioned if it has been ascertained, if applicable, that the machine or system in which the incomplete machine is to be installed satisfies the requirements of Directive 2006/42/EC on Machinery and an EC declaration of conformity has been drawn up in accordance with Annex II.

ARE YOU ALREADY FAMILIAR WITH OUR EXPERTISE? GET TO KNOW US!

- ▶ **TEAMS OF EXPERTS WITH INDUSTRY EXPERIENCE**
- ▶ **LARGE INTERNATIONAL NETWORK THROUGH WORLD-WIDE LOCATIONS AND PARTNERS**
- ▶ **THE HIGHEST QUALITY FOR ALL PRODUCTS AND SERVICES**
- ▶ **PRECISE, CUSTOMER-SPECIFIC SOLUTIONS**
- ▶ **CONSTANT DEVELOPMENT OF OUR INDUSTRY EXPERTISE**

The contents and data correspond to the status as of printing. Edition 03/2018

This catalog was created with great care and all information has been checked for accuracy. However, we assume no liability for incorrect or incomplete information.

Benz GmbH Werkzeugsysteme reserves the right to technical changes and improvements through constant ongoing development of products and services. All text, images, depictions and illustrations in this catalog are the property of Benz GmbH Werkzeugsysteme* and protected by copyright. Any duplicating, editing, changing, translating, filming, processing or saving in electronic systems is prohibited without the consent of Benz GmbH Werkzeugsysteme.

BENZ GmbH Werkzeugsysteme

Im Mühlegrün 12

D-77716 Haslach

T +49 7832 704-0

F +49 7832 704-8001

info@benz-tools.de

www.benz-tools.de

