

MiCROCUT



CNC SLANT BED LATHE

52/76/92 HT/HTL Series
52/76/92 HTY/HTLY Series



National Award
of Outstanding



ISO 9001:2015
FM 538421



ISO 14001:2015
EMS 546518



ISO 50001:2011
ENMS 642457

CNC Slant-Bed Lathe

HT/HTL Series

HTY/HTLY Series

MICROCUT HT/HTL series and HTY/HTLY series slant bed lathes offer large swing capacity with maximum cutting diameter 450mm and cutting length 1,250mm. The one-piece 45° slant casting bed ensures the rigidity of machine structure for heavy loading. Numerous optional accessories are selectable to meet the demands of various industries, including automotive, medical, educational, and general machining shops.



Highlights

- Wide selections of spindle bar capacity 51mm, 76mm and 90mm
- Heavy workpiece loading
- Optimized headstock design for easy heat dissipation
- One-piece rigid design with 45° slant bed
- Hydraulic oil pressure detection device and anti-oil-leakage monitoring system
- 8 or 12 positions hydraulic turret with fast indexing
- Tailstock rapid positioning driven by saddle
- Programmable tailstock and quill movement
- Large and concise machining room ensures easy chip cleaning
- Fully CNC package including controls and motors
- CE declaration of conformity for EU countries
- Automatic door with anti-tripping detecting system provides safety working environment.



One-piece 45° slant bed

Rigid & Space-Saving Structure

- All box-way structure is designed for great rigidity and heavy-duty cutting.
- One-piece 45° slant bed is integrated with guideways of the saddle and tailstock to ensure the efficient chip disposal, floor space saving, and elimination of thermal distortion.
- Each guideway is induction hardened and precision grounded.
- The rigid main structure of fine grain Meehanite certified cast iron prevents the machine deformation during heavy duty cutting.

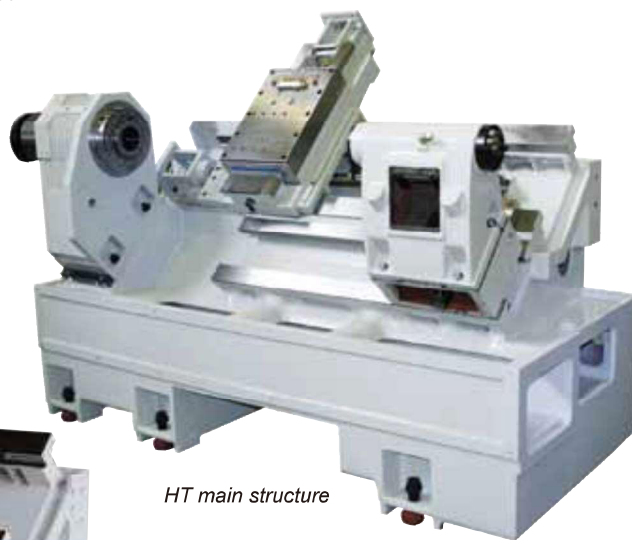

HT main structure

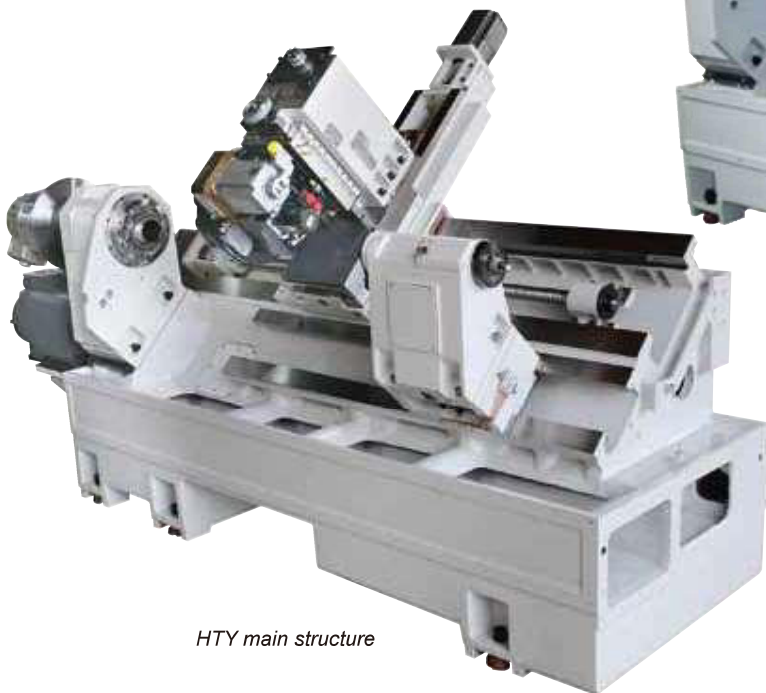

HTY main structure

Robust Design

Headstock & Spindle

Headstock Cross Section

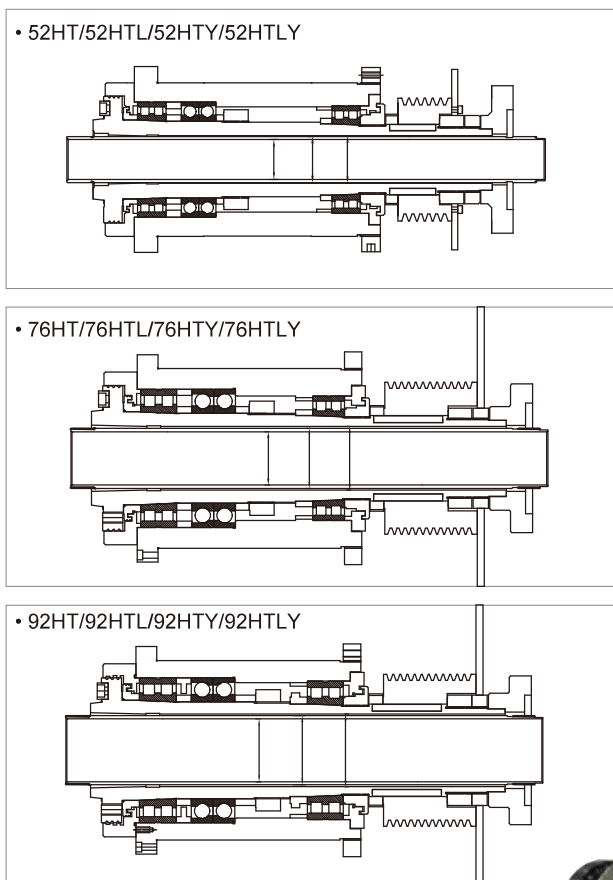

Headstock & Spindle Structure

- The spindle bearing with grease lubrication ensures the long service time.
- Heavy duty cartridge type spindle is supported by large dia. double row of cylindrical (NN) roller bearings at front and rear.
- The front NN roller bearing is at the fixed end and the rear one is at the floating end. When the spindle expands due to the thermal growth, it will extend backwards to the rear to eliminate the thermal deformation.
- The Meehinite casting headstock with rib shape surface design can expand the area for better heat dissipation.

- 1 The heavy duty cartridge type spindle is supported by double-row cylinder roller bearings.
- 2 Rib shape surface design for easy heat dissipation
- 3 One-piece 45° slant bed design ensures rigidity for heavy duty cutting and floor space-saving as well as easy chip falling and removing.
- 4 Rigid box-way structure is favorable for heavy duty cutting.

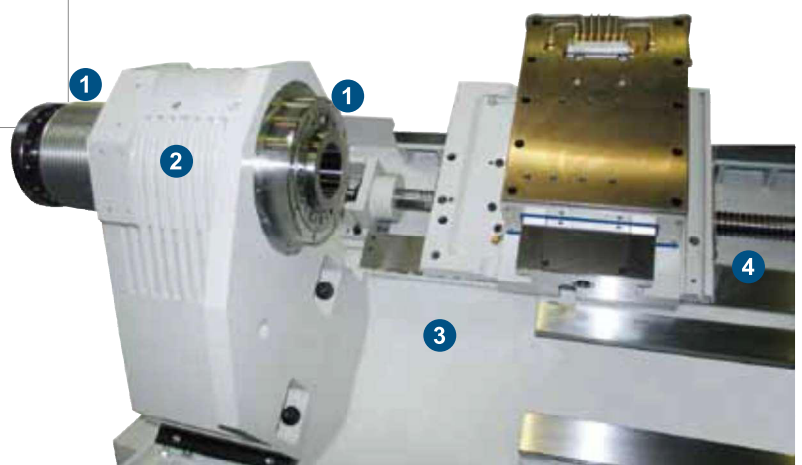



Model 92HTY

Axis Drive & Ballscrew



Axis Drive

Axis Drive & Ballscrew

Each axis is powered by digital AC servo motor. Driven by the high torque motor, the ballscrew performs in quiet and responsive slide movement with no backlash.

Tailstock

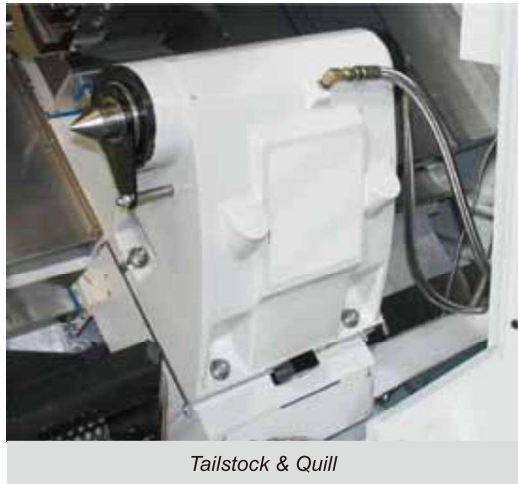

Tailstock & Quill

Axis Drive & Ballscrew

- The tailstock is positioned by a drive bar engaging with the carriage, and programmable drive bar for clamping/unclamping.
- The quill can be programmed and activated by foot pedal.
- The guideway of the tailstock is integrated with the one-piece bed to make the stronger tailstock movement.

Mill-Turn Capability

HT/HTL series and HTY/HTLY series feature an integrated Y axis & C axis to perform highly complex machining, and hence bring better performance and productivity from versatile applications.



Y-Axis versatility

The Y-axis provides perpendicular motion to the X-axis which enables diverse and off-center machining for complicated parts. With the additional Y axis, to turn and mill complex parts and perform multiple operations on a single machine is easy and convenient.

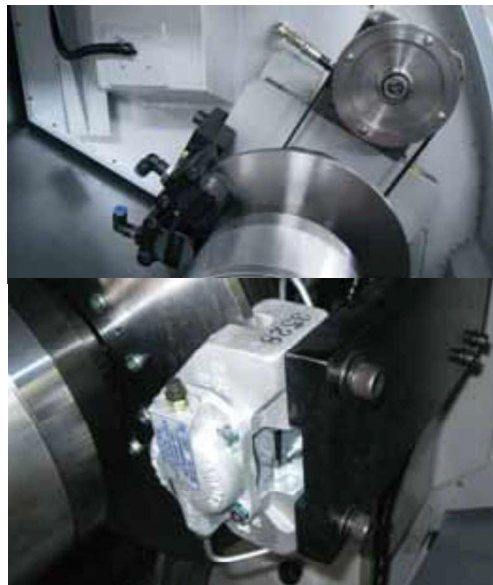

C-Axis

The C axis with hydraulic braking system provides superior machining performance, enabling turning, milling and drilling features to be ordered together in a single setup.

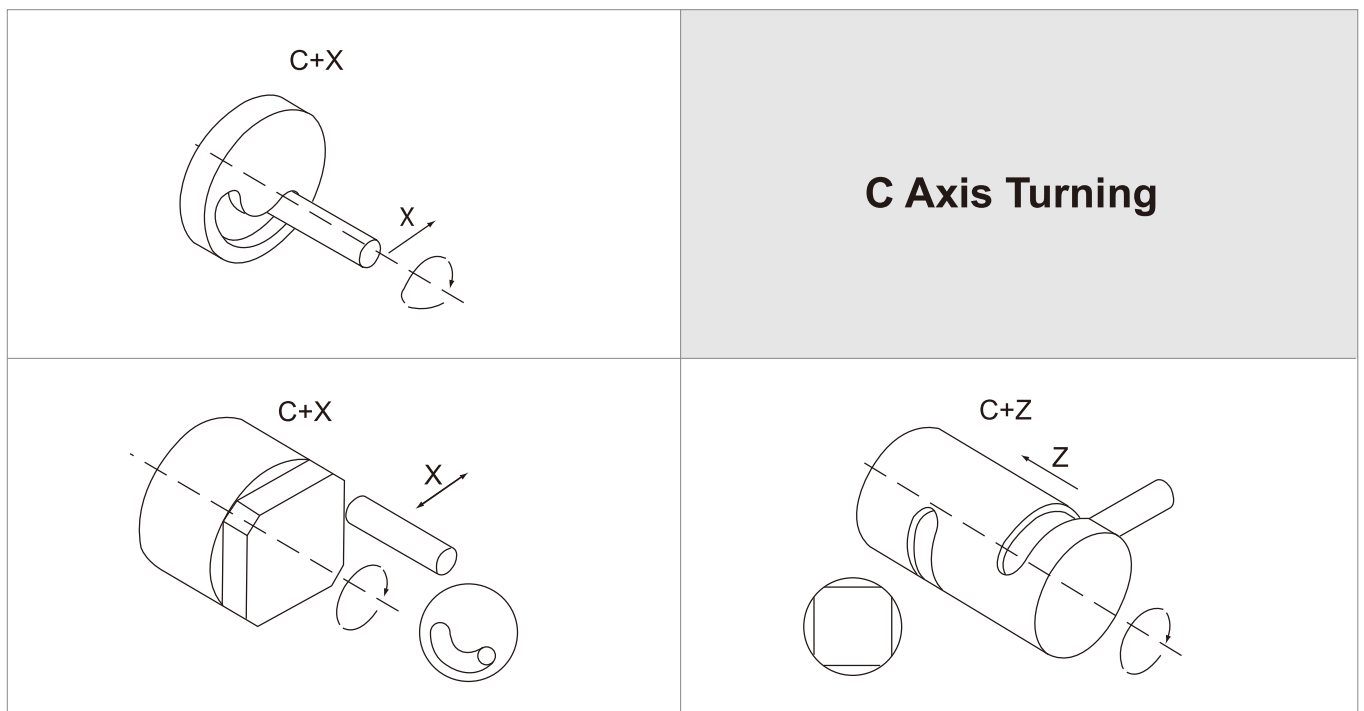

Turret

Fast Turret Index

The hydraulic turret with mechanical cam and the turret index is non-stop and bi-directional, and turret rotation is driven by high torque output with stable movement, which features high indexing accuracy and fast tool change.

HT/HTL



Hydraulic Type Turret w/ Standard Disc



Hydraulic Type Turret w/ VDI Disc (Opt.)

HTY/HTLY

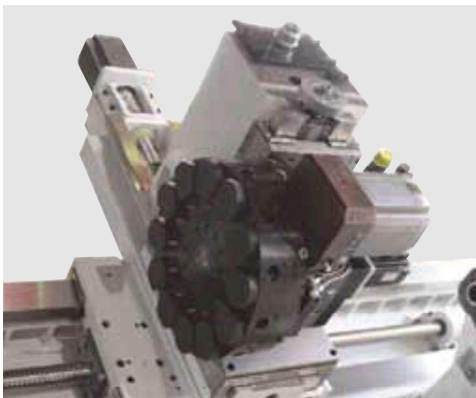

Hydraulic Type Turret VDI Disc

Power Turret Capacity

Twist Drilling	Tapping	Slot milling
$d \times a$ (mm x mm) 20 x 0.20	$d \times p$ (mm x mm) M16 x 2	$d \times p \times a$ (mm x mm x mm/min) 25 x 14 x 40

Production Maximization

Bar Feeder / Parts Catcher / Parts Catcher Box (Opt.)

The HT Series can be outfitted with bar feeder/automatic parts catcher/parts catcher box to maximize the productivity and to save time.

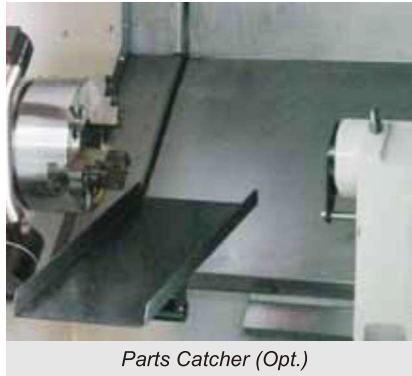

Hydraulic Chuck Fitting

For automatic production, HT Series is equipped with 8" hydraulic chuck as standard, and the sizes of 10", 12" and 15" are available on request.

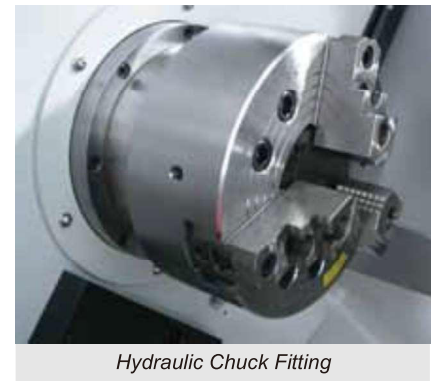

Manual / Auto. Tool Setter (Opt.) & Cut-Off Detector (Opt.)

The optional cut-off detector and Renishaw tool probe can reduce set-up time.

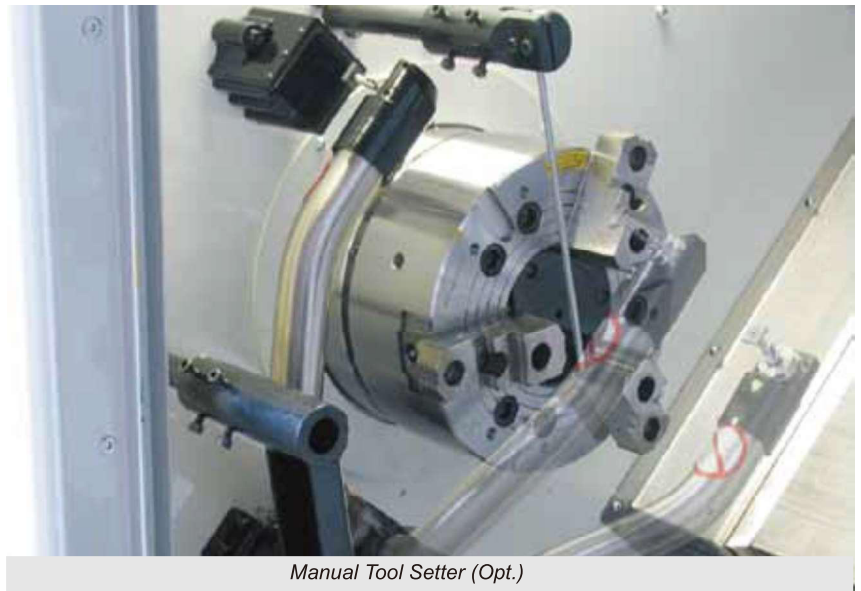

Safety Design

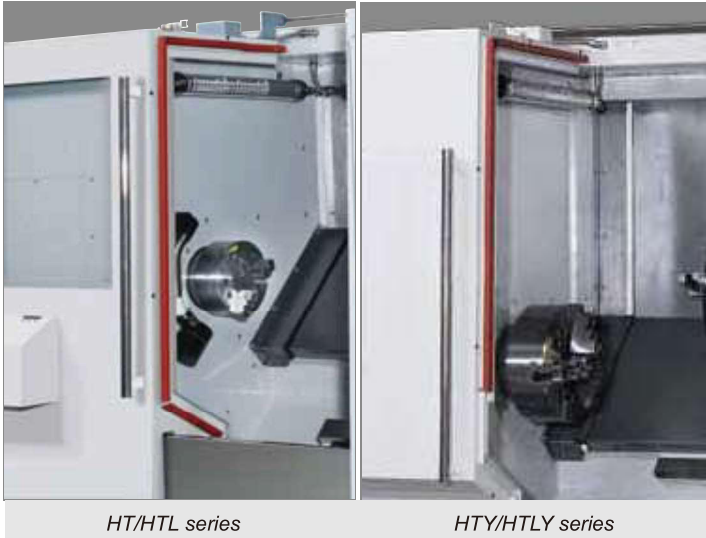

HT/HTL series

HTY/HTLY series

Automatic Door with Safety System

The anti-trapping detecting strip is installed on the top and upper lateral of the auto door. When a foreign object is trapped by or collided with the auto door, the electric contact points placed on the detecting strip are activated, and immediately send the signal to the PLC to stop the door closing. The door moves backward quickly to avoid trapping the foreign object and injuring the operator.

Front Door Interlock

The CE certified safety proximity switch is installed at the front door, which can ensure the automatic operation is activated only when the door closed to secure the safety working environment.



CE-Marked Electric Cabinet

CE Declaration of Conformity for EU Countries

All MICROCUT machines are made to meet the EU consumer safety, health, and environmental requirements and comply with CE Marking Declaration of Conformity for EU countries.

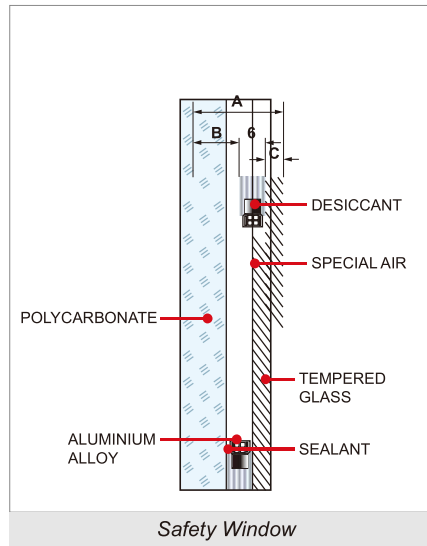

Safety Window

Safety Window

The 2-layer window is made of Polycarbonate and safety glass which complies with all the safety regulations.

Standard Accessories

- The availability of CNC controllers:
 - Fagor 8055i/FL
 - Fanuc Oi with Manual Guide Oi
 - Siemens 828D BASIC
- 8-position hydraulic turret, regular type
- Hydraulic 3-jaw chuck w/ hard jaws
- High pressure coolant system
- Auto lubrication system
- Work lamp
- Hydraulic unit
- Programmable tailstock
- Fully enclosed splash guard w/ interlock safety device
- Auto lock/unlock door
- CE marking declaration of conformity
- Heat exchanger integrated with electric cabinet



1 Hydraulic Unit

The chuck, turret (LS type) and tailstock are driven by the hydraulic power. A sensor on the hydraulic tank can detect the hydraulic pressure. The alarm will be triggered when the pressure is under 10kg/cm^2 .

2 Auto. Lubrication system

Automatic lubrication system is provided to all guideways and ballscrews. The distributor delivers a precise quantity of oil to each lubrication point. A low level alarm will trigger when lubrication is under the standard level to prevent the failure of oil distribution.

Optional Accessories

- Soft jaw for 8"/10"/12" chuck
- Tool holder package for standard (regular) turret
- Bigger hydraulic chuck
- Collet unit
- Various sizes of collets
- C axis
- Power turret
- Live tool holders
- Auto parts catcher w/ parts catcher box
- Renishaw tool setter
- Bar feeder and bar feeder interface
- EMC
- Oil skimmer
- 20 bar coolant through spindle

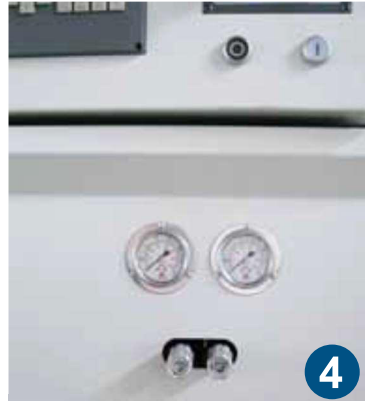
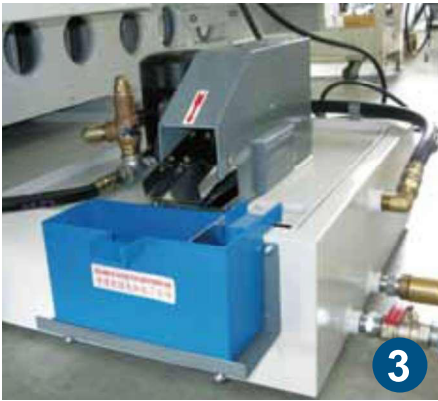

3 Oil Skimmer (Opt.)

The oil skimmer easily skims off the waste oil to prolong the life of machine coolant.

5 Integrated Heat Exchanger

The heat exchanger is integrated within the electric cabinet, making efficient heat dissipation and saving the floor space.

4 Hydraulic Pressure Switch

The hydraulic pressure could be adjusted by the switches under the control panel (photo shown the hydraulic gauge and hydraulic pressure switch).

Tooling System DTD. TURRET

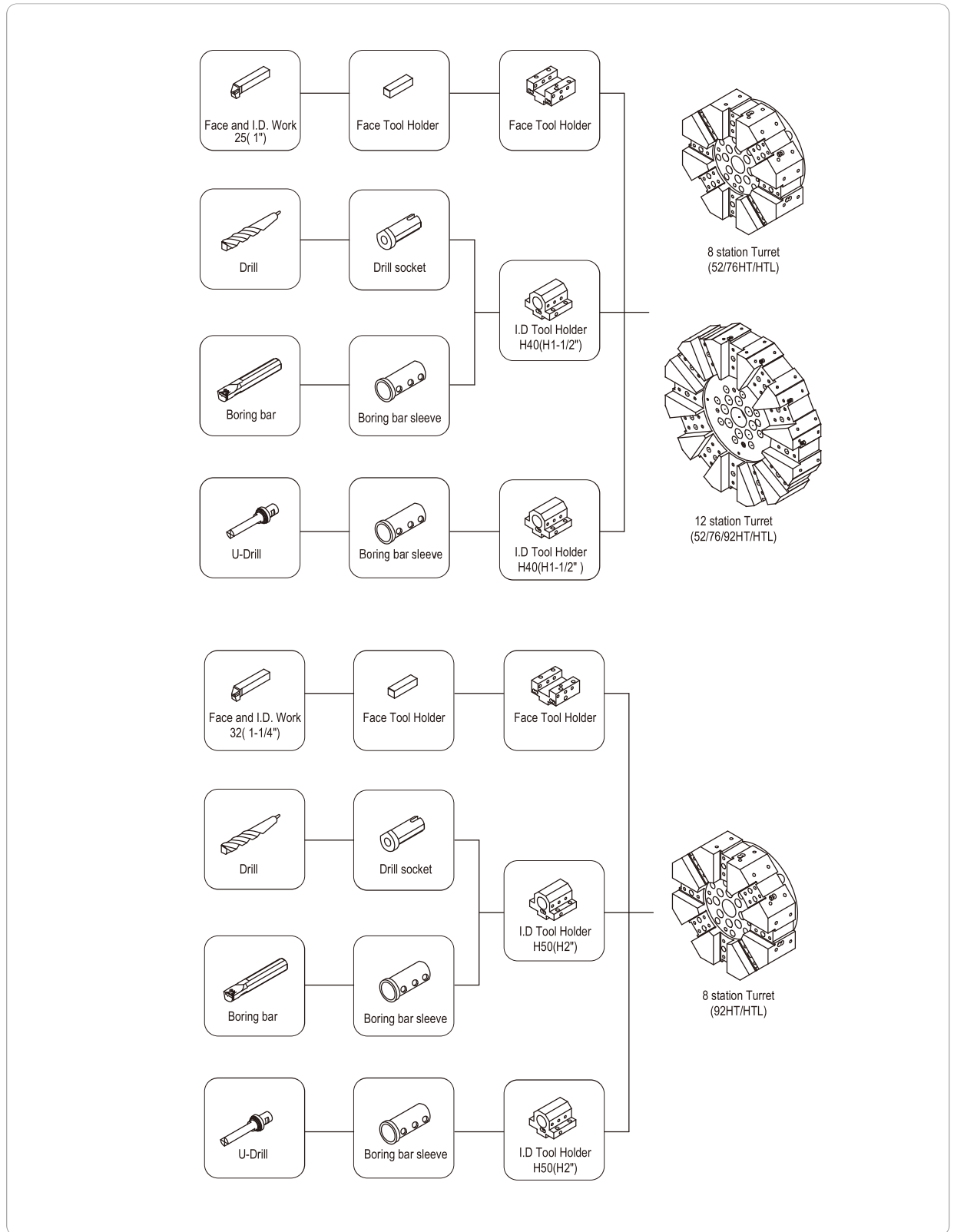

Tooling System VDI TURRET

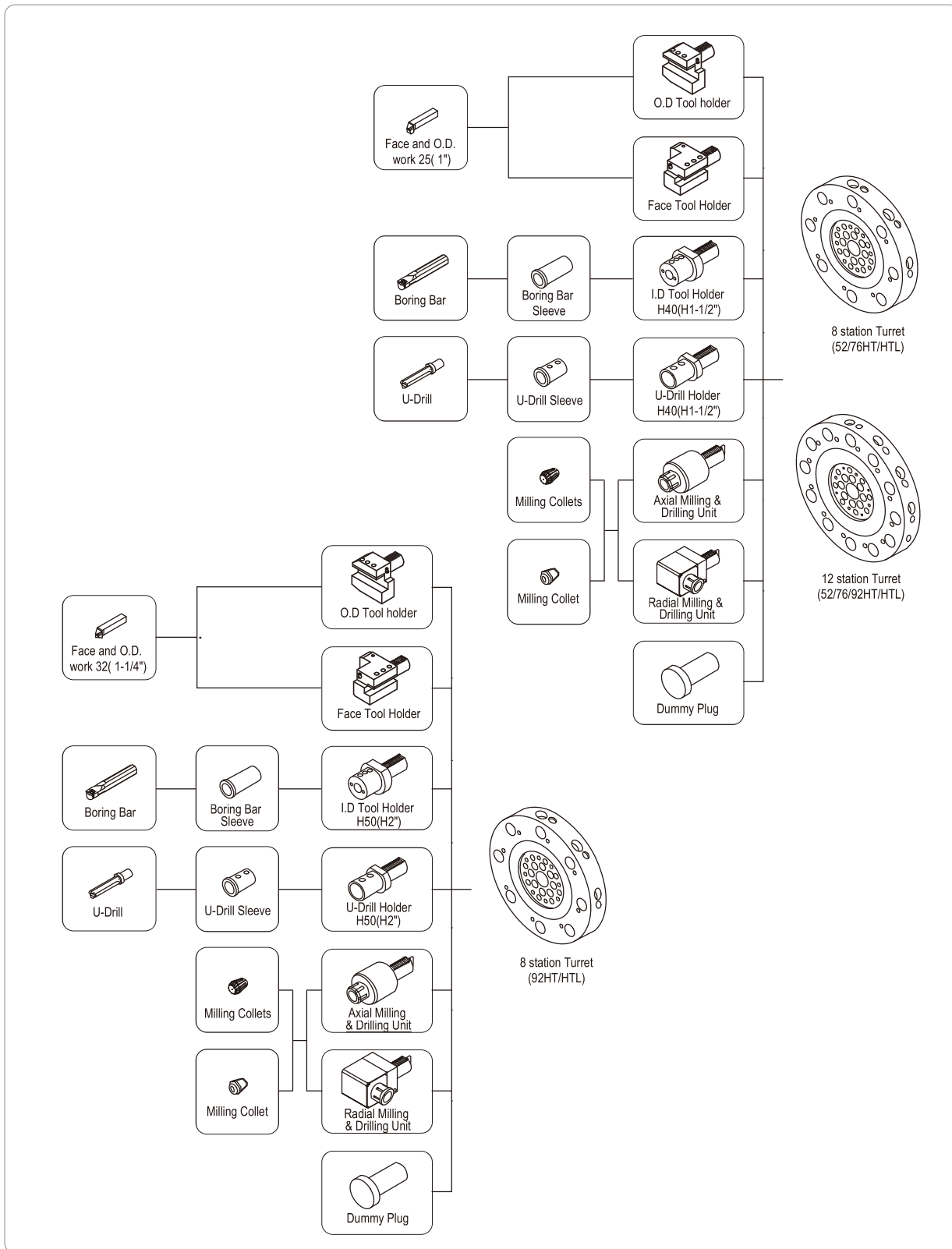

Power & Torque Chart

52HT/52HTL/52HTY/52HTLY

Std: 11/15kW

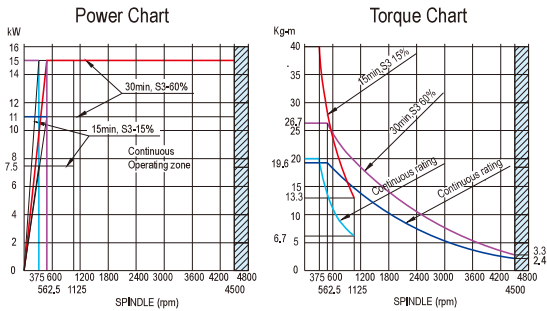

Power / Torque Chart Data			
Spindle Taper	ISO	A2-8	Spindle Motor
		-	FANUC αP22/6000i
		-	Motor Output
		-	11/15kW
		-	Gear Ratio
		-	-
Spindle Speed	4500 RPM		Pulley Ratio
			3/4

Opt: 15/18kW

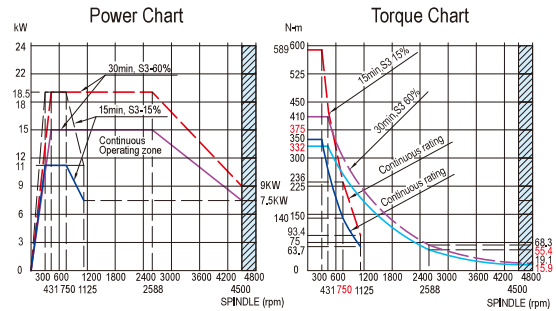

Power / Torque Chart Data			
Spindle Taper	ISO	A2-8	Spindle Motor
		-	FANUC αP30/6000i
		-	Motor Output
		-	15/18.5kW
		-	Gear Ratio
		-	-
Spindle Speed	4500 RPM		Pulley Ratio
			3/4

76HT/76HTL/76HTY/76HTLY

Std: 15/18.5kW

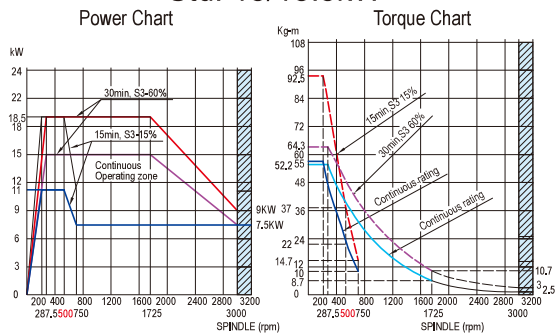

Power / Torque Chart Data			
Spindle Taper	ISO	A2-8	Spindle Motor
		-	FANUC αP30/6000i
		-	Motor Output
		-	15/18.5kW
		-	Gear Ratio
		-	1/2
Spindle Speed	3000 RPM		

Opt: 18.5/22kW

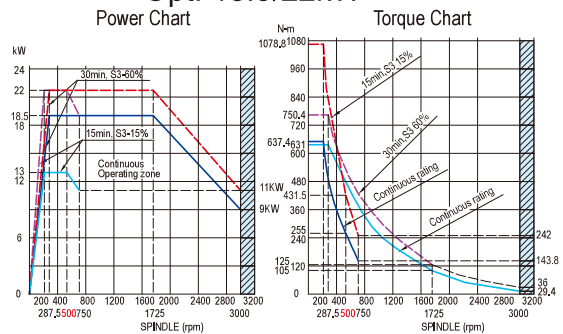

Power / Torque Chart Data			
Spindle Taper	ISO	A2-8	Spindle Motor
		-	FANUC αP40/6000i
		-	Motor Output
		-	18.5/22kW
		-	Gear Ratio
		-	1/2
Spindle Speed	3000 RPM		

92HT/92HTL/92HTY/92HTLY

Std: 18.5/22kW

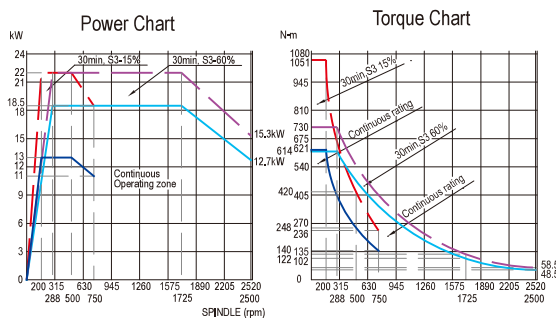

Torque / Power Chart Data			
Spindle Taper	ISO	A2-8	Spindle Motor
		-	FANUC αP40/6000i
		-	Motor Output
		-	18.5/22kW
		-	Gear Ratio
		-	1/2
Spindle Speed	2500 RPM		

Opt: 22/30kW

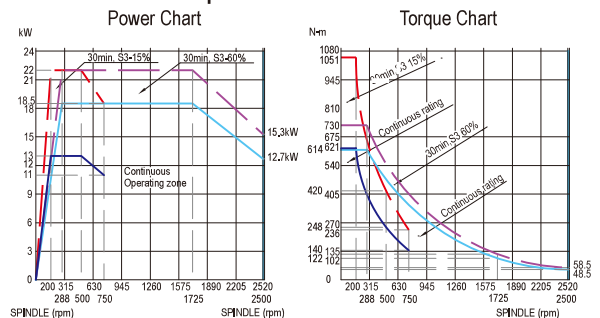

Torque / Power Chart Data			
Spindle Taper	ISO	A2-8	Spindle Motor
		-	FANUC αP50/6000i
		-	Motor Output
		-	22/30kW
		-	Gear Ratio
		-	1/2
Spindle Speed	2500 RPM		

Layout

HT series

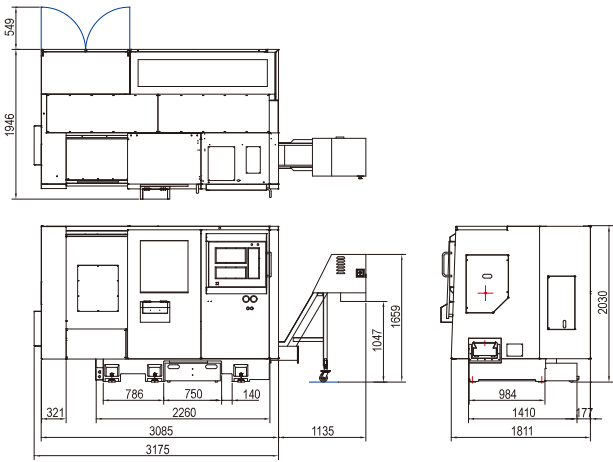

HTL series

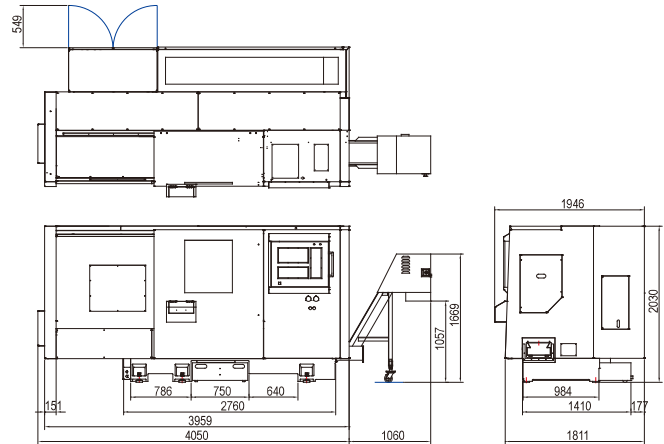

HTY series

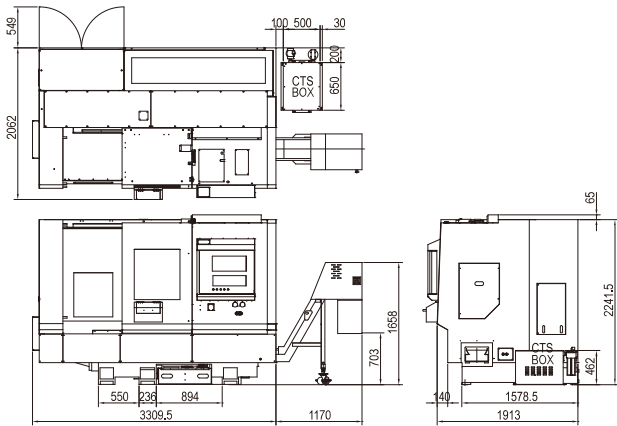

HTLY series

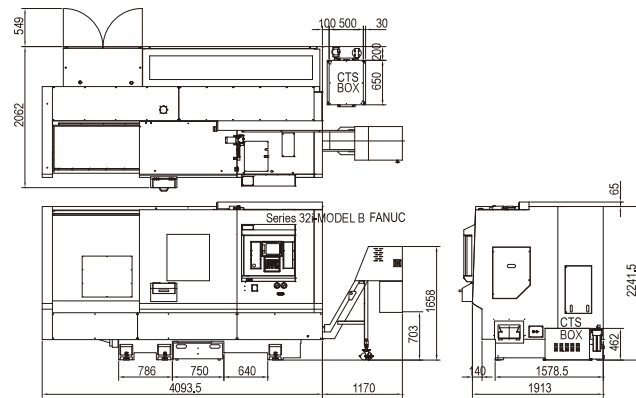

Technical Data

Item	Description	Unit	52HT/HTL	52HTY/HTLY	76HT/HTL	76HTY/HTLY	92HT/HTL	92HTY/HTLY
Capacity	Swing over bed	mm	600	700	600	700	600	700
	Swing over cross slide	mm	450	460	450	460	450	460
	Max. turning dia. (w/ turret)	mm	580	400/385	580	400/385	580	400/385
	Max. turning length (w/ turret)	mm	750/1250	750/1250	750/1250	750/1250	750/1250	750/1250
	Bar capacity	mm	51(A2-6)	51(A2-6)	76(A2-8)	76(A2-8)	90(A2-8)	90(A2-8)
Spindle	Spindle nose		A2-6	A2-6	A2-8	A2-8	A2-8	A2-8
	Through hole diameter	mm	66	66	92	92	105	105
	Spindle front bearing inner dia.	mm	100	100	130	130	140	140
	Chuck size	mm	200(8")	200(8")	250(10")	250(10")	305(12")	305(12")
	Spindle speed	rpm	4,500	4500	3000	3000	2500	2500
	Spindle output	kW	12/18.5 (Fagor); 11/15 (Fanuc); 17/22.5 (Siemens)	12/18.5 (Fagor) 11/15 (Fanuc) 17/25.5 (Siemens)	17/25 (Fagor); 15/18.5 (Fanuc); 30/45 (Siemens)	17/25 (Fagor); 15/18.5 (Fanuc); 30/45 (Siemens)	22/33 (Fagor); 18.5/22 (Fanuc); 28/42 (Siemens)	22/33 (Fagor); 18.5/22 (Fanuc); 28/42 (Siemens)
	Hydraulic pressure	Kgf/cm ²	40	50	40	50	40	50
Travel	X	mm	305	245 (Radial turret)/ 275 (Axial turret)	305	245 (Radial turret)/ 275 (Axial turret)	305	245 (Radial turret)/ 275 (Axial turret)
	Y	mm	-	110±55	-	110±55	-	110±55
	Z	mm	750/1250	750/1250	750/1250	750/1250	750/1250	750/1250
Turret	Turret type		Hydraulic	Hydraulic	Hydraulic	Hydraulic	Hydraulic	Hydraulic
	Tool number	T	8/12	12	8/12	12	8	12
	Boring bar dia.	mm	Ø40	Ø32 (Radial turret)/ Ø40 (Axial turret)	Ø40	Ø32 (Radial turret)/ Ø40 (Axial turret)	Ø50	Ø32 (Radial turret)/ Ø40 (Axial turret)
Live Tooling (option)	Tool allowance (square)	mm	25x25	25x25	25x25	25x25	32x32	25x25
	Tool shank	mm	VDI40	BMT55/VDI40	VDI40	BMT55/VDI40	VDI50	BMT55/VDI40
	Power rating	kW	3.7	3.7	3.7	3.7	3.7	3.7
	Max. speed	rpm	4,000	4000	4000	4000	4,000	4000
Tailstock	Tailstock travel	mm	600	600	600	600	600	600
	Quill travel	mm	120	120	120	120	120	120
	Quill diameter	mm	90	90	90	90	90	90
	Quill inside taper	MT	5	5	5	5	5	5
Axes	X axis ballscrew		Ø36xP8xC3	Ø36xP12xC3	Ø36xP8xC3	Ø36xP12xC3	Ø36xP8xC3	Ø36xP12xC3
	X axis rapid feed	m/min	24	24	24	24	24	24
	Y axis ballscrew		-	Ø32xP5xC3	-	Ø32xP5xC3	-	Ø32xP5xC3
	Y axis rapid feed	m/min	-	7.5	-	7.5	-	7.5
	Z axis ballscrew		Ø50xP12xC3	Ø50xP12xC3	Ø50xP12xC3	Ø50xP12xC3	Ø50xP12xC3	Ø50xP12xC3
	Z axis rapid feed	m/min	24	24	24	24	24	24
	Jog feed per revolution	m/min	3	3	3	3	3	3
Accuracy	Positioning accuracy	mm	0.01/300	0.01/300	0.01/300	0.01/300	±0.01/300	0.01/300
	Repeatability accuracy	mm	±0.01	±0.01	±0.01	±0.01	±0.01	±0.01
Coolant	Pump motor	W	620(50Hz)/910(60Hz)					
	Max. pump flow	L/min	58(50Hz)/66(60Hz)					
	Max. pump pressure	Kgf/cm ²	10					
Hydraulic	Tank capacity	L	70					
Miscellaneous	Length (w/o chip conveyor)	mm	3175(HT)/ 4050(HTL)	3310(HTY)/ 4184(HTLY)	3175(HT)/ 4050(HTL)	3310(HTY)/ 4185(HTLY)	3175(HT)/ 4050(HTL)	3310(HTY)/ 4185(HTLY)
	Length (w/ chip conveyor)	mm	4310(HT)/ 5110(HTL)	4480(HTY)/ 5355(HTYL)	4310(HT)/ 5110(HTL)	4480(HTY)/ 5355(HTYL)	4310(HT)/ 5110(HTL)	4480(HTY)/ 5355(HTYL)
	Width	mm	1,811 (w/o parts catching box) / 1,946 (w/ parts catching box)					
	Height	mm	2030	2250	2030	2250	2030	2250
	Weight	kg	5400	7600(HTY) / 8600(HTLY)	5500(HT)/ 6500(HTL)	7600(HTY)/ 8600(HTLY)	5600(HT)/ 6600(HTL)	7600(HTY)/ 8600(HTLY)
	Total power consumption	KVA	Fagor:50	Fagor:50	Fagor:50	Fagor:50	Fagor:70	Fagor:70
			Fanuc:35	Fanuc:35	Fanuc:35	Fanuc:35	Fanuc:50	Fanuc:50
Siemens:35			Siemens:35	Siemens:35	Siemens:35	Siemens:35	Siemens:35	

*Specifications are subject to change without notice.

BUFFALO MACHINERY CO., LTD.

56, Lane 318, Desheng Road, Daya District,
Taichung City 428-46, Taiwan
P.O. Box 320, Daya, Taichung City, Taiwan
Tel: +886-4-25 60 37 59 Fax: +886-4-25 60 37 69
E-mail: info@mail.buffalo.com.tw
www.buffalo-machinery.com



MICROCUT EUROPE

Ulica hrvatskih branitelja 3
10430 Samobor CROATIA
Tel. +385 1 3141 515
Fax. +385 1 3141 516
info@microcut-europe.eu
www.microcut-europe.eu

